

cut along dotted line to remove torn outer cover

# **EWS SERIES ESS 1000X**



# EcoWater **SERIES ESS 1000X** Water System

**ECOWATER CUSTOMER . . .** Your EcoWater dealer has assembled, installed, and adjusted the water system to your household's specific needs. Just keep the brine tank filled with salt and the EcoWater System unit will provide you with a continuous supply of conditioned water. *Check the salt storage level every few weeks, and always refill the tank before all the salt is gone. Use cube, pellet, or other **clean** water softener salt. **Do not** use rock salts, or salt with iron removing additives. Iron removing additives release fumes that may corrode and shorten the life of some EcoWater System unit parts.*

Your dealer has set the timer to the correct time, and settings to provide you with continuous soft water. If electrical power to your house. . . or just to the softener. . . is interrupted, use the procedures on pages 5 and 6 to reset the timer.

**NOTE:** The timer has a 48 hour (or more) "POWER-OUTAGE MEMORY". When electrical power goes off, but is then restored within the 48 hours, the correct time shows and the softener will operate normally. When power is off longer, a time will *flash* in the display meaning you must set the correct time of day.

## DIMENSIONS

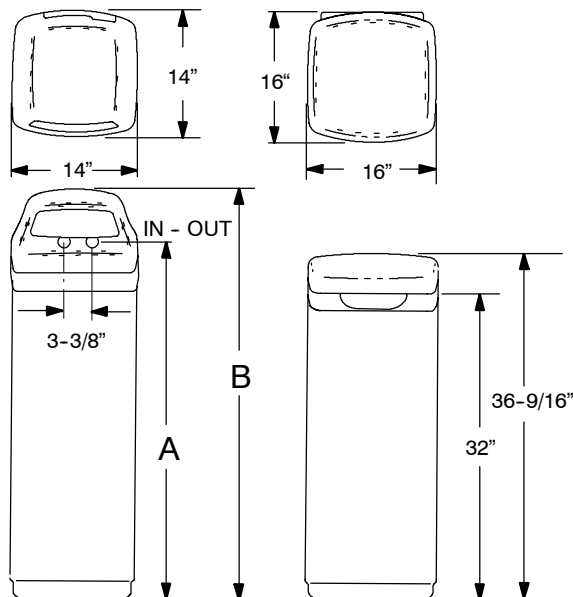

MODEL	NOMINAL RESIN TANK SIZE	A	B
<b>ESS 1000XR24</b>	8" DIA. X 40"	41.6"	48.75"
<b>ESS 1000XR32</b>	10" DIA. X 47"	49.8"	56.6"



Systems Tested and Certified by NSF International and WQA against NSF/ANSI Standard 44 for softener performance.

	ESS 1000XR24	ESS 1000XR32
Rated Service Flow Rate (gpm)	7.2	9.0
Pressure Drop at Rated Service Flow Rate (psi)	15	13
Intermittent Flow Rate @ 15 psi (gpg)**	7.2	9.6
Intermittent Flow Rate @ 30 psi (gpg)**	11.4	14.4
Rated Softening Capacity (Grains @ Salt Dose)	13,300 @ 2.6 lbs 22,400 @ 5.6 lbs 29,000 @ 8.6 lbs	13,400 @ 2.9 lbs 28,600 @ 9.2 lbs 34,400 @ 15.6 lbs
Amount of High Capacity Resin (cu ft)	.88	.98
Water Pressure Limits (min/max psi)*	20 - 125	
Min./Max. Water Temperature (°F)	40° - 120°	
Min. Water Supply Flow Rate (gpm)	3	
Max. Drain Flow Rate (gpm)	2.0	2.2

These systems, when containing EcoWater Systems resin part number 0502272 or 0501741 in the amount listed above, conform to NSF/ANSI 44 for the specific performance claims as verified and substantiated by test data.

\* Canada working pressure limits 1.4 - 7.0 kg/cm<sup>2</sup>

\*\* Intermittent flow rate does not represent the maximum service flow rate used to determine softeners rated capacity. Continuous operation at flow rates greater than the service flow may affect capacity and efficiency performance. The validation of these flow rates if verified by NSF.

EcoWater Systems LLC  
P. O. Box 64420, St. Paul, MN 55164-0420  
(651) 739-5330

7275444 (Rev. C 11/18/05)

**LIMITED WARRANTY**  
**EcoWater Systems LLC ADVANTAGE WARRANTY**  
**Series ESS 1000X Water System**

Congratulations! You have just purchased the highest quality water conditioning product on the market. To register your warranty, complete the enclosed Warranty Registration Card and mail it within 30 days of purchase.

**To whom is this warranty extended?**

EcoWater Systems LLC warrants its products to the original owner and guarantees that the products will be free from defects in materials and workmanship from the original date of installation.

**How does this warranty work?**

If, during the respective warranty period, a part proves, after inspection by EcoWater, to be defective, EcoWater will, at its sole option repair or replace that part at no charge, other than normal shipping, installation or service charges.

**What is covered by the warranty?**

EcoWater Systems LLC guarantees that,

for a period of TEN (10) years, the SALT TANK and the MINERAL TANK will not rust, corrode, leak, burst, or in any other manner fail to perform their proper functions and that,

for a period of ONE (1) year after installation, the VALVE BODY and ALL OTHER PARTS will be free of defects in materials and workmanship and will perform their proper functions.

**How do I obtain warranty service?**

Should you need service, your local, independent EcoWater Dealer is only a phone call away. PHONE: \_\_\_\_\_  
To obtain warranty service, notice must be given, within thirty (30) days of the discovery of the defect, to your local EcoWater Systems dealer.

**If I need a part replaced after the factory warranty expires, is the replacement part warranted?**

Yes, EcoWater Systems LLC warrants FACTORY REPAIRS as well as all REPLACEMENT PARTS for a period of 90 DAYS. This warranty does not include normal shipping, installation or service charges.

**General Provisions**

The above warranties are effective **provided** the water conditioner is operated at water pressures not exceeding 125 psi, and at water temperatures not exceeding 120°F; provided further that the water conditioner is not subject to abuse, misuse, alteration, neglect, freezing, accident or negligence; and provided further that the water conditioner is not damaged as the result of any unusual force of nature such as, but not limited to, flood, hurricane, tornado or earthquake. EcoWater Systems LLC, is excused if failure to perform its warranty obligations is the result of strikes, government regulation, materials shortages, or other circumstances beyond its control.

**There are no warranties on the water conditioner beyond those specifically described above. All implied warranties, including any implied warranty of merchantability or of fitness for a particular purpose, are disclaimed to the extent they might extend beyond the above periods. The sole obligation of EcoWater Systems LLC under these warranties is to replace or repair the component or part which proves to be defective within the specified time period, and EcoWater is not liable for consequential or incidental damages. No EcoWater dealer, agent, representative, or other person is authorized to extend or expand the warranties expressly described above.**

Some states do not allow limitations on how long an implied warranty lasts or exclusions or limitations of incidental or consequential damage, so the limitations and exclusions in this warranty may not apply to you. This warranty gives you specific legal rights, and you may have other rights which vary from state to state. This warranty applies to consumer-owned installations only.

## SAFETY GUIDES, INSTALLATION AND OPERATION REQUIREMENTS

Follow the installation instructions carefully. Failure to install the unit properly voids the warranty.

**CHECK LOCAL PLUMBING AND ELECTRICAL CODES. THE INSTALLATION MUST CONFORM TO THEM.** In Massachusetts, plumbing codes of Massachusetts shall be adhered to. Consult with your licensed plumber.

**USE ONLY LEAD-FREE SOLDER AND FLUX FOR ALL SWEAT-SOLDER CONNECTIONS, AS REQUIRED BY STATE AND FEDERAL CODES.**

**Use only lead-free solder and flux** for all sweat solder connections, as required by state and federal codes. Use care when handling the unit. Do not turn upside down, drop, or set on sharp protrusions.

Do not locate the unit where freezing temperatures occur. Do not attempt to treat water over 120°F. **Freezing, or hot water damage voids the warranty.**

Avoid installing in direct sunlight. Excessive sun heat may cause distortion or other damage to non-metallic parts.

The system requires a minimum water flow of 3 gallons per minute at the inlet. **MAXIMUM ALLOWABLE INLET WATER PRESSURE IS 125 PSI.** If daytime pressure is over 80 PSI, nighttime pressure may exceed the maximum. Use a pressure reducing valve if necessary. Adding a pressure reducing valve may reduce the flow.

**The unit works on 24 volt - 60 Hz electrical power only.** Be sure to use the included transformer and plug it into a nominal 120V, 60 cycle household outlet that is grounded and properly protected by an over current device such as a circuit breaker or fuse. If transformer is replaced, use only the authorized service Class II, 24 volt, 10 VA transformer.

This system is not intended to be used for treating water that is microbiologically unsafe or of unknown quality without adequate disinfection before or after the system.



European Directive 2002/96/EC requires all electrical and electronic equipment to be disposed of according to Waste Electrical and Electronic Equipment (WEEE) requirements. This directive or similar laws are in place nationally and can vary from region to region. Please refer to your state and local laws for proper disposal of this equipment.

### BRINE TANK ASSEMBLY

**NOTE:** On some models, the factory may complete steps 1 and 2 below.

1. Locate the brine well in position and secure with a screw and nut (from parts skin-pack).
2. Lower the brine valve into the brine well and install the brine well cover.
3. Insert the grommet into the hole in the tank side-wall. Then, push the hose adaptor elbow into the grommet.

**Do the remaining assembly during installation.**

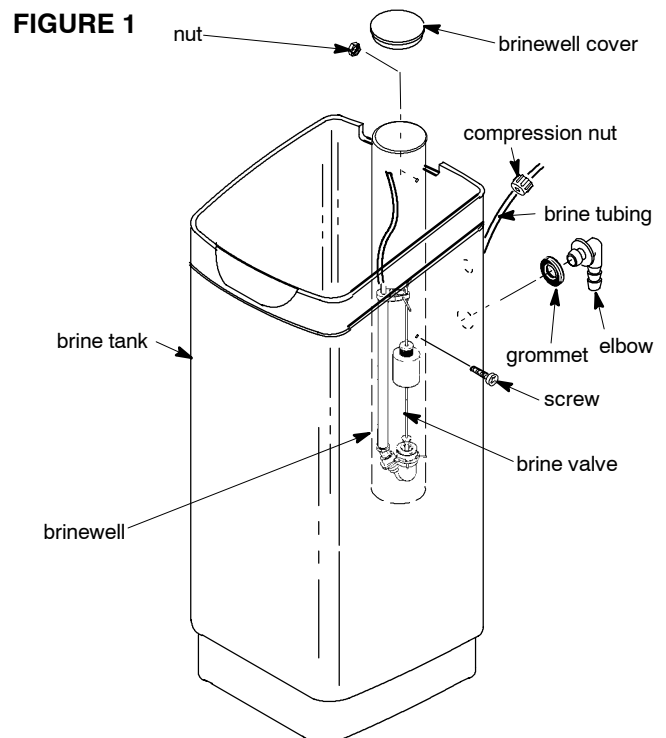

## INSTALLATION

BE SURE TO READ AND COMPLY WITH ALL GUIDES LISTED ON PAGE 3.

1. Install the installation adaptors, or the optional bypass valve (Figure 2). **Be sure clips hold parts firmly in place.** Pull on the adaptors or bypass valve to insure they are secure.

**NOTE:** If the optional bypass valve is not used, be sure to install a 3-valve bypass (Figure 3). Bypass valves allow you to turn off water to the softener for servicing, but still have water to the house pipes.

2. Run the **hard water** supply to the **valve inlet**,

and *conditioned water* out from the valve outlet

**NOTE:** Use the copper tubes, nuts and gaskets that are on the skin-pack. You can also plumb directly to the 1" NPT threads on the installation adaptors.

**CAUTION:** Do all soldering, and allow to cool, before connecting pipe to the adaptors or bypass valve.

3. Install the ground clamp kit if cold water pipe ground continuity was interrupted.

**FIGURE 2**

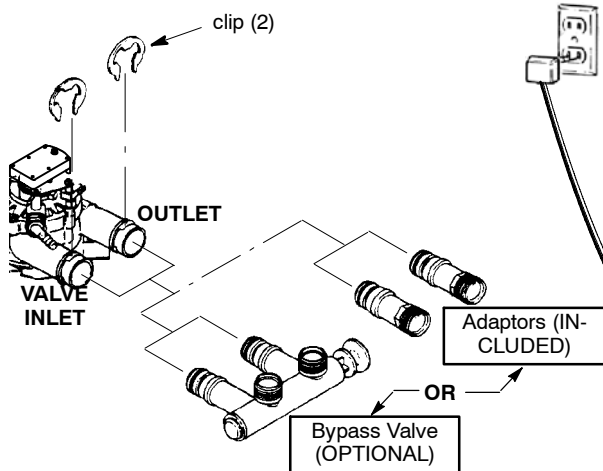

**FIGURE 3**

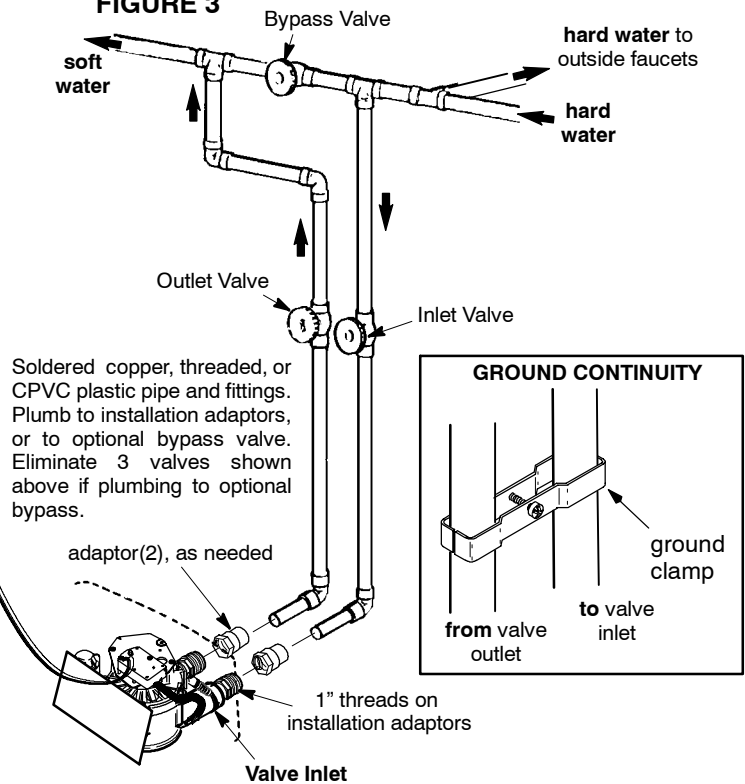

## INSTALLATION (continued)

- Run the valve and brine tank overflow drain hoses (Figure 4). Secure the valve drain hose to the drain fitting with the included hose clamp. Provide a minimum 1-1/2" air gap at the floor drain, standpipe, laundry tub, or other approved drain. If you need to elevate the valve drain hose to get to the drain point, do not raise more than 8' above the floor. The *gravity* overflow hose must be lower than the drain fitting along the entire run.

**NOTE:** Flexible drain hose is not allowed by some state or local codes. A fitting (1/4" NPT x 1/2" O.D. tube, part no. 0504574) is available from EcoWater for adapting copper tubing to the valve drain fitting.

- Route the brine valve tubing out of the brine tank and connect to the nozzle assembly. Use the small screen and compression nut included (on skin-pack) to fasten.
- Plug the transformer into a 120V - 60Hz electrical outlet.

**FIGURE 4**

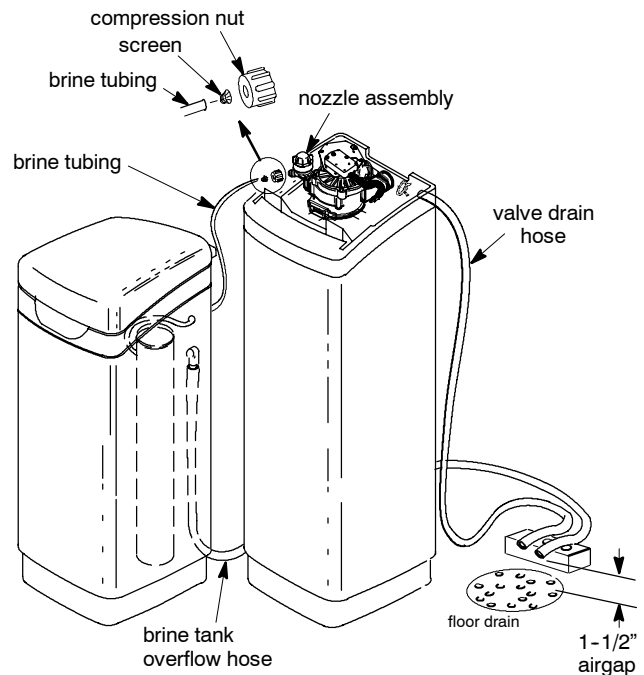

- Make all timer settings, pages 6 - 9.
- Open nearby faucets and advance (use RE-CHARGE keypad) the softener valve to back-wash position to vent air from the tank.** Turn on the water supply and allow the softener to fill. When water at nearby faucets runs smooth, with no more air bubbles, close the faucets and advance the softener valve to "service".
- Check your installation work for leaks.
- Sanitize the unit following procedures below, and use "Recharge Now" to start a recharge.
- Fill the brine tank with salt. You may use most water conditioner salts, but it must be clean. Recommended nugget, pellet or course solar salts have less than 1% impurities.
- Install the brine tank cover.

### WIRING SCHEMATIC

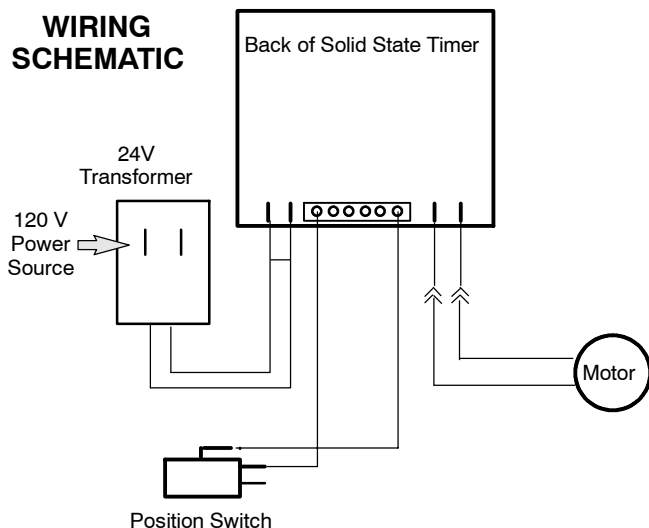

### DISINFECTING THE SOFTENER

Care is taken at the factory to keep your softener clean and sanitary. Materials used to make the unit will not infect or contaminate your water supply, and will not cause bacteria to form or grow. However, during shipping, storage, installing and operating, bacteria could get into the unit. For this reason, sanitizing as follows is suggested when installing.

- Use a pail or hose to fill the brine tank with about 3 gallons of water.
- Remove the brinewell cover and pour about 1-1/2 oz. (2 to 3 tablespoons) of common household bleach into the softener brinewell. Clorox, Linco, BoPeep, White Sail, Eagle, etc. are brand names of bleach readily available. **Replace the brinewell cover.**
- Start an automatic regeneration to draw the bleach into and through the softener, and to the drain. When regeneration is complete, all remaining bleach is flushed from the softener.

## SETTING THE TIMER

**FIGURE 5**

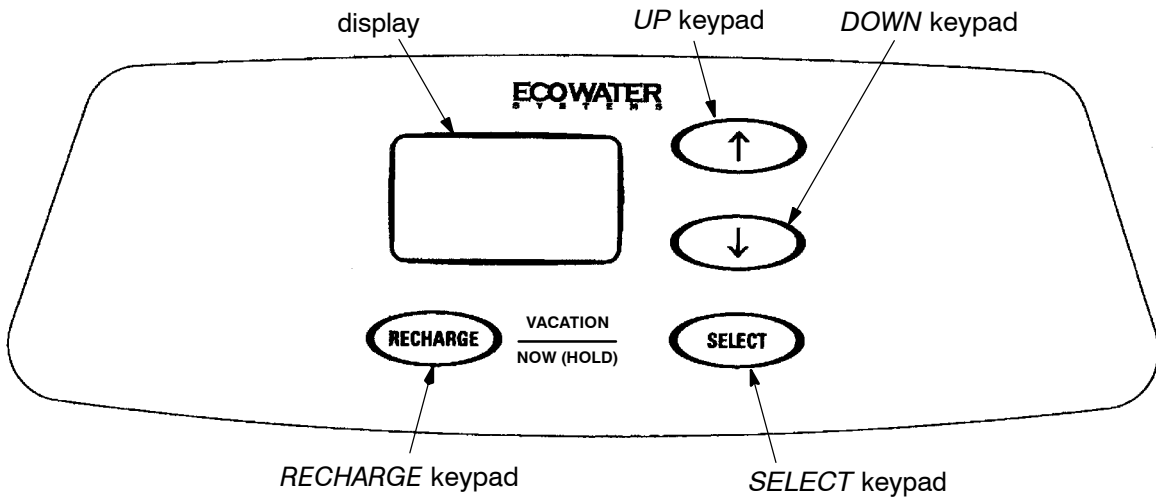

**TIMER SETTINGS REQUIRED**...upon installation, and after an extended power outage (see Power Outage Memory, page 1).

The PWA board is factory programmed for use as a tannin filter. If you are using the unit as a softener, follow the steps below to select the correct model code for your softener. If you are using the unit as a tannin filter, go to the set up steps on page 9. When the transformer is first plugged into the electrical outlet, the model code "StAn" is displayed for a few seconds,

followed by a test number (example J1.0).

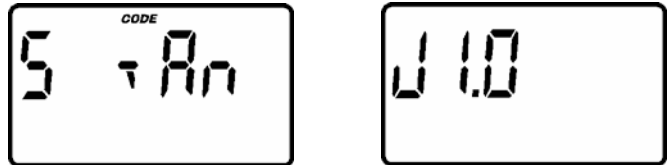

**NOTE:** When setting the timer, press the keypad repeatedly to advance the display slowly. Hold the keypad in for fast advance.

### ► **SET MODEL CODE (for softener use)** .....

**1.** Press and hold the SELECT keypad until (000--) shows in the display.



**2.** Press and hold the SELECT keypad once again until the model code appears in the display.



**3.** Press the UP or DOWN keypads to select the correct model code for softener use. See the chart below.

Model Code	Amount of resin	Tank Size
ST22	3/4 cu. ft.	8 x 40
ST27	.88 cu. ft.	8 x 40
ST31	1 cu. ft.	10 x 47
ST39	1-1/4 cu. ft.	10 x 47
S tAn	use for tannin filters	

**4.** Press the SELECT keypad to set the correct model code. Follow the steps on the next page to set the timer for use.

## SETTING THE TIMER (SOFTENERS)

### ► **SET PRESENT TIME** .....

1. Press the UP or DOWN keypads to set the present time of day. Be sure AM or PM, as applies, also shows.



2. Press the SELECT keypad to set the present time.

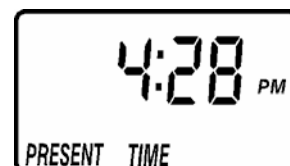

### ► **SET HARDNESS** .....

1. Press the UP or DOWN keypads to select your waters' hardness level. Default is 25.

2. Hardness level can be turned off by pressing the DOWN keypad below 1. This would be chosen if you wish to have the softener recharge at a specific number of days. If selected, the next set-up screen will be Set Days Between Recharge. If a hardness number is selected the next set-up screen will be Set Number of People.



3. Press the SELECT keypad to set your hardness level.

### ► **SET NUMBER OF PEOPLE** .....

1. If a hardness level was selected in the previous step, you will set the Number of People in the household. Default is 3. Press the UP or DOWN keypads to select correct number.

2. Press the SELECT keypad to set.

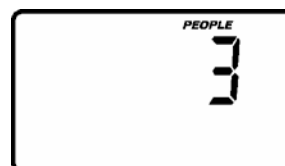

### ► **SET DAYS BETWEEN RECHARGE** .....

1. If the hardness level was set to OFF, the number of Days Between Recharges must be set. Press the UP or DOWN keypads to select.

2. Press the SELECT keypad to set.



### ► **SET RECHARGE TIME** .....

1. The timer default is set to recharge at 2:00 AM. If a different time is necessary, press the UP or DOWN keypads to change the recharge time. Be sure AM or PM, as applies, also shows.

2. Press the SELECT keypad to set and return the timer to the normal run display.



## FEATURES (SOFTENERS)

### ► **SET CAPACITY** .....

1. The circuit board determines this number based on the initial timer board programming. If you want to change the capacity, do the following steps.
2. Press and hold the SELECT keypad to display the following screen. Press the SELECT keypad until the Set Capacity screen is displayed.
3. Press the UP or DOWN keypad to set either CAP 1, CAP 2 or CAP 3. CAP 1 is the highest efficiency setting, meaning at CAP 1, the softener will use salt

more efficiently, but regenerate more often. The setting CAP 3 is the highest capacity of the three settings. This means the softener will have the highest softening capacity, regenerate less frequently, but will use more salt over time.



### ► **VIEW DAYS TO RECHARGE** .....

1. This view only display shows the number of days the softener will run before recharging. This display shows only if "OFF" is not the hardness setting.
2. Press and hold the SELECT keypad to display the following screen. Press the SELECT keypad until the View Days to Recharge screen is displayed.

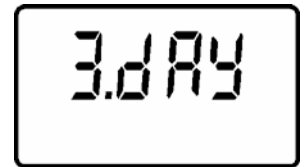

**NOTE:** The default settings for backwash and fast rinse cycles of regeneration are factory set for maximum performance of the softener. Use the following procedures to check for correct cycle times, or to change if desired. However, only trained technicians should change the time settings.

### ► **ADJUSTABLE BACKWASH** .....

1. Press and hold the SELECT button until the display shows "000--". Press the SELECT keypad until the Backwash time adjust screen is displayed.
2. Using the UP or DOWN keypads, adjust the backwash time from 0 minutes to 60 minutes.

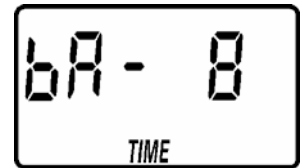
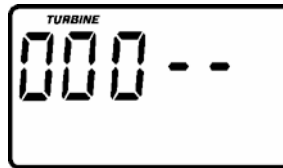

### ► **ADJUSTABLE FAST RINSE** .....

1. Press and hold the SELECT button until the display shows "000--". Press the SELECT keypad until the Fast Rinse time adjust screen is displayed.
2. Using the UP or DOWN keypads, adjust the fast rinse time from 0 minutes to 60 minutes.

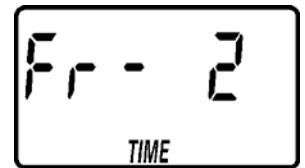

## SETTING THE TIMER (TANNIN FILTER)

### ► **SET PRESENT TIME** .....

1. Press the UP or DOWN keypads to set the present time of day. Be sure AM or PM, as applies, also shows.



2. Press the SELECT keypad to set the present time.



### ► **SET DAYS BETWEEN RECHARGE** .....

1. This setting is the number of days the filter will go between recharges. The default setting is 2 days, with a maximum setting of 99.

2. Press the SELECT keypad to set.



### ► **SET RECHARGE TIME** .....

1. The timer default is set to recharge at 2:00 AM. If a different time is necessary, press the UP or DOWN keypads to change the recharge time. Be sure AM or PM, as applies, also shows.

2. Press the SELECT keypad to set and return the timer to the normal run display.



## FEATURES (TANNIN FILTERS)

### ► **ADJUSTABLE FILL** .....

1. Press and hold the SELECT button until the display shows "000--", then press the SELECT button once to advance to the Fill time adjust screen.

2. Using the UP or DOWN buttons, adjust the fill time from 0 minutes to 12 minutes.



### ► **ADJUSTABLE BRINE DRAW** .....

1. Press and hold the SELECT button until the display shows "000--", then press the SELECT button twice to advance to the Brine Draw time adjust screen.

2. Using the UP or DOWN buttons, adjust the brine draw time from 0 minutes to 255 minutes.



### ► **ADJUSTABLE BACKWASH** .....

1. Press and hold the SELECT button until the display shows "000--", then press the SELECT button three times to advance to the Backwash time adjust screen.

2. Using the UP or DOWN buttons, adjust the backwash time from 0 minutes to 60 minutes.

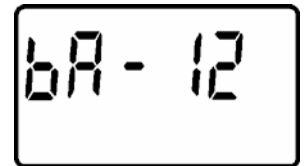

### ► **ADJUSTABLE FST RINSE** .....

1. Press and hold the SELECT button until the display shows "000--", then press the SELECT button four times to advance to the Fast Rinse time adjust screen.

2. Using the UP or DOWN buttons, adjust the fast rinse time from 0 minutes to 60 minutes.

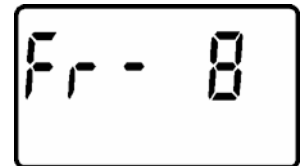

## FEATURES (ALL MODELS)

### **RECHARGE NOW** .....

If you have used, or plan to use, more water than usual (house guests, extra washing, etc.), you could run out of soft or filtered water before the next scheduled regeneration occurs. To be assured this will not happen, press and hold the RECHARGE keypad until **RECHARGE NOW** begins to flash in the time display. A regeneration begins immediately, and it

will last for about 2 hours. When over, you will have a full supply of soft or filtered water.

NOTE: Avoid using HOT water during the regeneration, because the water heater will refill with hard water.

### **VACATION CONTROL** .....

Before going on vacation, or other long absence, press and release the RECHARGE keypad so **VAC** starts to flash in the display. The timer continues to keep time, but regenerations will not occur to waste water and salt.

When you return, touch the RECHARGE keypad again to return the softener/filter to service, and the present time in the display. **REMEMBER TO DO THIS**, or the unit will not regenerate and you will soon have hard or unfiltered water.

### **AUTOMATIC ELECTRONIC DIAGNOSTICS** .....

The faceplate has a self-diagnostic function for the electrical system (except input power). The faceplate monitors electronic components and circuits for correct operation. If a malfunction occurs, an error code appears in the faceplate display.

The chart below shows the error codes that could

appear, and the possible defects for each code.

While an error code appears in the display, all faceplate keypads are inoperable except the RECHARGE keypad. RECHARGE remains operational so the service person can make the *Manual Advance Diagnostics* to further isolate the defect.

CODE	POSSIBLE DEFECT	
	MOST LIKELY ▶	▶ LEAST LIKELY
Err 01, Err 03 & Err 04	wiring harness or connection to position switch / switch / valve defect causing high torque / motor inoperative	
Err 05	faceplate	

**PROCEDURE FOR REMOVING ERROR CODE FROM FACEPLATE:** 1. Unplug transformer---- 2. Correct defect---- 3. Plug in transformer---- 4. Wait for 12 minutes. The error code will return if the defect was not corrected. Press and hold the *RECHARGE* keypad for 3 seconds as an alternate way to clear an error code.

# REPAIR PARTS

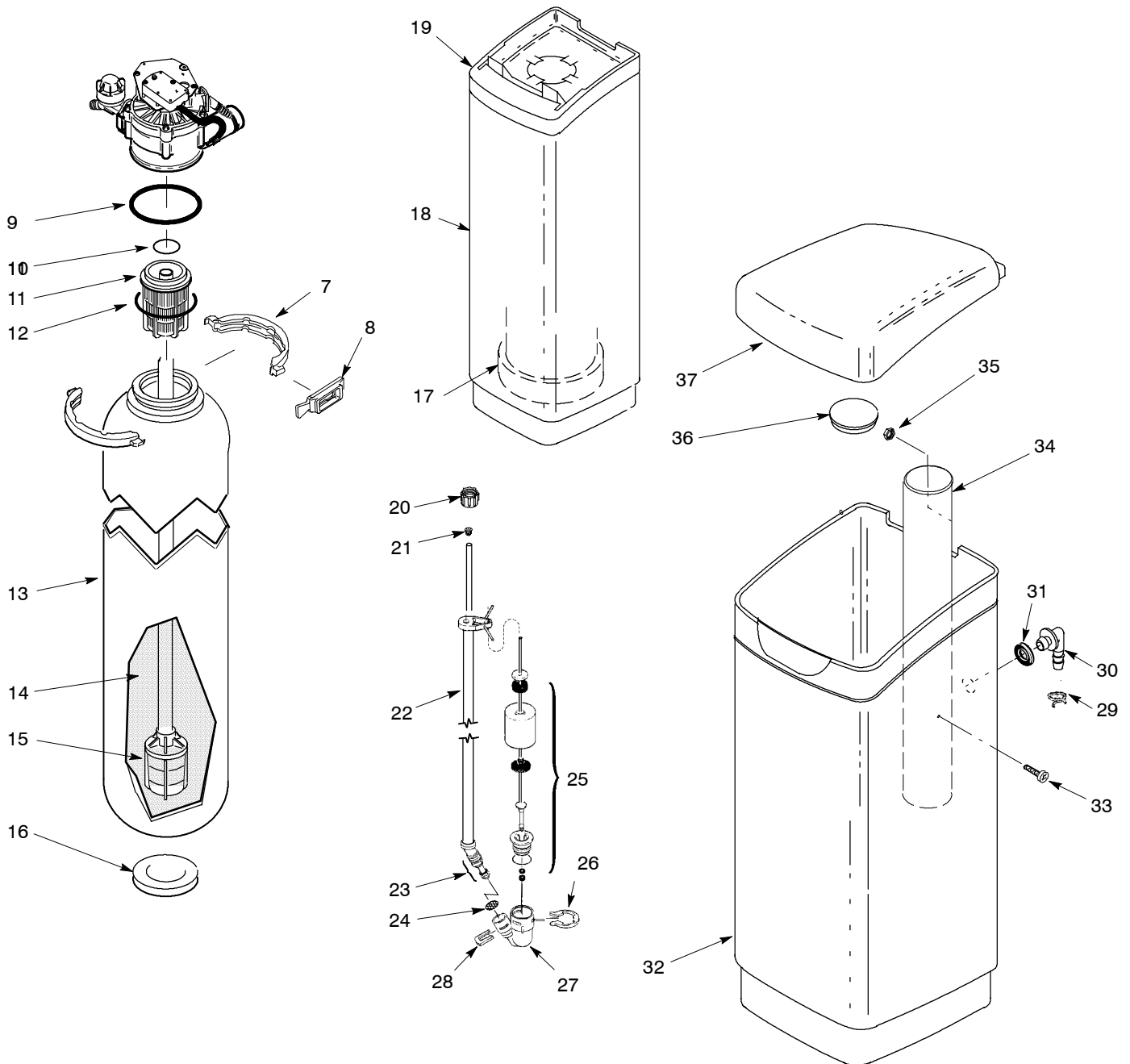
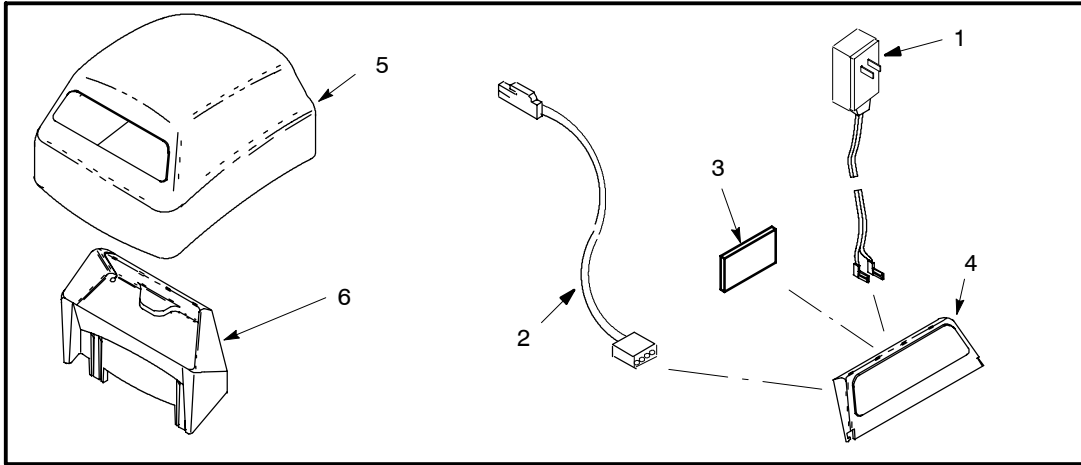

## REPAIR PARTS

KEY NO.	PART NO.	DESCRIPTION
1	7252373	Transformer, 24V - 10VA
2	7259927	Wire Harness (switch)
3	7260059	Rep'l PWA
4	7210509	Faceplate, order following decal
-	7259901	Decal, Faceplate
5	7210478	Top Cover
6	7211173	Faceplate Support
7	7176292	Clamp Section, 2 req.
8	7088033	Clamp Retainer, 2 req
9	7170296	O-ring Seal, 2-7/8" x 3-1/4"
10	7170254	O-ring, 13/16" x 1-1/16"
11	7077870	Top Distributor
12	7170270	O-ring, 2-3/4" x 3"
13	7113058	Resin Tank, 8" dia. x 40" (R24)
	7092202	Resin Tank, 10" dia. x 47" (R32)
14	0502272	Resin, 1 cu ft <sup>1</sup>
	0501741	Resin, 1/2 cu ft <sup>1</sup>
15	7105047	Repl. Distributor
16	1184700	Spacer (R24 only)
17	7141205	Tank Support
18	7218620	Sleeve (R24)
	7218646	Sleeve (R32)

KEY NO.	PART NO.	DESCRIPTION
19	7210460	Rim
20	1202600	Nut-Ferrule
21	7171349	Screen
22	7113016	Tubing Asm., Brine Valve
23	7095470	Brine Tube
24	7131365	Screen
25	7113008	Float, Stem & Guide
26	1205500	Clip
27	7092252	Brine Valve Body
28	7080653	Clip
29	0900431	Hose Clamp
30	1103200	Hose Adaptor
31	9003500	Grommet
32	7218612	Brine Tank
33	7219587	Screw
34	7109871	Brinewell
35	7219595	Washer
36	7155115	Brinewell Cover
37	7210486	Brine Tank Cover
■	7116488	Brine Valve Asm. (incl. key nos. 22 - 28)

<sup>1</sup> R24 uses 3/4 cu ft (40 lbs), R32 uses 1 cu ft or 1-1/4 cu ft.

# REPAIR PARTS

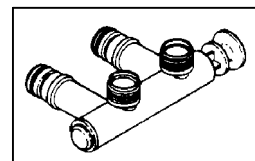
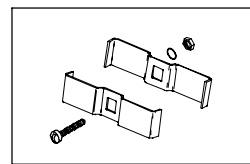
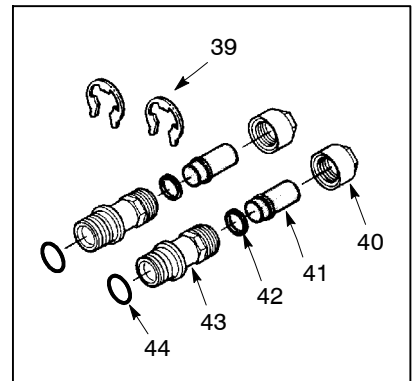
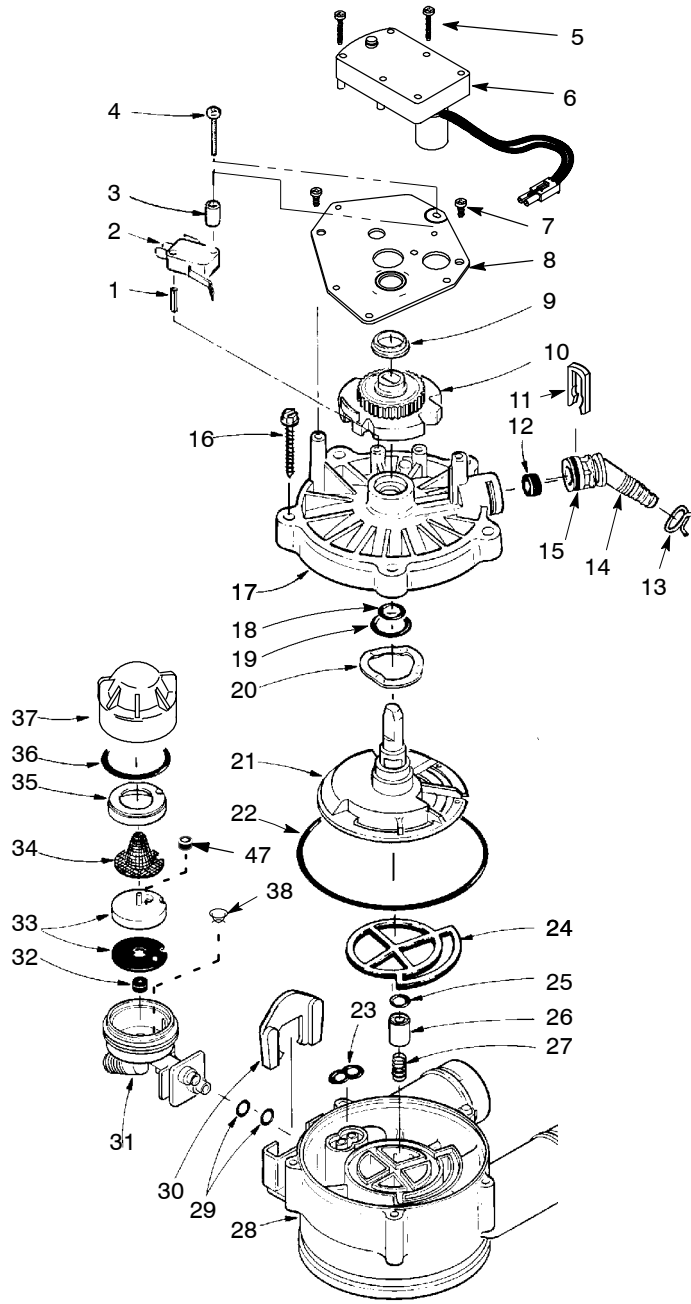

## REPAIR PARTS

KEY NO.	PART NO.	PART DESCRIPTION
1	7077472	Expansion Pin
2	7030713	Switch
3	7117816	Spacer
4	7070412	Screw, #4-24 x 1-1/8"
5	7224087	Screw, #8-32 x 1" (2)
6	7234731	Motor
7	0900857	Screw, #6-20 x 3/8" (2)
8	7231385	Motor Plate
9	0503288	Bearing
10	7113927	Cam and Gear
11	7142942	Clip (drain)
12	0501228	Flow Plug, #18 (R24)
	7092618	Flow Plug, 2.0 (R32)
13	0900431	Hose Clamp
14	7024160	Drain Hose Adaptor
15	7170327	O-ring, 5/8" x 13/16"
16	7074123	Screw, #10-14 x 2 (5)
17	7085263	Valve Cover
18	7170238	O-ring, 7/16" x 5/8"
19	7170212	O-ring, 3/4" x 15/16"
20	7082087	Wave Washer
21	7199232	Rotor & Disc
22	7170246	O-ring, 3-3/8" x 3-5/8"
23	7081764	Seal (nozzle & venturi)
24	7134224	Rotor Seal
25	7170204	O-ring, 3/8" x 9/16"
26	7092642	Plug (drain seal)
27	7129889	Spring
28	7082053	Valve Body
29	7170319	O-ring, 1/4" x 3/8" (2)

KEY NO.	PART NO.	PART DESCRIPTION
30	7081201	Retainer (nozzle & venturi)
31	7081104	Nozzle & Venturi Housing
32	1148800	Flow Plug, .3 gpm
33	7187772	Nozzle & Venturi -Gasket Kit (R24)
	7114533	Nozzle & Venturi -Gasket Kit (R32)
-	7204362	Gasket (only)
34	7146043	Screen
35	7167659	Screen Support
36	7170262	O-ring, 1-3/16" x 1-3/8"
37	7199729	Cap
38	7095030	Cone Screen
39	7116713	Clip (2)
40	0507369	Installation Nut (2)
41	0507615	Installation Tube (2)
42	7170335	Washer (2)
43	2207800	Installation Adaptor (2) - incl. key no. 44
44	7170288	O-ring, 15/16" x 1-3/16" (2)
45	7248706	Ground Clamp Kit
46	7129871	Bypass Valve (optional - not included)
47	521829	Flow Plug, .1 gpm (R24)
	7084607	Flow Plug, .15 gpm (R32)
■	7187065	Nozzle & Venturi Asm. (R24)
	7253808	Nozzle & Venturi Asm. (R32)
■	7129716	Seal Kit (incl. key nos. 18, 19, 22 - 25)
■	7125982	Repl. Valve (incl. key nos. 16 - 28)