

P/N: 7255842
(Rev. C 7/8/04)

SHIPMENT INSPECTION

Thoroughly check the commercial system for possible shipping damage and/or parts loss. Also inspect and note any damage to shipping cartons, crating, etc. If damage is present, notify the transportation company. The manufacturer is not responsible for damage or parts loss in shipment.

Note: Do not mistakenly discard small parts bags when unpacking the system.

All models are shipped in 2 cartons; (1) mineral tank and (2) controller. The mineral bed consists of 1 cubic foot bags of filtering media, and 17 or 50 pound bags of various grades of gravel. Refer to the following chart.

Note: Some models use only partial bags of media. See loading table on page 7.

MEDIA SHIPPED WITH UNITS							
MODEL	GRAVEL 7124415 17 lb. bag	GRAVEL 7124423 50 lb. bag	GARNET 993090 50 lb. bag	FILTER SAND 993080 50 lb. bag	MANGANESE GREENSAND 501676 1 cu. ft. bag	ANTHRACITE 993070 1 cu. ft. bag	CARBON 3424509 1 cu. ft. bag
EMPTY							
121XS	2						
121XD	4						
121XT	6						
121XQ	8						
171XS		2					
171XD		4					
171XT		6					
171XQ		8					
CARBON							
121CS	1						2
121CD	2						4
121CT	3						6
121CQ	4						8
171CS		2					4
171CD		4					8
171CT		6					12
171CQ		8					16
MULTI-MEDIA							
121MS	2		1*	1		1	
121MD	4		1	2		2	
121MT	6		2*	3		3	
121MQ	8		2	4		4	
GREENSAND							
121GS	1		1*		2*	1*	
121GD	2		1		3	1	
121GT	3		2*		5*	2*	
121GQ	4		2		6	2	

* Partial bag.

TABLE OF CONTENTS

	Page No.
Specifications	4
Dimensions	5
Media Loading and Assembly	6 - 7
Installation	
Installation Steps	7 - 8
Inlet - Outlet Plumbing Drawing	8
Notes and Cautions	9
Connect Valve Drain Hose	9
Pressure Testing	10
Programming the Controller	11-12
Resetting Time	13
Controller Features and Options	13-16
Operation	
Demand Controller and Water Meter	16
Water Flow Through the Filter	17 - 18
Service Information	
Wiring Schematic	19
Error Code Table	20
Troubleshooting	21
Repair Parts	
Mineral Tanks / Distributor / Controller	22-23
Valve Assembly	24-25

SAFETY GUIDES

Follow the installation instructions carefully. Failure to install the commercial system properly voids the warranty.

Before you begin installation, read this entire manual. Then, obtain all the materials and tools you will need to make the installation.

Check local plumbing and electrical codes. The installation must conform to them.

Use only lead-free solder and flux for all sweat-solder connections, as required by state and federal codes.

Do not locate this system where freezing temperatures occur. Do not attempt to treat water over 100°F. **Freezing, or hot water damage voids the warranty.**

Avoid installing in direct sunlight. **Excessive sun heat may cause distortion or other damage** to non-metallic parts.

This system requires a minimum water pressure of 30 psi at the inlet. **MAXIMUM ALLOWABLE Inlet water pressure is 125 psi.** If daytime pressure is over 80 psi, nighttime pressure may exceed the maximum. Use a pressure reducing valve if necessary. (Adding a pressure reducing valve may reduce the flow.)

The system works on 24 volt-60 Hz electrical power only. Be sure to use the included transformer.

This system is not intended to be used for treating water that is microbiologically unsafe or of unknown quality without adequate disinfection before or after the system.

SPECIFICATIONS

EQUIPMENT SPECIFICATIONS (based on single units)							
MODEL	FILTERS						
	ALL PURPOSE		CARBON		MULTI-MEDIA	GREENSAND	
	121XS	171XS	121CS	171CS	121MS	121GS	
TANK SIZE (IN)	12" x 54"	17" x 58"	12" x 54"	17" x 58"	12" x 54"	12" x 54"	
RECOMMENDED SERVICE WATER FLOW RATE (GPM)	4 - 8	8 - 16	4 - 8	8 - 16	4 - 8	4 - 8	
CONTAMINANT REMOVAL	based on water analysis					maximum iron 20 ppm	
FLOW RATES (GPM @ PSI)	2 GPM			1.0 ΔP	0.6 ΔP	1.0 ΔP	1.0 ΔP
	4 GPM			2.3 ΔP	1.1 ΔP	2.3 ΔP	2.3 ΔP
	6 GPM			3.9 ΔP	2.2 ΔP	3.9 ΔP	3.9 ΔP
	8 GPM			5.7 ΔP	3.3 ΔP	5.7 ΔP	5.7 ΔP
	10 GPM			7.9 ΔP	4.6 ΔP	7.9 ΔP	7.9 ΔP
	12 GPM			N/A	5.9 ΔP	N/A	N/A
	14 GPM			N/A	7.4 ΔP	N/A	N/A
	16 GPM			N/A	9.7 ΔP	N/A	N/A
	18 GPM			N/A	N/A	N/A	N/A
MINERAL LOADING CUBIC FT. OF MINERAL (LBS) *Use only partial bags of supplied mineral	ANTHRACITE	-	-	-	-	1 (52#)*	.5 (26#)*
	FILTER SAND	-	-	-	-	.5 (50#)	-
	GARNET	-	-	-	-	.19 (25#)*	.19 (25#)*
	ACTIVATED CARBON	-	-	2 (84#)	4 (168#)	-	-
	MANGANESE GREENSAND	-	-	-	-	-	1.5 (128#)*
	GRAVEL	.17 (17#)	1 (100#)	.17 (17#)	1 (100#)	.34 (34#)	.17 (17#)
BKW/FR FLOW RATES	LOCATION	Key #10, page 24					
	(GAL/MIN)	7	15	7	15	10	10
PIPE SIZE (IN)		1"	1"	1"	1"	1"	1"
	W/ADAPTOR❖	1-1/2"	1-1/2"	1-1/2"	1-1/2"	1-1/2"	1-1/2"
WATER PRESSURE LIMITS (PSI)	30 - 125						
MAX. WATER TEMPERATURE (°F)	35 - 100						
ELECTRICAL RATING	24v 60Hz						

dependant on media

❖ Optional 1-1/2" sweat fittings available, part number 7129211, 2 per package.

Note: Pressure drop figures are valid only with a clean bed.

DIMENSIONS

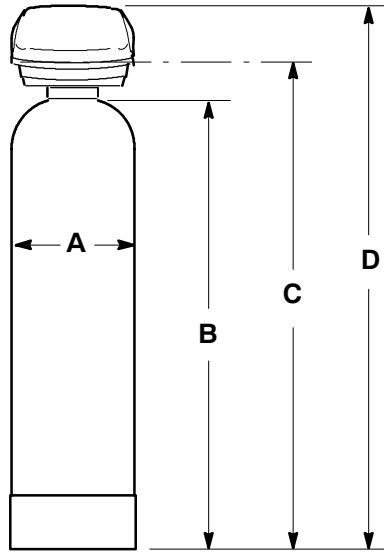

MODEL	A	B	C	D	INLET – OUTLET	
	Resin Tank Diameter	Resin Tank Height	Inlet – Outlet Height	Overall Height	Pipe Size ¹	Center lines
121	12.3"	55"	57"	65.75"	1"	3.8"
171	17.6"	59.5"	61.5"	70.25"	1"	3.8"

¹ Sweat copper (1") fittings supplied. Optional 1-1/2" fittings available, part no. 7129211, package of 2.

MEDIA LOADING AND ASSEMBLY

1. Move the resin tank into installation location (see page 7). Set it on a flat, level surface. If a multiple installation, allow space between tanks for servicing equipment.

2. Remove the shipping cap, top distributor and o-rings. On **all models**, place the *bottom* distributor into the resin tank. Check the distributor length as shown in Figure 1 and adjust if needed. Center the distributor in the tank.

3. With a pail or hose, fill the tank with 1 to 2 feet of water. The water acts as a cushion to protect the bottom distributor while filling the tank with gravel and media.

4. Plug the top end of the distributor tube with a clean rag, duct tape, cap, etc. to keep gravel and media out.

5. Using a large neck funnel, add the specified amount of gravel (see page 2). **Be sure the distributor remains centered.**

6. Add the specified amount of media in the correct sequence (see Figure 2). Use water sparingly to speed media flow through the funnel (it may be necessary to siphon water from the bottom of distributor if tank becomes full of water). See Loading Table, page 7.

7. Flush the tank opening with water to clean media from the top of the tank. Unplug distributor.

8. Finish filling the tank with water, up to the top of the tank.

Important: Be sure to fill with water. This will eliminate air space and prevent excessive air-head pressure when the water conditioner is pressurized.

9. Install the o-ring seals and top distributor exactly as shown in Figure 3. If the o-rings need lubrication, use a high quality silicone grease.

Note: The distributor (strainer style) that is included with the mineral tank assembly is not used. Replace the distributor with the correct top distributor for filters (with three large square holes) that is packed with the valve.

Figure 1

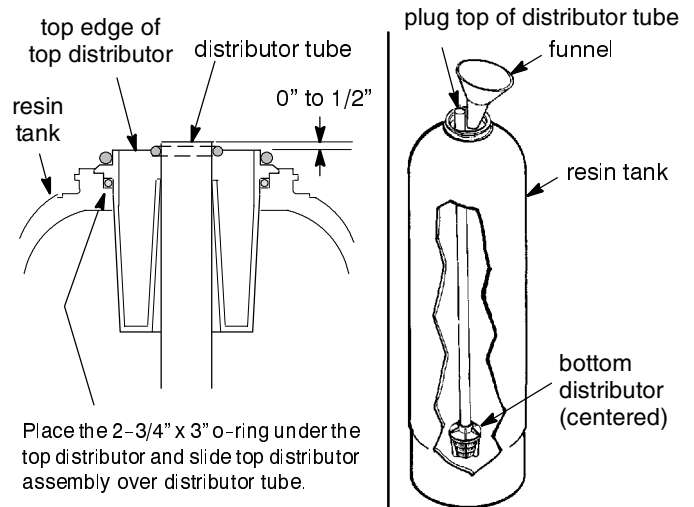

Note: Resin tank height can vary somewhat within manufacturing tolerance. **To assure the bottom distributor riser pipe has proper clearance with inside valve porting, check for the correct length as shown above.** Cut the riser if needed to adjust the length. Be sure to remove burrs and sharp edges.

Figure 2

BEDDING SEQUENCE OF GRAVEL AND MINERALS

NOTE: Be sure distributor assembly is centered in tank before filling.

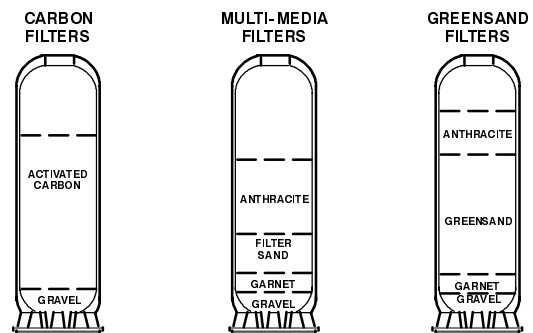
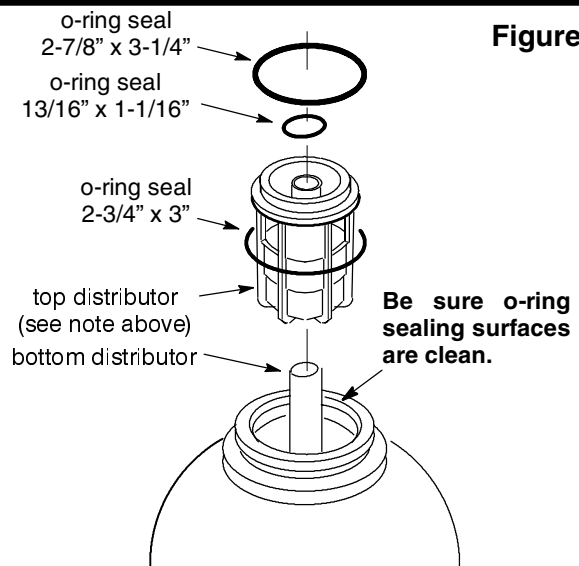

Figure 3



MEDIA LOADING AND ASSEMBLY

Figure 4

10. Lower the valve assembly onto the resin tank, centering over the bottom distributor tube. Push downward, against the o-ring, and install the clamp sections, securing with the retainers.

Important: Check the valve outlet to be sure the turbine and turbine support are securely in place.

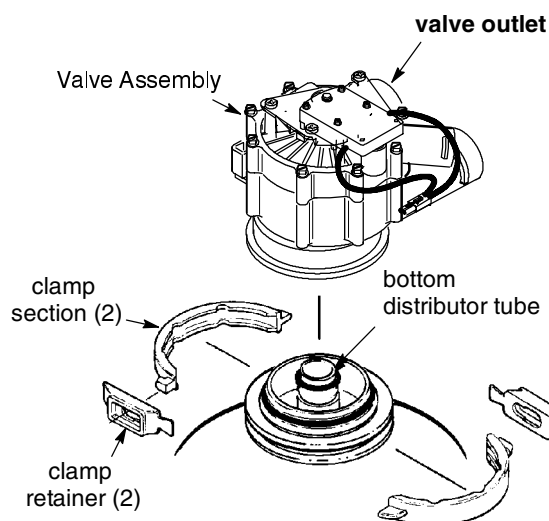

INDIVIDUAL FILTER TANK LOADING								
			EMPTY MODEL 121XS	CARBON MODEL 121CS	MULTIMEDIA MODEL 121MS	MANGANESE GREENSAND MODEL 121GS	EMPTY MODEL 171XS	CARBON MODEL 171CS
MEDIA	PART NUMBER	CUBIC FT. PER BAG	(# of bags)	(# of bags)	(# of bags)	(# of bags)	(# of bags)	(# of bags)
GRAVEL	7124415	0.17	1	1	2	1		
GRAVEL	7124423	0.5					1	2
GARNET	993090	0.38			0.5*	0.5*		
FILTER SAND	993080	0.5			1			
MANGANESE GREENSAND	501676	1				1.5*		
ANTHRACITE	993070	1			1	0.5*		
CARBON	3424509	1		2				

* Not all media shipped with the unit is loaded in tanks, 1/2 bag will be unused.

PLANS FOR LOCATION AND INSTALLATION OF SYSTEM

WATER SUPPLY: The system requires a potable water supply that will provide a continuous flow to meet regeneration flow specifications. A minimum pressure of 30 psi is required at the filter inlet.

“FULL LINE” (both hot and cold water) WATER TREATMENT: Connect the system to the water supply pipe immediately *after* (downstream) the municipal supply water meter or well supply pressure tank.

TREATING HOT WATER ONLY: Connect the system to the water supply pipe *before* (upstream) the water heater.

CAUTIONS: (1) Do not install the filter *after*, or downstream from the water heater. *Hot water will damage* inner parts of the system. (2) To reduce the risk of hot water flowing backwards into the filter, piping between the filter and water heater should be as long as possible.

DRAIN: A drain is needed nearby the filter, capable of carrying away backwash water at the rate of flow listed in the specifications. A floor drain is preferred. Other approved drain points are acceptable if they do not cause a back-pressure on the conditioner drain hose or pipe.

ELECTRICAL: The system works on **24 volts only**. A transformer is included to reduce 120V-60Hz electrical power. An approved, grounded outlet is needed within 10' of the conditioner controller for the transformer. The conditioner includes a 10' power cable to connect between the transformer and the controller. The controller may be mounted in any convenient location. You may either fasten to a wall using the mounting holes molded in the controller case, or wrap a chain around the tank and connected to the mounting holes on controller case.

SPACE REQUIREMENTS: Be sure to allow sufficient area around the resin tank(s) for maintenance and other service. Dimensions are shown on page 5.

MATERIALS YOU MAY NEED

Use the drawing at the right as a guide for your installation. The drawing shows typical connection using fittings included with the system, and with optional items available.

■ Be sure to install a 3-valve bypass system, or use the **optional bypass valve, #7195408**. Bypass valves allow you to turn off water to the system, for servicing, while having full-line bypass to the establishment.

■ A **5/8" minimum** inside diameter hose or pipe is required for the valve drain (see page 9). The drain fitting has standard garden hose threads, and hose barbs. Adaptors are available from most hardware stores to convert the fitting to accept rigid pipe.

■ For in and out pipes to the filter, use copper, CPVC plastic or threaded pipe and fittings. Avoid joining copper and galvanized together as corrosion will occur rapidly. Included inlet and outlet adaptors are 1" male copper. Optional fittings available are shown in Figure 6.

■ **Multiple Tank Installations:** Balanced flow header, as shown in Figure 5, must be used when plumbing multiple tank systems.

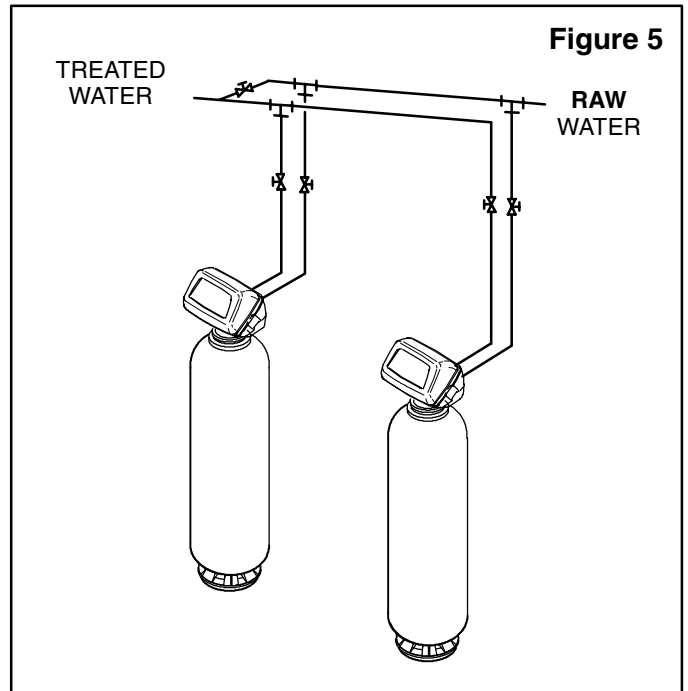
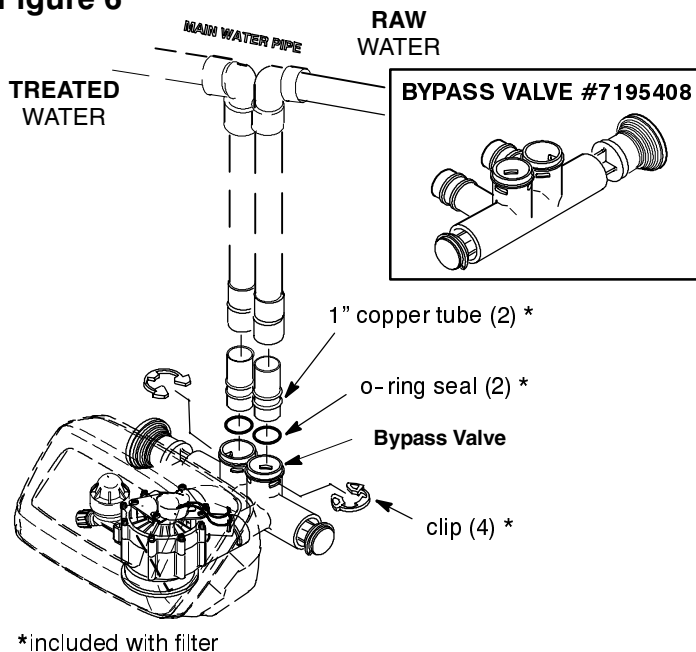





Figure 5

TYPICAL INLET- OUTLET PLUMBING CONNECTIONS

Figure 6



OPTIONAL INLET/OUTLET FITTINGS

-  — #7104546 CPVC Nipple - Use in place of included copper inlet and outlet tubes.
-  — #7129211 Adaptor Fitting, 1-1/2" (2) - Use in place of included copper inlet and outlet tubes.
-  — #7120259 Elbow - Extends inlet and/or outlet in any 90° direction.

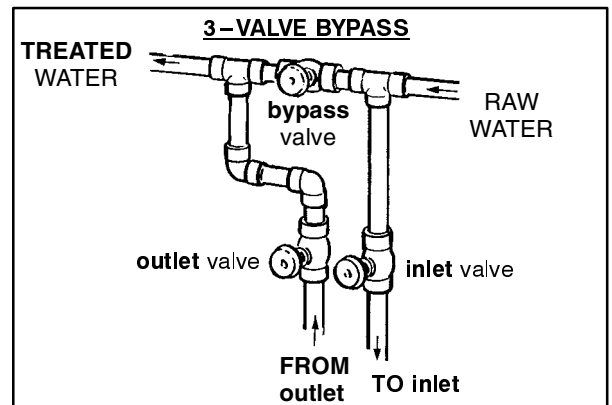

INSTALLATION STEPS

PIPING ASSEMBLY NOTES AND CAUTIONS:

- BE SURE to **close the main water supply valve** before beginning.
- BE SURE to plumb so **hard water flows to the valve inlet** fitting.
- **CAUTION:** When soldering, make sub-assemblies as needed to **prevent soldering heat damage** to the filter valve or bypass valve. Be sure soldered piping has cooled before connecting to the filter.
- Use Teflon tape or pipe joint compound on external pipe threads.
- Lubricate o-ring seals with high quality silicone grease.

1. Looking at the illustrations on page 8, and observing the notes above, run piping from the main **water supply pipe to the valve inlet**. Then, run return piping from the valve outlet to the supply pipe. Be sure to include a 3-valve bypass, or use one of the optional bypass valves.

Note: When working with soldered copper, be sure to observe the caution above to avoid damage to non-metallic parts.

Important: Support in and out piping in an acceptable manner, to prevent weight stress on the conditioner valve.

2. **Install Valve Drain Hose:** The drain fitting accepts a garden hose connection.

- **Fasten the hose in place** at the drain point. Pressurized water, exiting the hose during regenerations, could cause it to “whip”.
- Provide an air-gap of at least 1–1/2” between the end of the hose and the floor drain cover. The air-gap prevents a possible back siphon if sewer water should backup.
- For longer or raised drain hose runs, a 3/4” dia. hose (minimum) is recommended to reduce back-pressure. Back-pressure can restrict flow through the valve during backwash.
- If codes require a rigid drain pipe, purchase an adaptor fitting, available from most hardware stores.

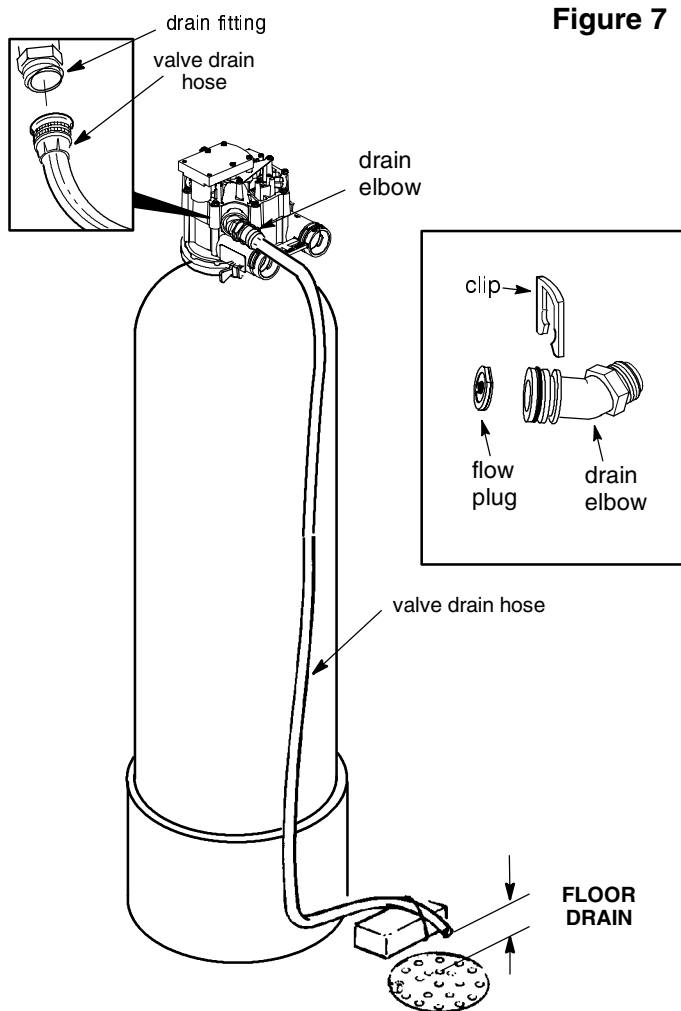

Figure 7

CONNECTING A RIGID VALVE DRAIN TUBE

To adapt a rigid drain tube to the softener, buy an adaptor (garden hose thread x 3/4” NPT) and needed connectors and tubing from your local hardware store.

INSTALLATION STEPS

3. Pressure Testing: To prevent excessive air pressure in the resin tank and plumbing system, do the following steps in exact order.

- 1 Open two or more **filtered** water faucets, both hot and cold.
- 2 Referring to Figure 8, place the bypass valve(s) in “service”.
- 3 Slowly open the main water supply valve, pausing several times to allow the system to pressurize. When water from opened faucets runs smoothly, with no more air bubbles, close the faucets.
- 4 Check the installation for leaks. If any rework is needed, observe the cautions on page 9.

4. Connect the controller cable(s) to the controller. Be sure the screws are tight. Note: The transformer must be unplugged before connecting or disconnecting controller cables. If not, it may result in damage to the controller circuits.

5. Connect the power cable to the two screw terminals on the transformer. Be sure the screws are tight. Plug the transformer into a 120V-60HZ outlet.

6. Program the controller to complete installation.

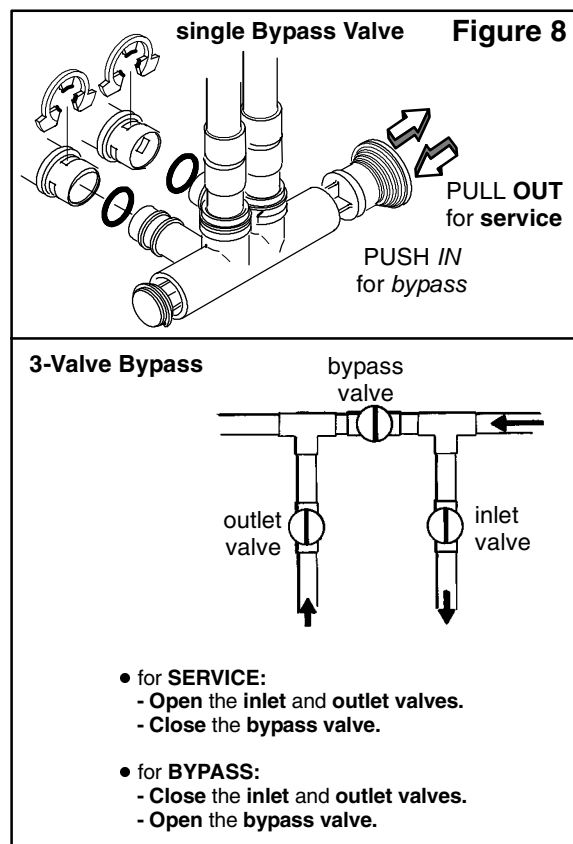

PROGRAMMING THE ELECTRONIC CONTROLLER AT STARTUP

(See page 13 to reset time and other settings, once programmed)

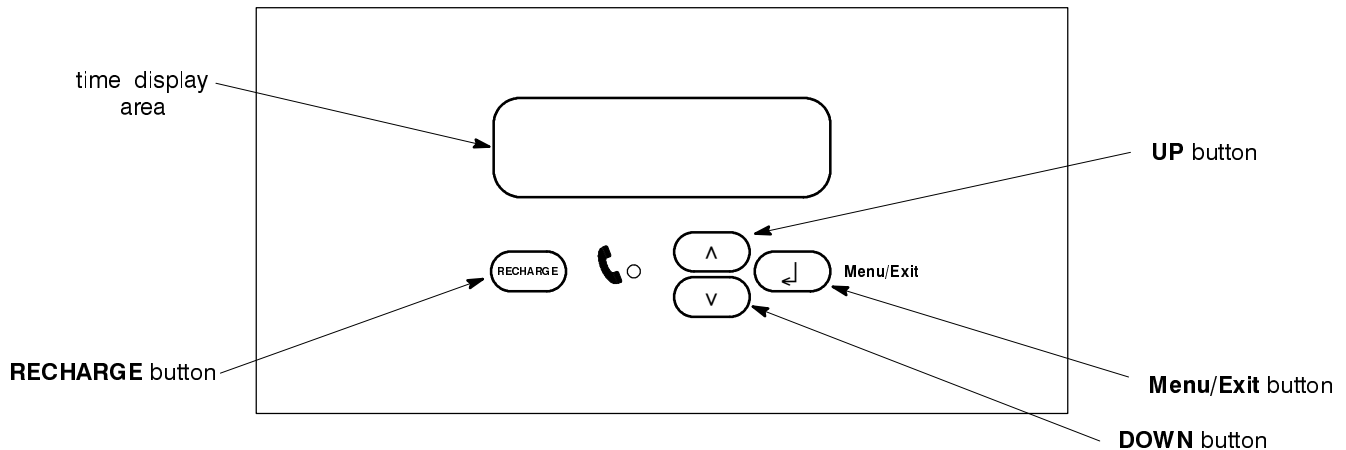

The electronic controller is a menu driven system with a dot matrix display. The Up (↑) and Down (↓) buttons move the cursor (>) up and down the menu choices. The Menu/Exit (↵) button enters the value selected and returns the display back a level. The controller will return to the normal operating screen after 4 minutes if left in a menu and no selection has been made.

● **SOUND “BEEPER”**- A “beeper” sounds while pressing buttons for controller setup. One beep signals a change in the faceplate display. Repeated beeps means the controller will not accept a change from the button you have pressed, telling you to use another button.

When the transformer is first plugged in, a screen is displayed for approximately 8 seconds showing the software version, then the following screens are displayed to program the controller.

1. SET LANGUAGE: Using the up (↑) or down (↓) buttons, move the cursor (>) next to the preferred language. Press the Menu/Exit (↵) button to select and advance to next setting.

```
-----
Version : C2.2
```

2. SET VALVE TYPE: Use the up (↑) or down (↓) buttons to display 1 inch single rotor disc valve. When the correct application is shown, press the Menu/Exit (↵) button to select and advance to next setting.

```
> English
  Español
  Français
↑↓ Change           ↵ Exit
```

3. SET NUMBER OF VALVES: If one filter is installed, set Simplex in the display using the up (↑) or down (↓) buttons, press the Menu/Exit (↵) button to select and advance to next setting. If multiple units are installed, set for Duplex, Triplex or Quadplex as applies for the installation.

```
Set Valve
Type:
One Inch Single Disk
↑↓ Change           ↵ Next
```

4. SET RECHARGE METHOD (for multiple tank applications only): There are four choices for recharge method: Peak Flow, Alt. Immediate, Parallel Immediate or Parallel Delayed. When Peak Flow is selected, each tank recharges as capacity is used. Alt. Immediate initiates an immediate recharge on a tank as capacity is used. When that tank is finished recharging it is put in standby mode. Parallel Immediate recharges each tank in sequence immediately as capacity is used. Parallel Delayed recharges each tank in sequence at the scheduled recharge time. Using the up (↑) or down (↓) button, select recharge method and press the Menu/Exit (↵) button to select and advance to next setting.

```
Set Number of
Valves:
Quadplex
↑↓ Change           ↵ Next
```

```
Set Recharge
Method:
Parallel Delayed
↑↓ Change           ↵ Next
```

5. SET SYSTEM TYPE: Using the up (↑) or down (↓) button, select filter system type and press the Menu/Exit (↵) button to select and advance to next setting. If filter is selected, go to step 6 on page 12, for further settings.

```
Set System
Type:
Filter
↑↓ Change           ↵ Next
```

continued

PROGRAMMING THE ELECTRONIC CONTROLLER AT STARTUP

6. SET FILTER CAPACITY: Using the up (↑) or down (↓) button, select OFF, or a pre chosen number of gallons, in 1000 gallon increments, at which you want the filter to backwash. If OFF is selected, the filter will not backwash automatically, and it must be initiated manually. Press the Menu/Exit (↵) button to select and advance to next setting.

Set Filter Capacity: 1000	
↑↓ Change	↵ Next

7. SET FIXED RESERVE: (Simplex or Parallel Delayed Systems only) If a minimum capacity must be available on any given day, use the up (↑) or down (↓) button to select the percentage of filter operating capacity required. If Automatic is selected, the fixed reserve percentage varies, based on a weekly average of capacity used. Press the Menu/Exit (↵) button to select and advance to next setting.

Set Fixed Reserve: Automatic	
↑↓ Change	↵ Next

8. SET BACKWASH TIME: Using the up (↑) or down (↓) button, select backwash time from 1 minute minimum to 30 minutes maximum. The minimum recommended time for filters is about 15 minutes. Increase the time as needed to thoroughly clean the filter bed. Press the Menu/Exit (↵) button to select and advance to next setting.

Set Backwash Time: 15 Minutes	
↑↓ Change	↵ Next

9. SET FAST RINSE TIME: Using the up (↑) or down (↓) button, select fast rinse time from 1 minute minimum to 30 minutes maximum. The factory setting of 5 minutes is usually adequate. Press the Menu/Exit (↵) button to select and advance to next setting.

Set Fast Rinse Time: 5 Minutes	
↑↓ Change	↵ Next

10. SET MINIMUM TANKS IN SERVICE (Triplex and Quadplex units only): Using the up (↑) or down (↓) button, display the minimum number of tanks that are needed to be in service at a time. Press the Menu/Exit (↵) button to select and advance to next setting.

Set Minimum Tanks: In Service 3 Tanks	
↑↓ Change	↵ Next

11. SET PEAK FLOW TRIP POINT: If Peak Flow is selected (step 4), this option is activated. Using the up (↑) or down (↓) button, select the GPM (1.0 minimum to 750 maximum) at which you **temporarily** require another unit to come into service. The unit will come online when this GPM is reached. The unit will return to standby when a minimum of 30 minutes has elapsed and the GPM falls below the set point. Press the Menu/Exit (↵) button to select and advance to next setting.

Peak Flow Trippoint: 8.0 GPM	
↑↓ Change	↵ Next

After these initial settings are completed, the monitor will display a screen stating the controller is being reset and the controller will put the valve(s) through a cycle. The monitor will then show a screen with the current settings before moving to the next screen and required setting.

Filter 1 Inch Single Disc ----- Version : C2.0

12. SET CLOCK: Using the up (↑) or down (↓) button, set the present time, being sure AM or PM shows, as applicable. By pressing and holding either the up (↑) or down (↓) button, the display will scroll at faster increments. Press the Menu/Exit (↵) button to select and advance to next setting. Note: Clock will need to be reset only if power was out longer than 72 hours.

Set Clock: 12:00PM	
↑↓ Change	↵ Exit

13. SET RECHARGE TIME: This screen is active only if a single valve system or Parallel Delayed recharge setting. Using the up (↑) or down (↓) button, set the time when regenerations should start. Press the Menu/Exit (↵) button to select and advance to next setting.

Set Recharge Time: 12:00AM	
↑↓ Change	↵ Exit

The monitor returns to the normal operating screen when programming has been completed.

Water Flow Rate: 2.0 GPM	12:03 PM
↵ Menu	

The installation, and programming steps are complete.

ELECTRONIC CONTROLLER, RESETTING CONTROLLER, FEATURES AND OPTIONS

RESETTING TIME

To set the time if incorrect, or if the display is flashing after a power outage longer than 68 hours, reset as follows. When power is lost, all other settings are maintained by the computer and do not require setting (see Program Memory).

1. Press the Menu/Exit button (↵) to enter the Primary Menu. Using the up (↑) or down (↓) buttons, move the cursor (➤) to Set Clock and press (↵) to enter this menu.

```
EXIT
> Set Clock
  Set Hardness
  Set Recharge Time
```

2. Use the up (↑) and down (↓) buttons to set the correct time, being sure AM or PM shows, as applicable. Up (↑) advances the time; down (↓) moves the time backward.

```
Set Clock:
9:32PM
↑↓ Change                               ↵ Exit
```

3. When the correct time shows, press Menu/Exit (↵) to set the clock and return to the primary menu. Using the up (↑) or down (↓) buttons, move the cursor (➤) to EXIT and press Menu/Exit button (↵) and return to the normal operating screen.

```
Water                               9:32 PM
Flow Rate:
2.0 GPM
                                           ↵ Menu
```

FEATURES AND OPTIONS

RECHARGE: By pressing this button, the controller enters into the recharge menu. The options are Online/Offline, Recharge Now or Recharge Tonight. Move the cursor (➤) next to selection and press Menu/Exit (↵) button. Online/Offline allows a specific tank to be put online or taken offline. In the Recharge Now menu, you can select one or all tanks to start an immediate recharge. Move the cursor (➤) next to the specific tank and press the Menu/Exit (↵) button. This will start a recharge. In the Recharge Tonight menu, you can schedule a recharge or cancel a recharge tonight. Move the cursor (➤) next to the specific tank and press the Menu/Exit (↵) button. Use the up (↑) and down (↓) arrows to toggle between Service or Tonight.

```
>EXIT
  Online/ Offline
  Recharge Now
  Recharge Tonight
```

The following is a description of the features and options in the Primary Menu. To enter the Primary Menu, press the Menu/Exit (↵) button. Using the up (↑) or down (↓) button, move the cursor to the feature or option that you would like to change and press the Menu/Exit (↵) button to enter screen. To return to the normal operating screen, move the cursor (➤) to EXIT and press Menu/Exit button (↵).

SET CLOCK: Use the up (↑) and down (↓) buttons to set the correct time. If 12 hour clock is set, be sure AM or PM shows, as applies. Up (↑) advances the time; down (↓) moves the time backward. By pressing and holding either the up (↑) or down (↓) button, the display will scroll at faster increments. Press the Menu/Exit (↵) button to set and return to the Primary menu.

```
Set Clock:
9:32PM
↑↓ Change                               ↵ Exit
```

SET RECHARGE TIME: Using the up (↑) or down (↓) button, set the time when regenerations should start. Press the Menu/Exit (↵) button to set and return to the Primary menu. Move the cursor (➤) to EXIT and press Menu/Exit button (↵) and return to the normal operating screen. Note: This feature is available only on single or parallel delayed systems. If a softener or other water treatment equipment is being used, no more than one should backwash at a time.

```
Set Recharge
Time:
12:00AM
↑↓ Change                               ↵ Exit
```

FLOW RATE: This screen is for viewing the flow rate, in GPM or LPM, through each individual tank, depending on the configuration (simplex, duplex, etc.). Press the Menu/Exit (↵) button to return to the Primary menu. Move the cursor (➤) to EXIT and press Menu/Exit button (↵) and return to the normal operating screen.

```
T1: 2.5 GPM
T2: 3.1 GPM
T3: 1.6 GPM
T4: 2.8 GPM
                                           ↵ Exit
```

continued

FEATURES AND OPTIONS

WATER USED TODAY: This screen displays the number of gallons or liters that have been used in each individual tank per 24 hour time period, depending on the configuration (simplex, duplex, etc.). Press the Menu/Exit (↵) button to return to the Primary menu. Move the cursor (→) to EXIT and press Menu/Exit button (↵) and return to the normal operating screen.

T1: 5 Gallons
T2: 8 Gallons
T3: 4 Gallons
T4: 6 Gallons

AVG DAILY WATER USE: This screen displays the *average* number of gallons or liters that have been used in a 24 hour time period. Press the Menu/Exit (↵) button to return to the Primary menu. Move the cursor (→) to EXIT and press Menu/Exit button (↵) and return to the normal operating screen.

System Average Daily Water Use: 300 Gallons	↵ Exit
---	--------

CAPACITY REMAINING: This screen displays the percent capacity remaining in each individual tank, depending on the configuration (simplex, duplex, etc.). Press the Menu/Exit (↵) button to return to the Primary menu. Move the cursor (→) to EXIT and press Menu/Exit button (↵) and return to the normal operating screen. Note: Not available for filters that have Filter Gallons set to OFF (step 18). Screen will show “Filtering Water”.

Capacity Remaining %: T1: 25% T3: 48% T2: 33% T4: 37%	↵ Exit
--	--------

Filtering Water	12:22PM
↵ Exit	

SET 12/24 HOUR CLOCK: Using the up (↑) or down (↓) button, set the time to either a 12 or 24 hour clock. Press the Menu/Exit (↵) button to set and return to the Primary menu. Move the cursor (→) to EXIT and press Menu/Exit button (↵) and return to the normal operating screen.

Set 12/24 Hour Clock: 12 Hour	↵ Exit
↑↓ Change	

SET ENGLISH/METRIC: Using the up (↑) or down (↓) button, set the controller to measure in English or Metric units. Press the Menu/Exit (↵) button to set and return to the Primary menu. Move the cursor (→) to EXIT and press Menu/Exit button (↵) and return to the normal operating screen.

Set English/Metric	
English	↵ Exit
↑↓ Change	

SET ROLLING SCREEN: Using the up (↑) or down (↓) button, set this ON or OFF. If set to ON, the normal operating screen will scroll from % Capacity Remaining, which shows the percent capacity remaining in each tank, to Water Flow Rate. If there is a recharge scheduled, Recharge Tonight will also be displayed. Press the Menu/Exit (↵) button to set and return to the Primary menu. Move the cursor (→) to EXIT and press Menu/Exit button (↵) and return to the normal operating screen.

Set Rolling Display Screens OFF	↵ Exit
↑↓ Change	

REMOTE STATUS: This is a new optional feature for use. A remote monitor can be conveniently placed for viewing your conditioners status. This screen will show if the remote monitor setting has been turned on, and the status of the system (OK, check system). Note: “Low Salt” is not used on filters. Press the Menu/Exit (↵) button to set and return to the Primary menu. Move the cursor (→) to EXIT and press Menu/Exit button (↵) and return to the normal operating screen.

Remote: Installed Status: System OK	↵ Exit
--	--------

SEND SERVICE MESSAGE: Contact your installer for more information on service messages. This option may or may not be available. Press the Menu/Exit (↵) button and the controller automatically starts sending the service message in a series of beeps to be transmitted by phone. The display shows the how much of the message has been sent and a progress bar. To cancel the transmission press the Menu/Exit (↵) button. When message has been sent, the controller returns to the normal operating screen.

Sending Message	
56%	
■ ■ ■ ■ ■ □ □ □ □ □	↵ Exit

continued

FEATURES AND OPTIONS

ADVANCED SERVICE: By entering these menus, a warning screen will first be displayed. Only technicians or knowledgeable users should access these menus.

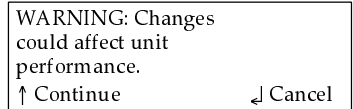

The following is a description of the features and options in the Advanced/Service Menu. To enter the Advanced/Service Menu, press the Menu/Exit (↵) button. Using the up (↑) or down (↓) button, move the cursor to Advance/Service and press the Menu/Exit (↵) button. The warning screen will show, press the up (↑) button to continue. To return to the Primary Menu, move the cursor (>) to EXIT and press Menu/Exit button (↵).

SET LANGUAGE: Using the up (↑) or down (↓) buttons, move the cursor (>) next to the preferred language. Press the Menu/Exit (↵) button to select and return to the Advance/Service Menu screen.



DIAGNOSTICS: This screen is for viewing only and will show any error codes plus information on each individual tank, depending on the configuration (simplex, duplex, etc.). Move the cursor (>) next to the specific tank and press the Menu/Exit (↵) button. Press the Recharge button and the valve will step through each cycle of the valve. Use the up (↑) or down (↓) buttons to view all lines of the screen. Press Menu/Exit button (↵) to return to the diagnostics screen.

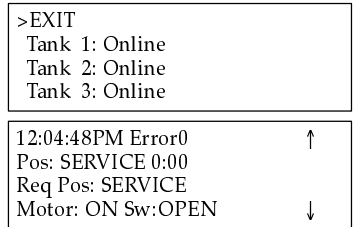

TEST REMOTE: At set up, the unit will send a signal to the remote every 3 seconds to allow for correct positioning of remote monitor. Press Menu/Exit (↵) to exit. Press the Menu/Exit (↵) button to return to the Advance/Service Menu screen. Note: This feature is not available if the optional remote is not installed in the controller.

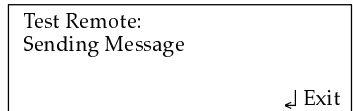

During normal operation, the green LED will flash at intervals of 5 seconds. The amber LED is only used for softeners; if the unit needs to be checked the red LED will flash.

The controller on the unit will send a signal to the remote monitor every minute. The remote monitor will listen for a signal every 10 minutes. Any changes in filter status could possibly take up to 10 minutes before the remote registers the change. If the unit stops sending a signal, the remote will keep trying to listen for the signal. If after 10 minutes with no signal received, the remote will try 1 minute later and 2 minutes later to find the signal, gradually increasing the time between, but will keep trying to listen for the signal for up to 2 days. After 20 minutes with no signal received, the remote monitor will turn off the LED's to conserve battery life, but will still be active. After 2 days with no signal received, the remote monitor will shut down until the reset button is pushed (on back of remote).

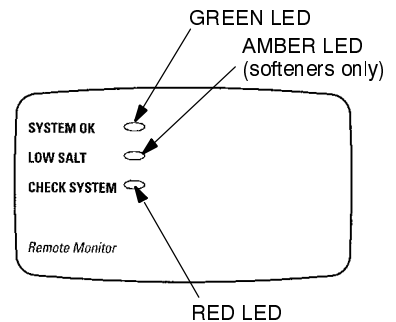

The remote uses 3 “AAA” batteries, which are included. To check batteries, press reset button on back of remote monitor. If batteries are good, the LED's on the remote should scroll green, amber, red. If LED's do not light, batteries need to be changed.

If there is another unit within range of the remote, it may cause a conflict with the channel that the remote monitor is receiving. If the remote monitor displays the wrong message (example: low salt when salt is above warning level) this is an indication that the remote monitor is receiving a different signal. Follow the steps below under SET REMOTE CHANNEL to change the remote channel.

NOTE: This device complies with Part 15 of the FCC Rules. Operation is subject to the following two conditions: (1) this device may not cause harmful interference, and (2) this device must accept any interference received, including interference that may cause undesired operation. Changes or modifications not expressly approved by the party responsible for compliance could void the user's authority to operate the equipment.

SET REMOTE CHANNEL: Press (↑) or (↓) to select a new channel from 1 to 16. Press the Menu/Exit (↵) button to select, and press reset button on back of remote monitor. Note: This feature is not available if a remote is not installed.



continued

FEATURES AND OPTIONS

SET MAX DAYS/RECHARGE: Press (↑) or (↓) to change Max Days Between Recharges. If Automatic is selected, the algorithm will determine when to recharge. If 1 to 15 is selected, the unit will never go past the number of days set for a recharge, but could recharge before. Press the Menu/Exit (↵) button to select and return to the Advanced/Service menu.

Set Max Days Between Recharges: Automatic ↑↓ Change	↵ Exit
---	--------

SET 97% FEATURE: (For use in European markets) Press (↑) or (↓) to set either OFF or ON. If ON is selected, the unit will automatically recharge when 97% capacity has been used, at any time of the day. Press the Menu/Exit (↵) button to select and return to the Advanced/Service menu. Note: This feature is available for single tank configurations only.

Set 97% Recharge Feature: OFF ↑↓ Change	↵ Exit
---	--------

SET CHLORINE/BYPASS: This feature is for European units. Press (↑) or (↓) to set on Bypass, Chlorine-Half Wave or Chlorine-Full Wave. Press the Menu/Exit (↵) button to select and return to the Advanced/Service menu.

Set Chlorine/ Bypass Bypass ↑↓ Change	↵ Exit
---	--------

VALVE CONFIGURATION: This option allows you to reprogram the controller. After all valve configuration selections have been made, all other settings (clock, water hardness, etc.) will need to be reset. Note: The controller will also reset all counts back to zero (number of recharges, etc.), except for the number of days in service.

Set Valve Type: One Inch Single Disc ↑↓ Change	↵ Next
--	--------

OPERATION

ELECTRONIC CONTROLLER AND WATER METER

The controller is actually a small computer. As it receives pulses from the water meter it converts them to gallons of water passing through the unit. It uses this information to continually calculate the capacity remaining.

When the computer determines more capacity is needed, at the next regeneration starting time (2:00 a.m., or as otherwise preset), it will schedule a regeneration. RECHARGE TONIGHT shows in the display to inform of the coming regeneration.

The water meter is located in the 1" valve outlet port. It consists of a turbine, turbine mounting assembly, and a sensor housing pickup (Figure 9). The turbine and sensor pickup are oriented in-line, centered in the water stream. Water flow turns the turbine, which houses two small magnets. As the turbine spins, the magnets cause the sensor pickup to switch back and forth. This switching sends an electrical pulse through the sensor leads, to the circuit board computer. The computer counts the pulses and converts them to gallons. The sensor is in a sealed chamber to keep out dirt, moisture and corrosion.

Figure 9

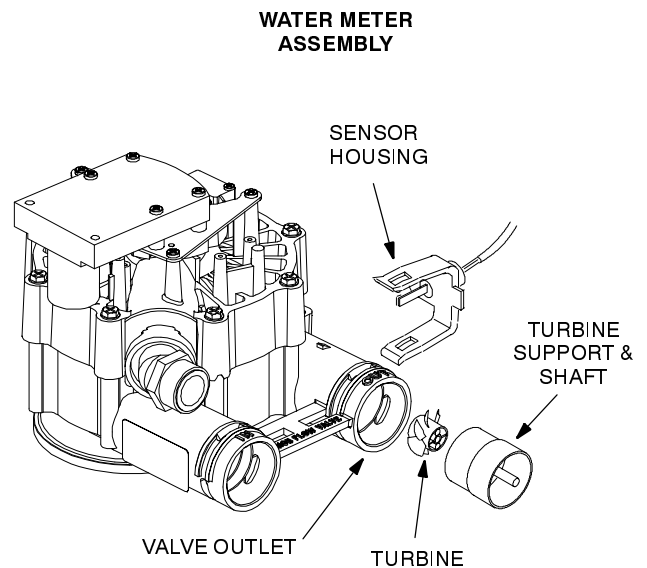

OPERATION – WATER FLOW THROUGH THE SYSTEM

The unit can be filled with several media, dependant on the application. The media have the ability to remove a variety of contaminants from water. The filter bed is supported by a layer of quartz gravel that fills the bottom of the tank and covers the bottom distributor.

SERVICE (Figure 10) : Raw water enters the unit, passes through the valve, and flows down into the mineral tank and filter bed. As it passes through the bed, contaminants are extracted from the water. Filtered water exits the filter bed through the bottom distributor, flows up the internal standpipe into the valve, then out to faucets or other points of usage.

After time, the filter bed holds all of the contaminants it can, and cleaning by backwashing is needed. Regeneration and recharge are words used to describe this cleaning.

SERVICE

Figure 10

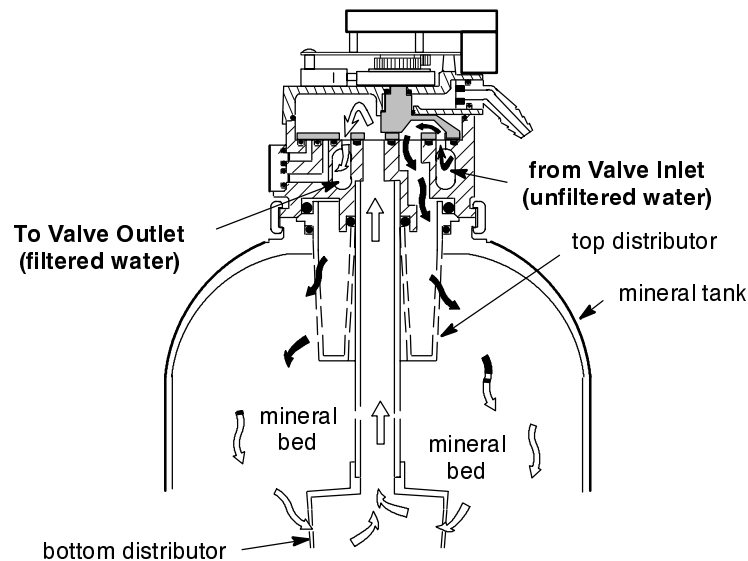

REGENERATION, or RECHARGE: The programmed faceplate timer starts regenerations at 12:00 AM, or other preset time. Regeneration consists of two steps, or cycles. These are **backwash** and **fast rinse**.

BYPASS RAW WATER: (Single configurations only) During the backwash and fast rinse cycles of regeneration, *raw* water is bypassed through the valve and is available if needed. You should **avoid using hot water**, if possible, because the water heater will refill with raw water.

continued, page 18

OPERATION – WATER FLOW THROUGH THE SYSTEM

BACKWASH

Figure 11

The motor drives the valve to backwash. In backwash, a fast upward flow of water through the filter bed flushes dirt, sediments, iron deposits, etc., from the bed and to the drain. The fast flow lifts and expands the filter bed for maximum cleaning.

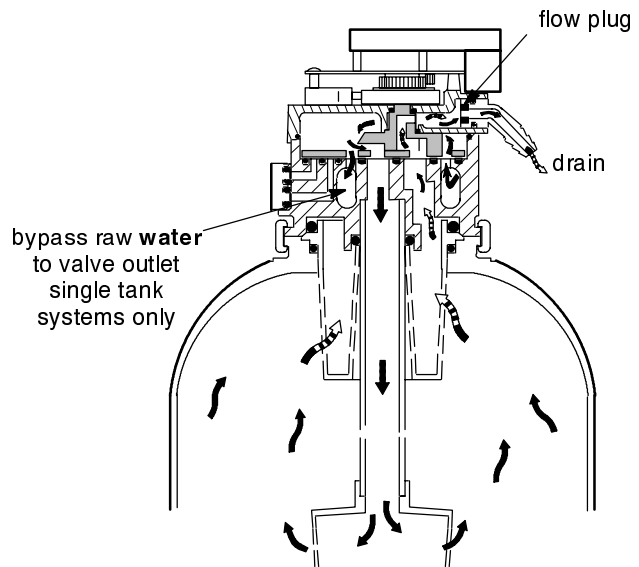

FAST RINSE

Figure 12

After backwash, valve rotation places the unit in fast rinse. A continued fast flow of water reverses direction, flowing down through the bed. The fast flow packs the filter bed in preparation for service.

The valve motor is energized a final time to drive the valve to service position.

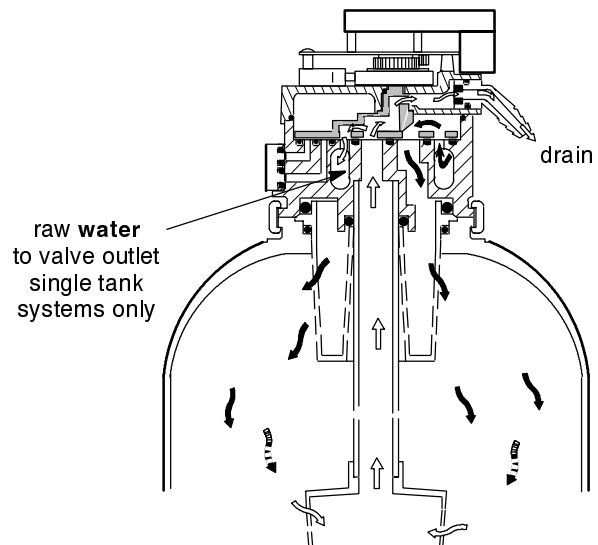

SERVICE INFORMATION

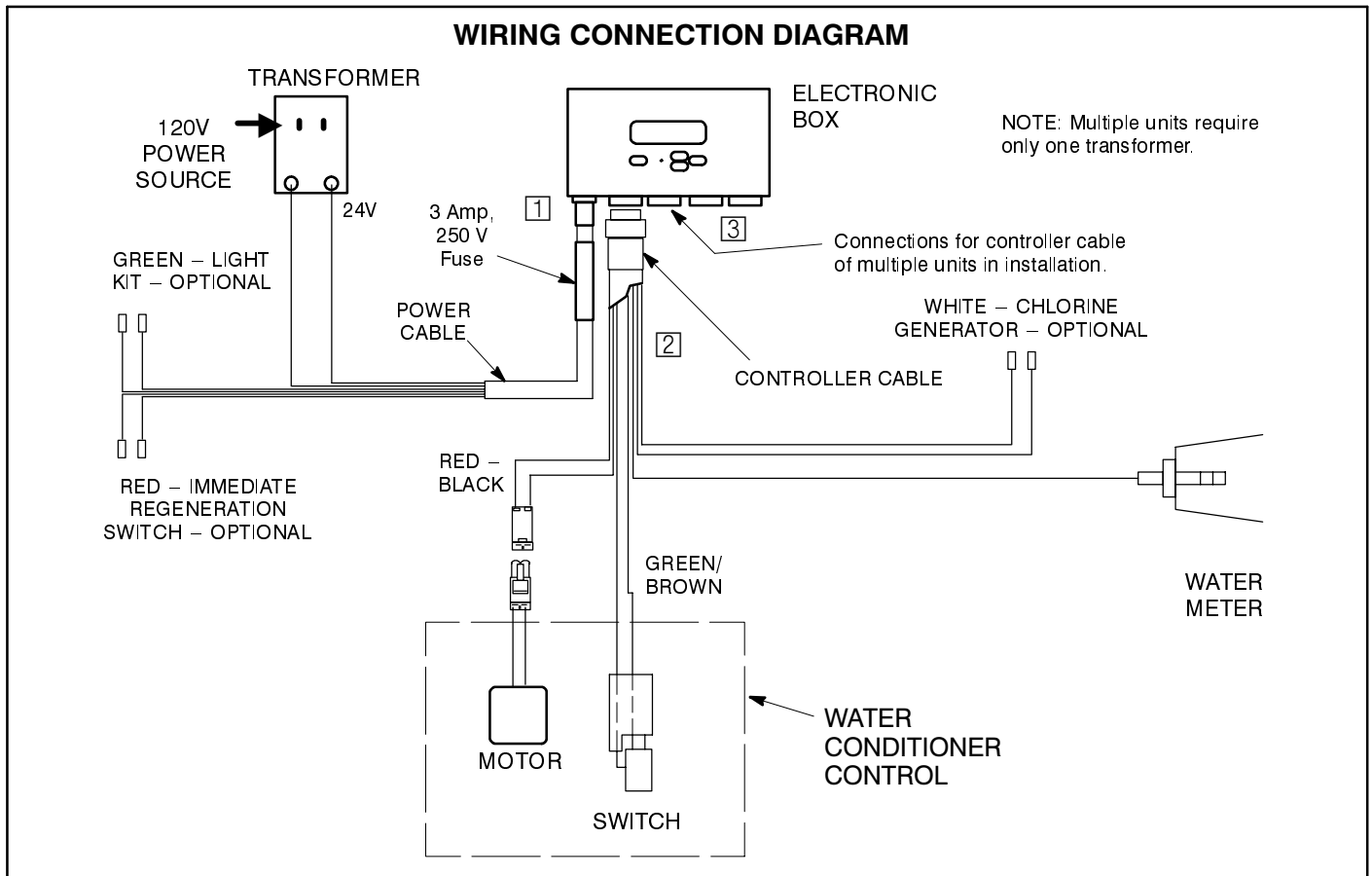

SERVICE INFORMATION

TROUBLESHOOTING

ALWAYS MAKE THE INITIAL CHECKS FIRST:

1. Does the time display show the correct time of day?
...If display is blank, check power source to the conditioner.
...If display is blank, check the fuse on the power cord.
...If time is flashing, power was off for longer than the built-in program memory. The filter resumes normal operation, when power returns, but regenerations occur at the wrong time.
...If an error code shows in the display (example: Error3), go to table on page 20.
2. Plumbing bypass valve(s) must be in service position (all the way open or closed, as applies. . . see page 10).
3. Inlet, outlet and drain must connect to the filter as shown on pages 8 & 9.
4. Is the transformer plugged into a “live” wall outlet, and the power cable fastened securely?

If you do not find a problem after making the initial checks, do **MANUAL ELECTRONIC DIAGNOSTICS**, and the **MANUAL ADVANCE REGENERATION CHECK**, page 21.

AUTOMATIC ELECTRONIC DIAGNOSTICS

The timer computer has a self-diagnostic function for the electrical system (except input power and water meter). The computer monitors electronic components and circuits for correct operation. If a malfunction occurs, an error code appears in the timer display area of the electronic box.

Error # 3
 Tank #1
 Recharge to Retry
↵ Menu

The chart below shows the error codes that could appear, and the possible defects for each code.

While an error code appears in the display, the tank is taken offline and either the Recharge button or Menu/Exit (↵) can be used. Menu/Exit (↵) remains operational so the service person can make the Manual Electronic Diagnostics to further isolate the defect, and check the water meter.

If Recharge is pressed, the display will show the diagnostics screen and cycle the valve through all positions to try to correct the error itself. After it is done retrying, the display reverts back to the run screen (either showing error code again or normal run screens).

If the controller successfully fixes the problem in the diagnostics display, the unit automatically is placed back online by the software. There would be no need to go into the online/offline screen to put the unit back online.

PROBLEM	POSSIBLE DEFECT	POSSIBLE SOLUTION
No display.	No power to outlet.	Check the outlet by plugging in another appliance.
	Fuse blown.	Check fuse in power cable. REPLACE WITH SAME TYPE AND VALUE: AGC 3A 250V.
	Internal transformer fuse blown.	Plug the transformer into an outlet and measure output voltage with a multi-meter. Should be between 24 and 30 volts AC.
Fuse keeps blowing.	Wiring harness shorted or not connected properly.	Check connections at controller box and valve. Connect all other wires before plugging transformer into outlet.
Error code 1, 3 or 4.	Wiring harness not connected or broken wire.	Check connections at controller box and valve. Check for corrosion at connection points.
	Incorrect position switch connections.	Check valve switch connections.
	Incorrect valve type selected on new install or upgrade to system.	Check proper valve configuration is selected controller box.
	Valve motor running slow, or not at all.	Initiate a recharge and step valve through all positions. Check motor for consistent movement. If slow, check motor and valve seals.
Error code 6	Optional immediate regeneration switch is stuck in the on position.	Check red wires from power cable for possible shorts, check optional immediate regeneration switch.

Procedure for removing error code from faceplate: Press the RECHARGE button, or: **1.** Unplug transformer---- **2.** Correct defect---- **3.** Plug in transformer---- **4.** Wait for 6 minutes. The error code will return if the defect was not corrected.

MANUAL ELECTRONIC DIAGNOSTICS

1. Do the preceding (page 19) INITIAL CHECKS first.
2. Enter the diagnostics screen on the controller (page 20) and using the down (↓) button, view the turbine information.

Pos: SERVICE 0:00	↑
Req Pos: SERVICE	
Motor: ON Sw: OPEN	
Trbn: 000 Gals: 0	↓

The 3 digits after “Trbn:” indicate water meter operation as follows.

000 (steady) = filtered water not in use...no flow through the meter.

- open a nearby filtered water faucet -

000 to 140 (continual) = repeats display for each gallon of water passing through the meter.

If you don't get a reading in the display, check the turbine connection to the electronic box. If the connection is okay and good contact is made, pull the sensor from the valve outlet port. Pass a small magnet back and forth in front of the sensor. You should get a reading in the display. If you get a reading, unhook the in and out plumbing and check the turbine for binding.

NOTE: *The position switch is closed when the plunger is depressed, open when extended.*

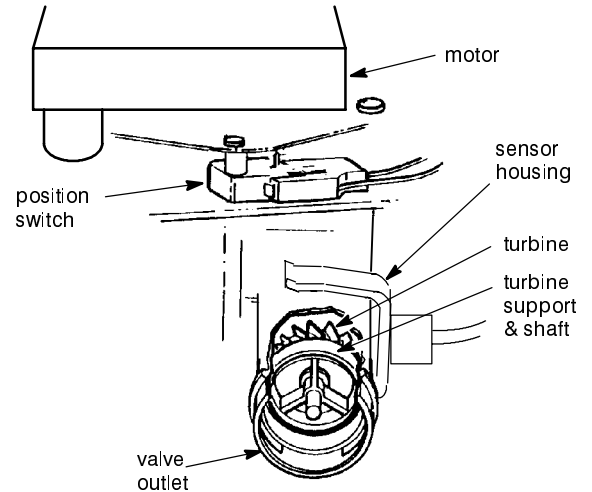

MAINTENANCE

TROUBLESHOOTING, MANUAL ADVANCE REGENERATION CHECK

This check verifies proper operation of the gear-motor, regeneration flow rates, and other controller functions. *Always make the initial checks, and the manual initiated diagnostics first.*

NOTE: A steady time (not flashing) must show in the display.

1. Use the recharge button to manually advance the valve into each cycle and check the various valve cycles. Move the cursor to Recharge Now and press Menu/Exit (↵). Move the cursor next to the appropriate tank and press the Recharge button. The valve will start the sequence for recharge. Press the Recharge button to advance the valve through each position.

>EXIT
Online/Offline
Recharge Now
Recharge Tonight

BACKWASH: Look for a fast flow of water from the drain.

- a. If flow is slow, check for a plugged internal riser pipe, backwash flow controls, drain piping, fouled filter bed, etc.

FAST RINSE: Again look for a fast drain flow.

2. To return the valve to service position, press Recharge button once again.

Note: On multiple tank systems, the first tank advances to service before the second tank then manually advances to regeneration cycle.

OTHER SERVICE

HARD WATER BYPASS (raw water “bleeds” into filtered water supply).

1. Defective disc, seal or wave washer (see key nos. 14, 15 and 32, page 24).
2. Missing or defective o-ring(s) at resin tank to valve connection (see key no. 9 or 12, page 22).

WATER RUNNING TO DRAIN IN SERVICE POSITION.

1. Defective disc, seal or wave washer.

REPAIR PARTS . . . RESIN TANK ASSEMBLIES

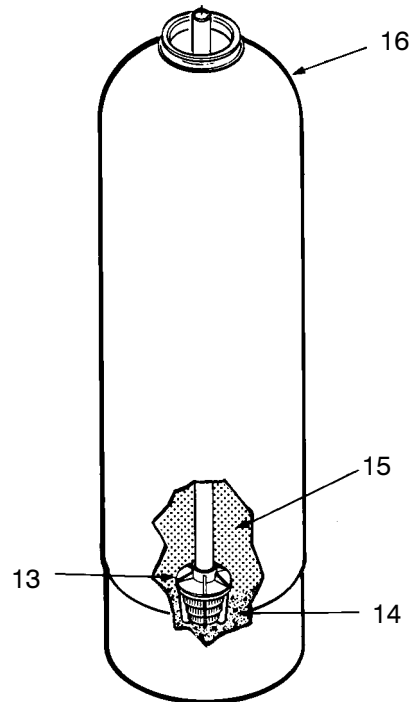
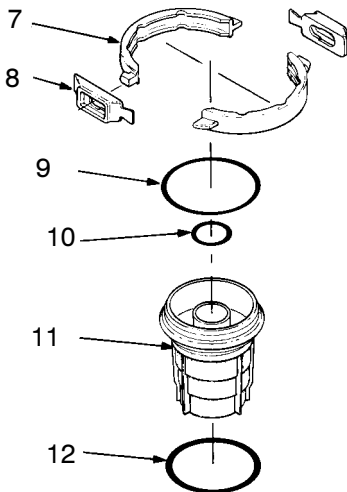
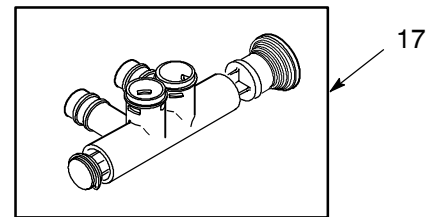
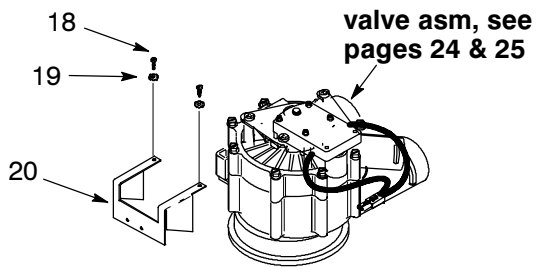
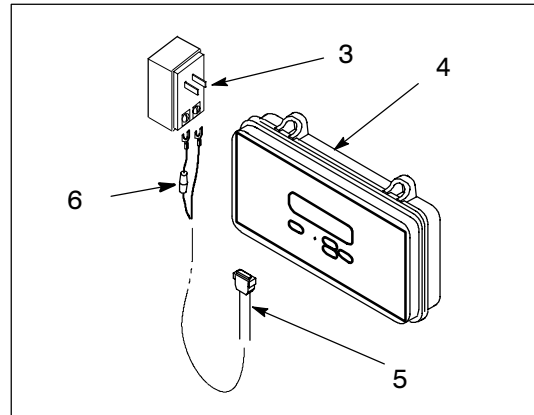
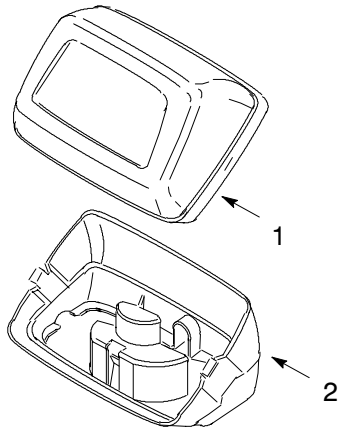

REPAIR PARTS . . . RESIN TANK ASSEMBLIES

KEY NO.	PART NO.	DESCRIPTION
1	7174868	Cover
–	7255818	Decal, Cover
2	7189449	Cover, Bottom
3	7085297	Transformer, 24V – 25 VA
4	7239854	Control Box
5	7234846	Power Cable
6	–	Fuse, AGC 3A 250V, Purchase locally, replace with same type and value only. 
7	7176292	Clamp Section (2 req'd)
8	7088033	Clamp Retainer (2 req'd)
9	7133529	O–Ring, 2–7/8" I.D. x 3–1/4"
10	7133480	O–Ring, 13/16" I.D. x 1–1/16"
11	7088855	Top Distributor
12	7133503	O–Ring, 2–3/4" I.D. x 3"
13	7127895	Rep'l Distributor (bottom) ^①
14	7124415	Gravel, Fine – 17 lbs. ^②
–	7124423	Gravel, Fine – 50 lbs. ^②
15	0993080	Filter Sand – 50 lb. bag ^②
–	3424509	Activated Carbon – 42 lbs/ft ³ ^②
–	0501676	Manganese Greensand – 85 lbs/ft ³ ^②
–	0993070	Anthracite – 50 lbs/ft ³ ^②
–	0993090	Garnet – 50 lb. bag ^②
16	7172638	Resin Tank (12" Dia. x 54") Models 121XS, 121CS, 121MS, 121GS
–	7172646	Resin Tank (17" Dia. x 58") Models 171XS, 171CS
17	7195408	Bypass Valve

Optional (Included with some models)

18	7103972	Screw (2 req'd)
19	0811297	Lockwasher (2 req'd)
20	7246047	Bracket

ACCESSORIES

–	7242996	Remote Monitor
–	7238735	Error Indicator
–	7238727	Controller Extension Cable, 20'

^① Be sure to check length...page 5.

^② See page 4 for amount required.

REPAIR PARTS ... VALVE ASSEMBLY

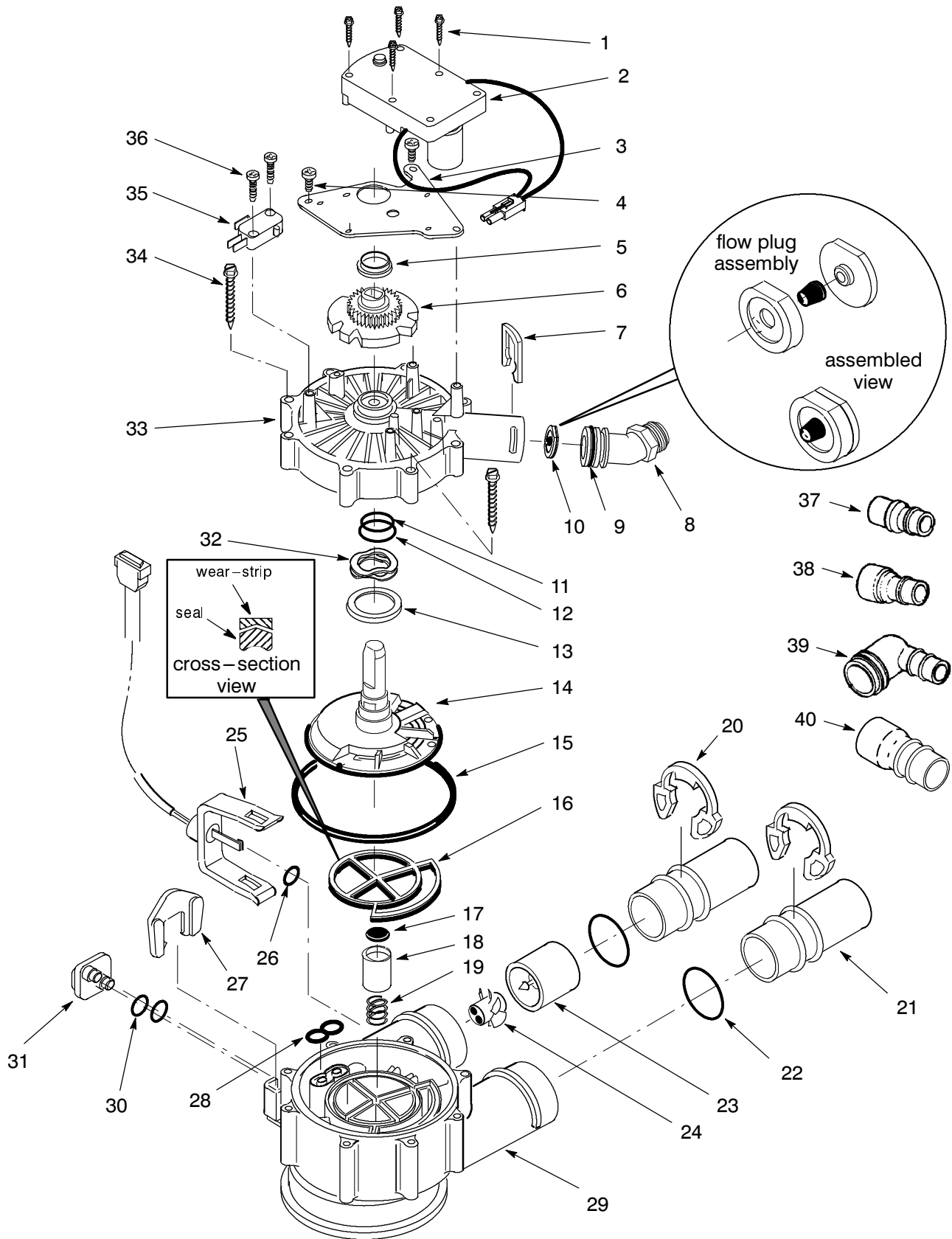

REPAIR PARTS . . . VALVE ASSEMBLY

KEY NO.	PART NUMBER	DESCRIPTION
1	7224087	Screw, #8-32 x 1 (4 req.)
2	7228544	Motor (incl. 4 ea. of Key No. 1)
3	7231393	Motor Plate
4	0900857	Screw, #6-20 x 3/8 (3 req.)
5	7171250	Bearing
6	7186386	Cam and Gear
7	7169180	Clip (Drain)
8	7172793	Drain Hose Adaptor
9	7170288	O-ring, 15/16 x 1-3/16
10	▼	Flow Plug
-	7178202	Models 121XS, 121CS (7.0)
-	7178210	Models 121GS, 121MS (10.0)
-	7178228	Models 171XS, 171CS (15.0)
11	-	O-ring, 5/8 x 13/16 ◆
12	-	O-ring, 1-1/8 x 1-1/2 ◆
13	7174313	Bearing, Wave Washer
14	7185500	Rotor & Disc, Single Tank Units
-	7229590	Rotor & Disc, Multiple Tank Units
15	-	O-ring, 4-1/2 x 4-7/8 ◆
16	-	Rotor Seal ◆
17	-	Seal ◆
18	7171187	Plug (Drain Seal)
19	7129889	Spring
20	7089306	Clip (2 req.)

KEY NO.	PART NUMBER	DESCRIPTION
21	7077642	Copper Tube, 1" (2 req.)
22	7170262	O-ring, 1-1/8 x 1-3/8 (2 req.)
23	7119177	Turbine Support
24	7123061	Turbine
25	7234854	Controller Cable & Sensor Housing Asm
26	0900060	O-ring
27	7081201	Retainer (Nozzle & Venturi)
28	-	Seal (Nozzle & Venturi) ◆
29	7171145	Valve Body
30	7170319	O-ring, 1/4 x 3/8 (2 req.)
31	7100940	Plug
32	7175199	Wave Washer
33	7223900	Valve Cover
34	7172997	Screw, #10 x 2-5/8 (8 req.)
35	7145186	Switch
36	7140738	Screw, #4-24 x 3/4 (2 req.)
◆	7185487	Seal Kit (incl. Key Nos. 11, 12, 15, 16, 17 and 28)

OPTIONAL INLET/OUTLET FITTINGS		
37	7104546	CPVC Nipple, Use in place of included copper inlet & outlet tubes.
38	7129211	1-1/2" Adaptor Fitting, Use in place of included copper inlet & outlet tubes.
39	7120259	Elbow, Extends inlet and/or outlet in any 90° direction.
40	7234553	1-1/4" Copper Tube, Use in place of included copper inlet & outlet tubes.

+ Multiple Tank Systems use special rotor & discs to prevent the use of unfiltered water during recharge. The illustrations below show the different rotors for identification.

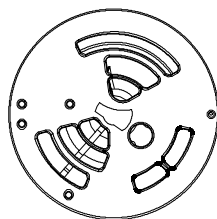

Rotor & Disc,
Single Tanks

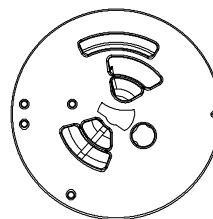

Rotor & Disc,
Multiple Tanks