

ECOWATER
S Y S T E M S®



P/N: 7243691
(Rev. F 6/9/04)

SHIPMENT INSPECTION

Thoroughly check the commercial system for possible shipping damage and/or parts loss. Also inspect and note any damage to shipping cartons, crating, etc. If damage is present, notify the transportation company. The manufacturer is not responsible for damage or parts loss in shipment.

Note: Do not mistakenly discard small parts bags when unpacking the system.

All models are shipped in 3 cartons; (1) resin tank, (2) brine tank, and (3) controller. The mineral bed consists of 1 cubic foot bags of water softening resin, and 17 or 50 pound bags of various grades of gravel. Refer to the following chart.

MODEL		EWS050	EWS070	EWS100	EWS130	EWS190	EWS250	EWS320
1 CU. FT. BAGS OF RESIN		1-1/2	2	3	4	6	8	10
BAGS OF GRAVEL (LBS)	fine	1 (17)	1 (17)	2 (17)	2 (17)	1 (50)	1 (50)	1 (50)
	medium					1 (50)	1 (50)	1 (50)
	coarse					1 (50)	1 (50)	1 (50)

SAFETY GUIDES

Follow the installation instructions carefully. Failure to install the commercial system properly voids the warranty.

Before you begin installation, read this entire manual. Then, obtain all the materials and tools you will need to make the installation.

Check local plumbing and electrical codes. The installation must conform to them.

Use only lead-free solder and flux for all sweat-solder connections, as required by state and federal codes.

Do not locate the system where freezing temperatures occur. Do not attempt to treat water over 120°F. **Freezing, or hot water damage voids the warranty.**

Avoid installing in direct sunlight. **Excessive sun heat may cause distortion or other damage** to non-metallic parts.

The system requires a minimum water pressure of 30 psi at the inlet. **MAXIMUM ALLOWABLE Inlet water pressure is 125 psi.** If daytime pressure is over 80 psi, nighttime pressure may exceed the maximum. Use a pressure reducing valve if necessary. (Adding a pressure reducing valve may reduce the flow.)

The system works on 24 volt-60 Hz electrical power only. Be sure to use the included transformer.

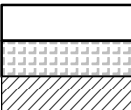

TABLE OF CONTENTS

	Page No.
Specifications	4
Dimensions	5
Resin Loading and Assembly	6-7
Planning Installation	7-8
Installation Steps	
Inlet - Outlet Plumbing Drawing	8
Notes and Cautions	9
Connecting Brine Tank	9
Connect Valve Drain Hose	10
Pressure Testing	11
Filling Brine Tank with Water and Salt	11
Programming the Controller at Start-up	12
Programming the Controller - Softeners	12-14
Programming the Controller - Filters	14
Features and Options	15-18
FCC Information	17
Operation	
Controller and Water Meter	19
Water Flow Through the System	19-22
Service Information	
Salt, Recommended Type and Refilling	23
Removing a Salt Bridge	23
Cleaning the Nozzle-Venturi	23-24
Cycle Time - Flow Rate Chart	24
Electronic Demand Controller	
Wiring Schematic	25
E.A.S.E	25
Troubleshooting	26-30
Error Code Table	27
Repair Parts	
Resin Tanks / Distributor	31
Valve Assembly	32-33
Brine Tanks and Brine Valves	34-37
Controller and Associated Parts	38
No-Bypass Kit Installation	39

SPECIFICATIONS

	MODEL						
	EWS050	EWS070	EWS100	EWS130	EWS190	EWS250	EWS320
CAPACITY (GRAINS) @ SALT USAGE	23200 @4.5 lbs	31000 @6.0 lbs	45000 @9.0 lbs	60000 @12.0 lbs	90000 @18.0 lbs	123000 @24.0 lbs	153800 @30.0 lbs
	37300 @8.3 lbs	49700 @11.0 lbs	69000 @15.3 lbs	95000 @21.6 lbs	141000 @32.0 lbs	182500 @40.0 lbs	227900 @49.0 lbs
	51400 @15.3 lbs	68500 @20.4 lbs	93000 @25.0 lbs	130000 @38.0 lbs	192000 @55.0 lbs	242000 @64.0 lbs	302000 @75.0 lbs
AMOUNT OF RESIN ^① (cu. ft)	1.5	2	3	4	6	8	10
SALT STORAGE CAPACITY (lbs)	400	400	700	700	1500	1500	1500
RECOMMENDED FLOW RATES ^②	WATER PRESSURE LOSS (psi)						
	5 GPM	2.2 ΔP	2.6 ΔP	1.3 ΔP	1.4 ΔP	1.2 ΔP	1.2 ΔP
	10 GPM	5.6 ΔP	6.6 ΔP	3.8 ΔP	4.0 ΔP	3.1 ΔP	3.3 ΔP
	15 GPM	10.4 ΔP	11.8 ΔP	7.3 ΔP	7.8 ΔP	6.3 ΔP	6.6 ΔP
	20 GPM	16.3 ΔP	18.3 ΔP	11.8 ΔP	12.7 ΔP	10.5 ΔP	10.9 ΔP
	25 GPM	23.1 ΔP	26.0 ΔP	17.4 ΔP	18.6 ΔP	16.3 ΔP	16.8 ΔP
	30 GPM	31.1 ΔP	34.8 ΔP	24.1 ΔP	25.7 ΔP	21.9 ΔP	22.6 ΔP
	35 GPM	38.1 ΔP	42.8 ΔP	31.8 ΔP	33.7 ΔP	29.1 ΔP	30.0 ΔP
40 GPM	46.1 ΔP	51.8 ΔP	39.8 ΔP	42.7 ΔP	37.3 ΔP	38.4 ΔP	
WATER SUPPLY PRESSURE RANGE (psi)	30 — 125						
WATER SUPPLY TEMPERATURE RANGE (°F)	35 — 100						
WATER SUPPLY MAXIMUM "CLEAR WATER IRON" (ppm)	5						
ELECTRICAL RATING	24V — 60Hz						

① synthetic high capacity resin

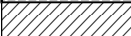
② psi pressure loss @  continuous flow rates
 intermittent or peak flow rates
 flow rates not recommended (hardness leakage, reduced efficiency, etc.)

PROGRAMMING INFORMATION							
RESIN QUANTITY (CU. FT.) ^③	1.50	2	3	4	6	8	10
REFILL RATE (GPM)	0.3	0.3	0.3	0.3	0.5	0.5	0.5
TURBINE SIZE (IN)	1"	1"	1"	1"	1"	1"	1"
BACKWASH TIME (MIN)	20	20	12	12	14	14	14
FAST RINSE TIME (MIN)	5	5	5	5	10	10	10
BRINE TIME (MIN) @ SALT DOSE (LBS)	LBS	MINUTES					
	4, Auto Adj. or Salt Eff.	108	144	115	160	150	160
	6	97	129	110	150	145	150
	8	86	114	105	145	135	145
	10	74	99	100	135	130	135
	12	63	84	95	130	125	130

③ synthetic high capacity resin

DIMENSIONS

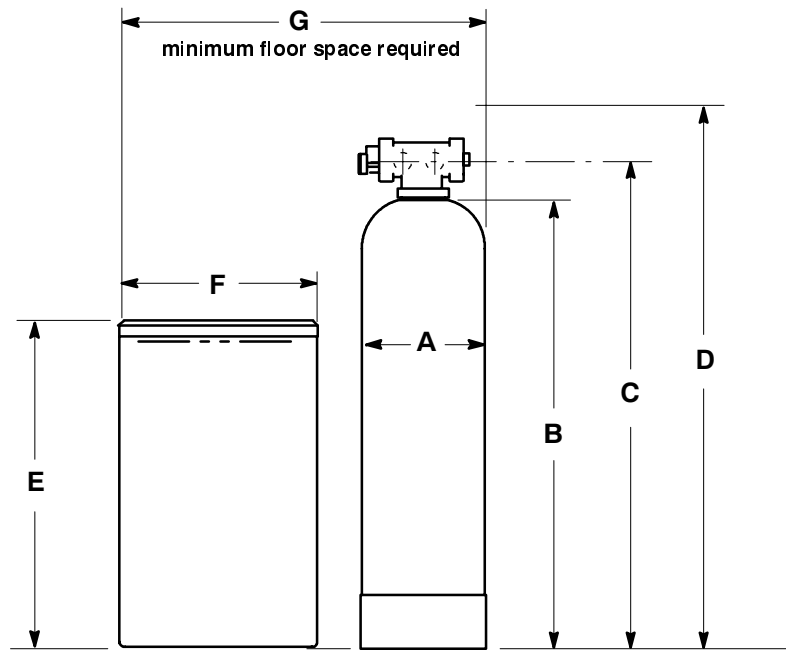

ROUND BRINE TANK

MODEL	A Resin Tank Diameter	B Resin Tank Height	C Inlet-Outlet Height	D Overall Height	E Brine Tank Height	F Brine Tank Diameter	G ¹	INLET-OUTLET	
								Pipe Size	Pipe Center lines
EWS050 EWS070	12.3"	55"	58"	63.75"	39"	17"	35.3"	1"	3.8"
EWS100 EWS130	17.6"	59.5"	62.5"	68.25"	41"	24"	48"	1"	3.8"
EWS190 EWS250 EWS320	24"	76"	79.8"	85.5"	51"	30"	60"	1"	3.8"

¹ Includes 6" between tanks.

RESIN LOADING AND ASSEMBLY

1. Move the resin tank into installation location (see page 7). Set it on a flat, level surface. If a multiple installation, keep tanks separated for ease of service.

2. Remove the shipping cap, top distributor and o-rings. On **all models**, place the *bottom* distributor into the resin tank. Check the distributor length as shown in Figure 1, and adjust if needed. Center the distributor in the tank.

3. With a pail or hose, fill the tank with 1 to 2 feet of water. The water acts as a cushion to protect the bottom distributor while filling the tank with gravel and resin.

4. Plug the end of the distributor tube with a clean rag, to keep gravel and resin out.

5. Using a larger neck funnel, add the specified (see pages 2 and 24) amount of gravel. **Be sure the distributor remains centered.**

Note: When coarse, medium and fine gravels are specified, add in that order.

6. Add the specified amount of resin, using water sparingly to speed flow through the funnel.

7. Flush the tank opening with water to clean resin beads from the top of the tank. Then, remove the rag from the distributor tube.

8. Finish filling the tank with water, up to the top of the tank.

Important: Be sure to fill with water. This will eliminate air space and prevent excessive air-head pressure when the water conditioner is pressurized.

9. Install the o-ring seals and top distributor exactly as shown in Figure 2. If the o-rings need lubrication, use a high quality silicone grease.

Figure 1

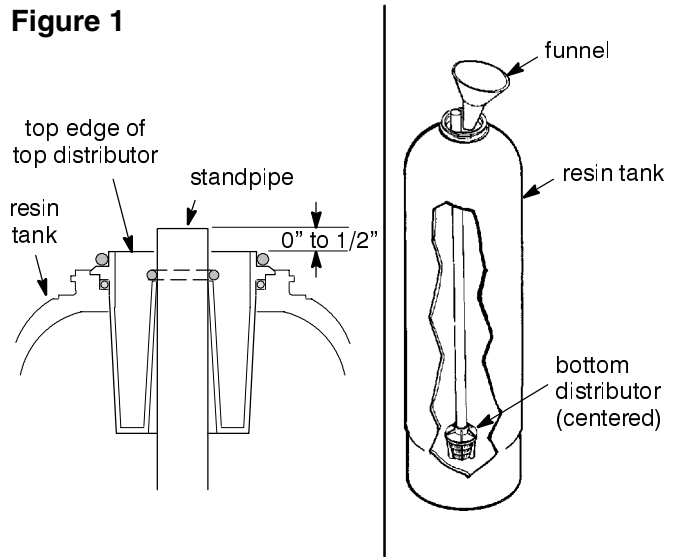
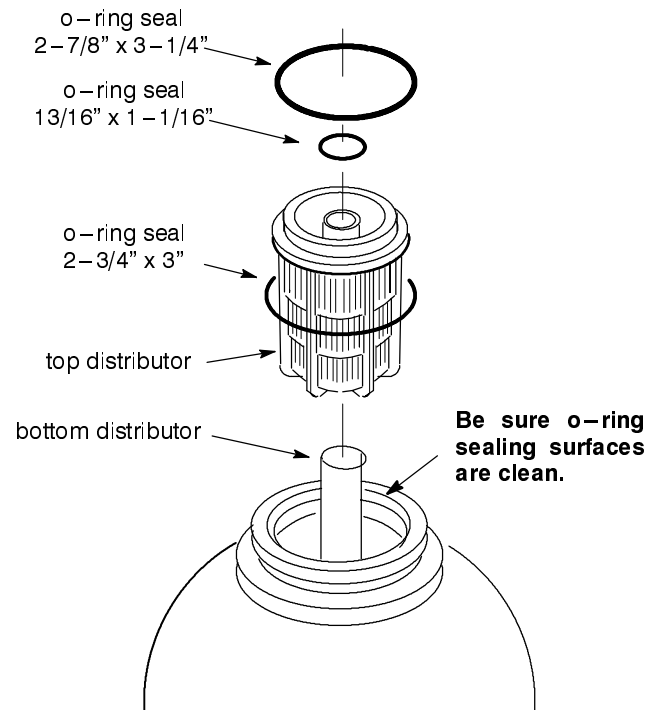

Figure 2



Note: Resin tank height can vary somewhat within manufacturing tolerance. **So the bottom distributor riser pipe has proper clearance with inside valve porting, check for the correct length as shown above.** Cut the riser if needed to adjust the length. Be sure to remove burrs and sharp edges.

continued

RESIN LOADING AND ASSEMBLY

Important: Check the valve outlet to be sure the turbine and turbine support are securely in place.

10. Lower the valve assembly onto the resin tank, centering over the bottom distributor tube. Push downward, against the o-ring, and install the clamp sections, securing with the retainers.

Figure 3

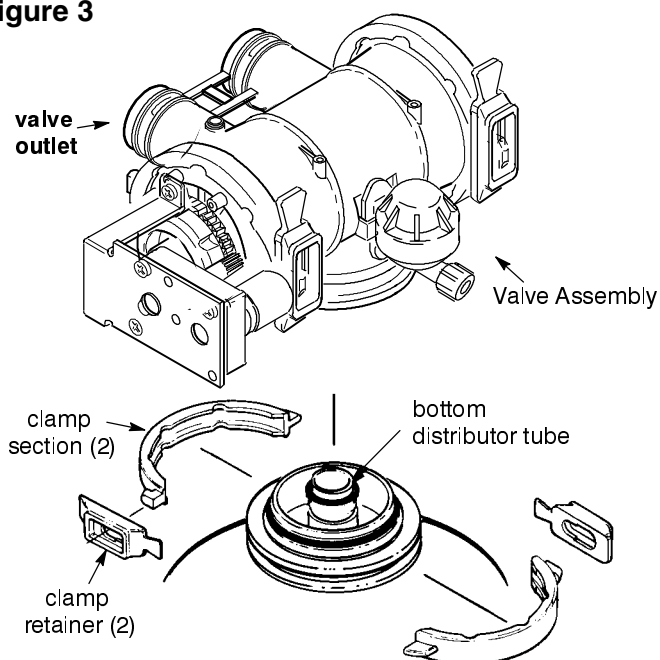

PLANS FOR LOCATION AND INSTALLATION OF SYSTEM

WATER SUPPLY: The system requires a potable water supply that will provide a continuous flow to meet regeneration flow specifications. A minimum pressure of 30 psi is required at the conditioner inlet.

“FULL LINE” (both hot and cold water) WATER CONDITIONING: Connect the system to the water supply pipe, immediately *after* (downstream) the municipal supply water meter or well supply pressure tank.

CONDITIONING HOT WATER ONLY: Connect the system to the water supply pipe, immediately *before* (upstream) the water heater.

CAUTIONS: (1) **Do not install** the conditioner *after*, or downstream from **the water heater**. **Hot water will damage** inner parts of the system and may cause the loss of the water softening resin bed. (2) **To reduce the risk of hot water flowing backwards**, into the conditioner, piping between the conditioner and water heater should be as long as possible.

DRAIN: A drain is needed nearby the conditioner, capable of carrying away backwash water at the rate of flow listed in the specifications. A floor drain is preferred. Other approved drain points are acceptable, if they do not cause a back-pressure on the conditioner drain hose or pipe.

ELECTRICAL: The system works on **24 volts only**. A transformer is included to reduce 120V-60Hz electrical power. An approved, grounded outlet is needed within 10' of the conditioner controller for the transformer. The conditioner includes a 10' power cable to connect between the transformer and the controller. The controller may be mounted in any convenient location. You may either fasten to a wall using the mounting holes molded in the controller case, or hang on the valve with the included brackets.

SPACE REQUIREMENTS: Be sure to allow sufficient area around the resin and brine tanks for refilling with salt and other service. Minimum floor space and other dimensions are shown on page 5.

MATERIALS YOU MAY NEED

Use the drawing below as a guide for your installation. The drawing shows typical connection using fittings included with the unit, and with optional items available.

■ Be sure to install a 3-valve bypass system, or use the **optional bypass valve, #7195408**. Bypass valves allow you to turn off water to the system for servicing, while having full-line bypass to the establishment.

■ A **5/8" minimum** inside diameter hose or pipe is required for the valve drain (see page 10). The drain fitting has standard garden hose threads, and hose barbs. Adaptors are available from most hardware stores to convert the fitting to accept rigid pipe. A garden hose is also needed for the drain on brine tanks.

■ For in and out pipes to the conditioner, use copper, CPVC plastic or threaded pipe and fittings. Avoid joining copper and galvanized together as corrosion will occur rapidly. Included inlet and outlet adaptors are 1" male copper. Optional fittings available are shown in Figure 5.

■ **Multiple Unit Installations:** To promote equal water flow, inlet and outlet plumbing configuration to each valve should be as identical as possible. Use the same fittings and pipe lengths for each connection. See Figure 4.

Note: To eliminate hard water bypass from a regenerating unit, order "No Bypass Kit" #7128825.

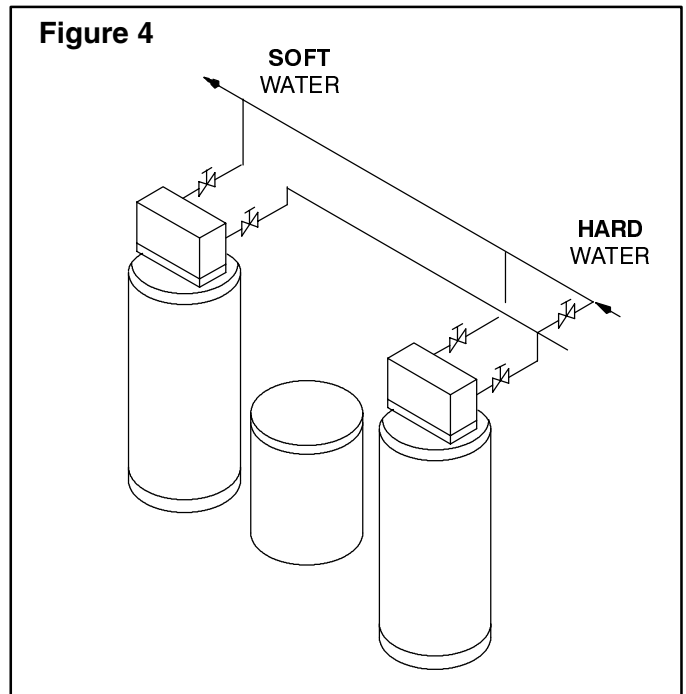

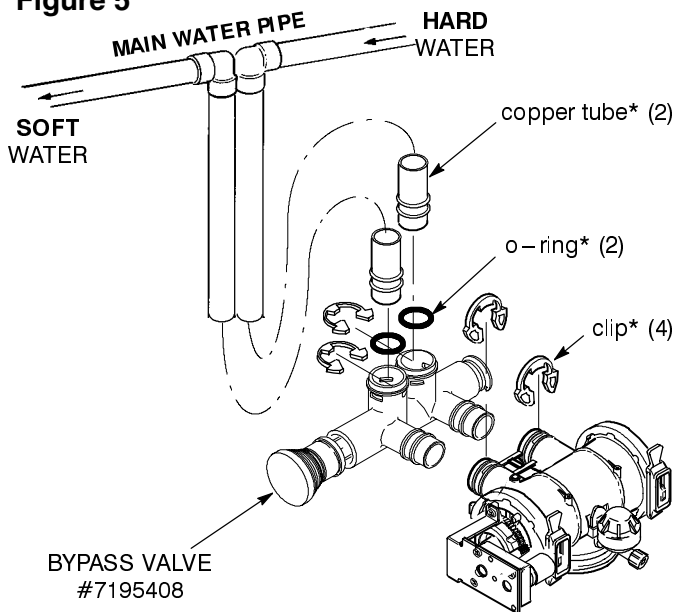

TYPICAL INLET- OUTLET PLUMBING CONNECTIONS

Figure 5



*included with conditioner

OPTIONAL INLET/OUTLET FITTINGS

-  — #7104546 PVC Nipple — Use in place of included copper inlet and outlet tubes.
-  — #7129211 Adaptor Fitting, 1-1/2" (2) — Use in place of included copper inlet and outlet tubes.
-  — #7120259 Elbow — Extends inlet and/or outlet in any 90° direction.

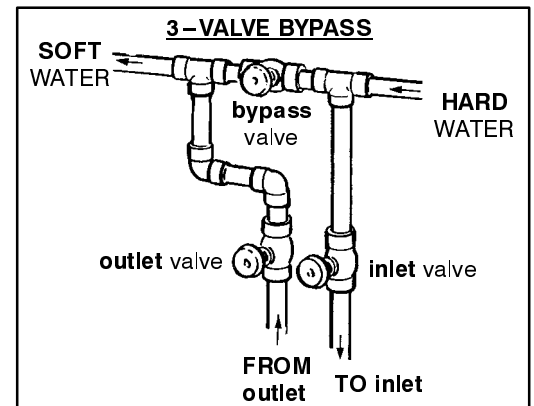

INSTALLATION STEPS

PIPING ASSEMBLY NOTES AND CAUTIONS:

- BE SURE to **close the main water supply valve** before beginning.
- BE SURE to plumb so **hard water flows to the valve inlet** fitting.
- **CAUTION:** When soldering, make sub-assemblies as needed to **prevent soldering heat damage** to the conditioner valve or bypass valve. Be sure soldered piping has cooled before connecting to the conditioner.
- Use Teflon tape or pipe joint compound on external pipe threads.
- Lubricate o-ring seals with high quality silicone grease.

1. Looking at the illustrations on page 8, and observing the notes above, run piping from the main **water supply** pipe **to the valve inlet**. Then, run return piping from the valve outlet to the supply pipe. Be sure to include a 3-valve bypass, or use one of the optional bypass valves.

Note: When working with soldered copper, be sure to observe the caution above to avoid damage to non-metallic parts.

Important: Support in and out piping in an acceptable manner, to prevent weight stress on the conditioner valve.

2. Move the brine tank assembly into position nearby the resin tank. Enough tubing is included to allow locating the brine tank up to either 6' or 10' away from the resin tank (Figure 6).

3a. Connect Tubing - Models EWS050 & EWS070: Thread the brine tube through the hole of the brine tank sidewall. Fasten tubing to the nozzle assembly (Figure 6) using the compression nut-ferrule, tightening securely, by hand only.

3b. Connect Tubing - All other models:

- 1 Turn two elbows (in separate parts bag with the brine tank) into the top and bottom of the nozzle assembly (Figure 6).
- 2 Using tubing inserts and compression nuts, fasten lengths of tubing to the two elbows.
- 3 Connect tubing from the **bottom of the nozzle assembly, to the top adaptor** on the front of the conditioner valve assembly. Use a tubing insert and compression nut (tighten securely) as shown in the inset drawing.
- 4 Do the same to connect tubing from the top of the nozzle, to the bottom check valve fitting on the front of the conditioner valve assembly.

4. Install the rubber grommet and hose adaptor elbow, in the open hole, in the tank sidewall. Push the elbow fitting, with garden hose threads on one end, into the hole in the sidewall of a round brine tank. Attach a length of drain hose to the fitting as follows.

continued

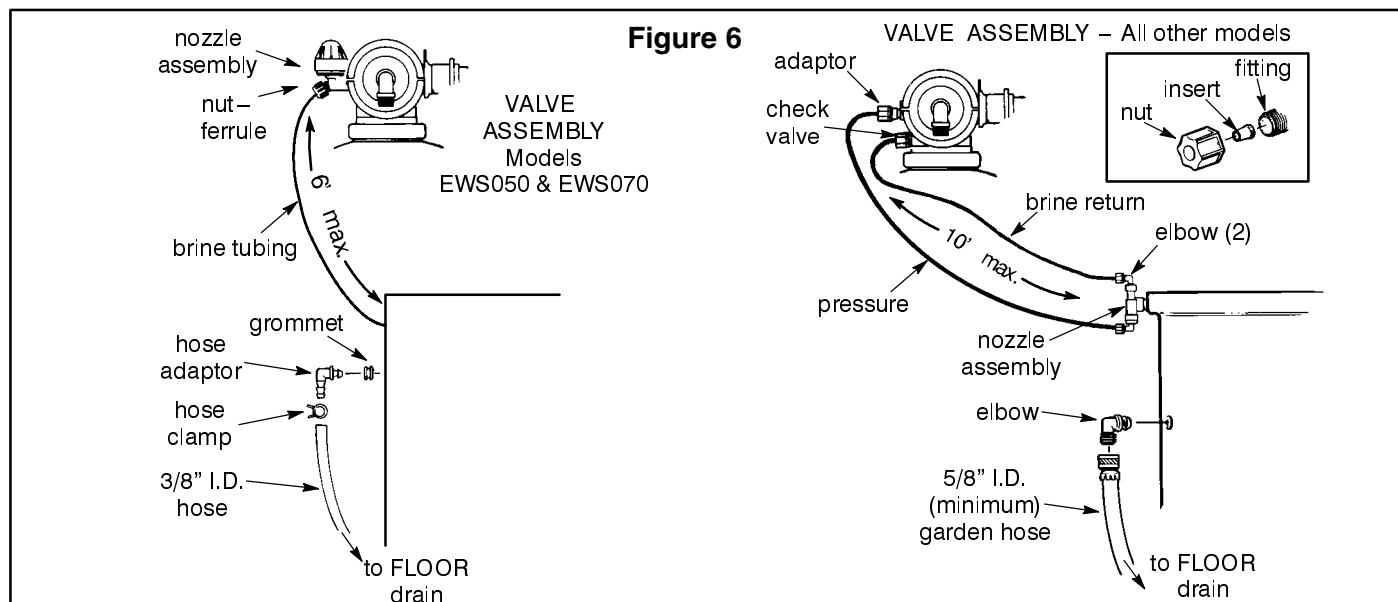

INSTALLATION STEPS

1 Models EWS050 & EWS070: Use a length of high quality, 3/8" I.D. hose, and attach to the hose adaptor elbow. Place the other end of the hose over the floor drain.

2 All other models: Attach a length of 5/8" I.D. garden hose to the elbow and run to the floor drain.

Important: This *gravity* drain is a safeguard to carry away excess water if the brine tank should overflow.

6. Install Valve Drain Hose: The drain fitting accepts a **5/8" I.D. minimum** drain hose, either garden hose connection, or hose onto a barb fitting (Figure 7). To use the garden hose threads, cut the barbed section of the elbow off with a hack-saw.

Note: See the service information charts on page 24 for flow washer identification.

Attach the drain hose to the drain elbow. If using the barbs, install an automotive type clamp to secure the hose to the elbow. Place the other end of the hose at the drain point, and observe the following.

- **Fasten the hose in place** at the drain point. Pressurized water, exiting the hose during regenerations, could cause it to "whip".
- Provide an air-gap of at least 1-1/2" between the end of the hose and the floor drain cover. The air-gap prevents a possible back-siphon if sewer water should backup.
- For longer or raised drain hose runs, a 3/4" dia. hose (minimum) is recommended to reduce back-pressure. Back-pressure can restrict flow through the nozzle/venturi, affecting brine draw.
- If codes require a rigid drain pipe, purchase a *garden hose thread by compression* fitting, available from most hardware stores.

Figure 7

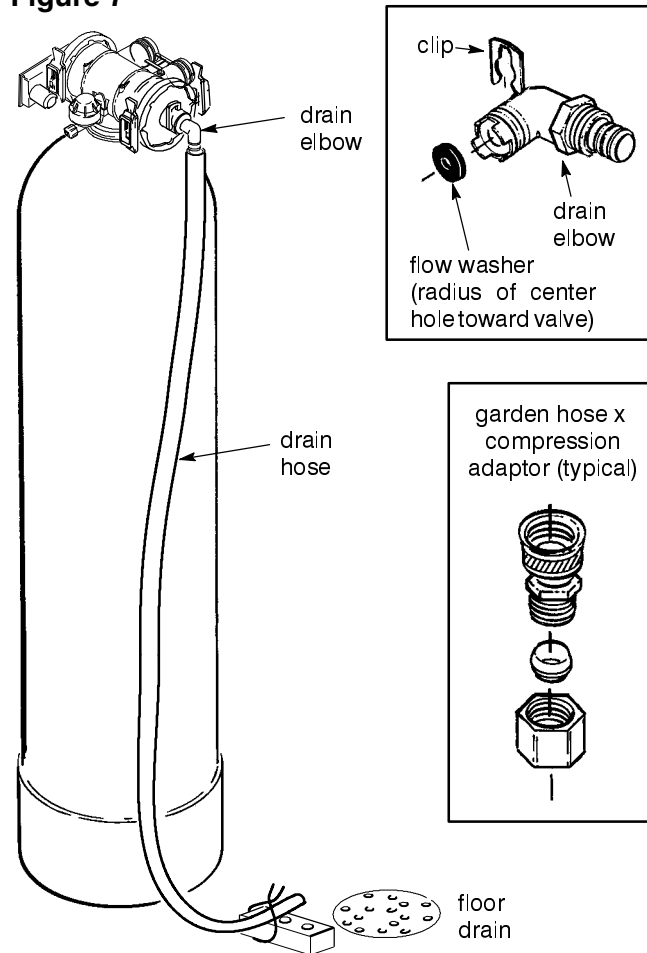

INSTALLATION STEPS

7. Pressure Testing: To prevent excessive air pressure in the resin tank and plumbing system, do the following steps in exact order.

- 1 Open two or more **soft** water faucets, both hot and cold.
- 2 Referring to Figure 8, place the bypass valve(s) in "service".
- 3 Slowly open the main water supply valve, pausing several times to allow the system to pressurize. When water from opened faucets runs smoothly, with no more air bubbles, close the faucets.
- 4 Check the installation for leaks. If any rework is needed, observe the cautions on page 9.

8. Fill the Brine Tank with Water and Salt: Using a pail or hose, add about 3 gallons of water into the brine tank. Add about 7 gallons into a 24" dia. tank.

Salt capacities are shown in the specifications. Fill the tank with **clean water softener salt**. Recommended nugget, pellet, solar, or button salts have less than 1% impurities. See page 23 for additional salt information.

9. Connect the controller cable(s) to the controller. Be sure the screws are tight. Note: The transformer must be unplugged before connecting or disconnecting controller cables. If not, it may result in damage to the controller circuits.

10. Connect the power cable to the two screw terminals on the transformer. Be sure the screws are tight. Plug the transformer into a grounded, 120V-60HZ outlet.

11. Program the controller to complete installation.

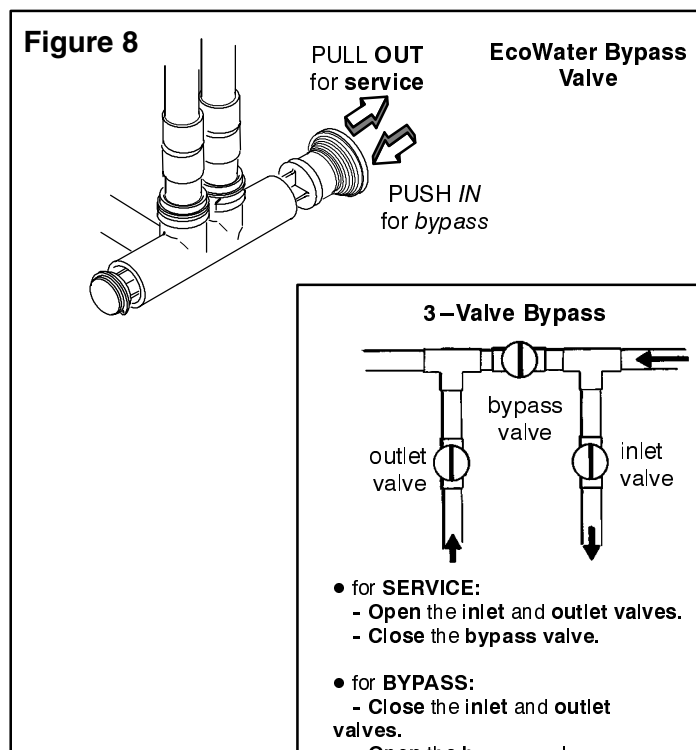

PROGRAMMING THE ELECTRONIC CONTROLLER AT STARTUP

(See page 15 to reset time and other settings, once programmed)

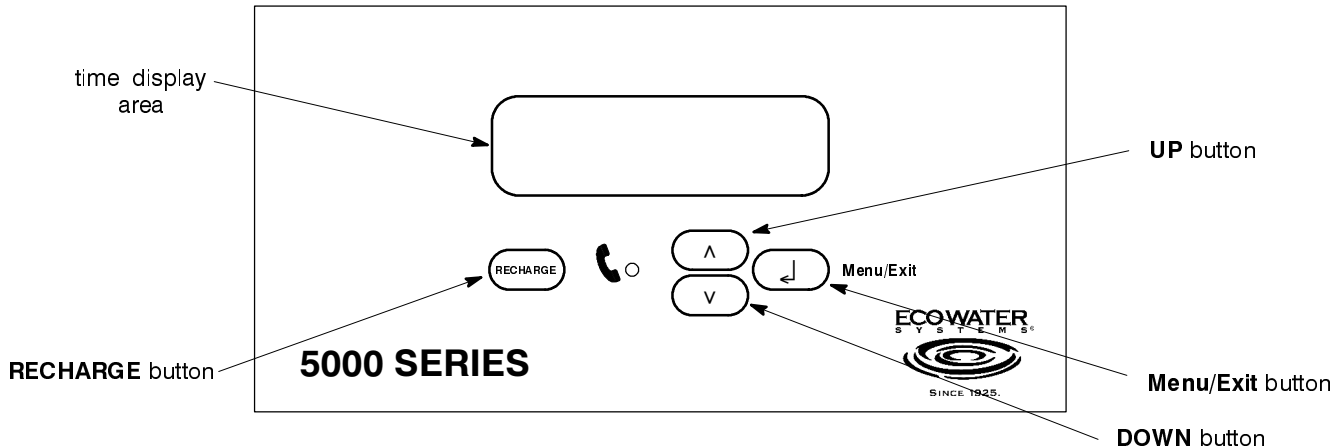

The electronic controller is a menu driven system with a dot matrix display. The Up (↑) and Down (↓) buttons move the cursor (>) up and down the menu choices. The Menu/Exit (↵) button enters the value selected and returns the display back a level. The controller will return to the normal operating screen after 4 minutes if left in a menu and no selection has been made.

● **SOUND “BEEPER”**- A “beeper” sounds while pressing buttons for controller setup. One beep signals a change in the faceplate display. Repeated beeps means the controller will not accept a change from the button you have pressed, telling you to use another button.

When the transformer is first plugged in, a screen is displayed for approximately 8 seconds showing the software version, then the following screens are displayed to program the controller.

1. SET LANGUAGE: Using the up (↑) or down (↓) buttons, move the cursor (>) next to the preferred language. Press the Menu/Exit (↵) button to select and advance to next setting.

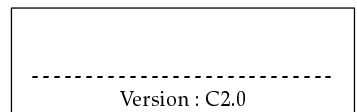

2. SET VALVE TYPE: Use the up (↑) or down (↓) buttons to display 1 inch dual disc valve. When the correct application is shown, press the Menu/Exit (↵) button to select and advance to next setting.

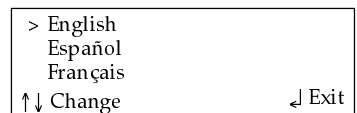

3. SET NUMBER OF VALVES: If one softener or filter is installed, set Simplex in the display using the up (↑) or down (↓) buttons, press the Menu/Exit (↵) button to select and advance to next setting. If multiple units are installed, set for Duplex, Triplex or Quadplex as applies for the installation.

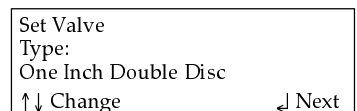

4. SET RECHARGE METHOD (for multiple tank applications only): There are two choices for recharge method. Parallel Immediate or Parallel Delayed. Parallel Immediate recharges each tank in sequence immediately as capacity is used. Parallel Delayed recharges each tank in sequence at the scheduled recharge time. Using the up (↑) or down (↓) button, select recharge method and press the Menu/Exit (↵) button to select and advance to next setting.

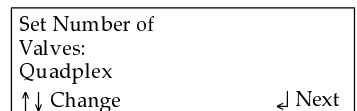

5. SET SYSTEM TYPE: Using the up (↑) or down (↓) button, select either softener or filter system type and press the Menu/Exit (↵) button to select and advance to next setting. If filter is selected, go to step 19 on page 14, for further settings.



6. SET RESIN QUANTITY: Using the up (↑) or down (↓) button, select amount of resin, in increments of .5 cubic feet (per tank), that will be used in the system. Press the Menu/Exit (↵) button to select and advance to next setting.



continued

PROGRAMMING THE ELECTRONIC CONTROLLER AT STARTUP

7. SET REFILL RATE: Using the up (↑) or down (↓) button, select refill rate to the suggested minutes from the table on page 24. Press the Menu/Exit (↵) button to select and advance to next setting.

Set Refill Rate: 2.0 GPM ↑↓ Change ↵ Next

8. SET EFFICIENCY MODE: Using the up (↑) or down (↓) button, select Salt Efficient, Boiler Option, Auto Adjusting or Actual Dose. Salt Efficient will obtain a salt efficiency of 4,000 grains or higher. Boiler Option will have 1 ppm soft water bleed or less. Auto Adjusting adjusts itself on 5 operating capacities, based on frequency of regenerations. Actual Dose allows user to set actual salt dose in lbs/cu. ft. If Actual Dose is selected, the controller will continue on to a Set Salt Dose screen. Press the Menu/Exit (↵) button to select and advance to next setting. Note: If Auto Adjusting is chosen, brine times will still need to be selected in step 10.

Set Efficiency Mode: Actual Dose ↑↓ Change ↵ Next

Set Salt Dose: 10 lb per ft3 ↑↓ Change ↵ Next

9. SET FIXED RESERVE: (Simplex or Parallel Delayed Systems only) If a minimum capacity must be available on any given day, use the up (↑) or down (↓) button to select the percentage of operating capacity required. See the chart on page 4 to determine actual capacity available. If Automatic is selected, the fixed reserve percentage varies, based on a weekly average of capacity used. Press the Menu/Exit (↵) button to select and advance to next setting.

Set Fixed Reserve: Automatic ↑↓ Change ↵ Next

10. SET BRINE TIME: Using the up (↑) or down (↓) button, select brine time to the suggested minutes from the table on page 24. Press the Menu/Exit (↵) button to select and advance to next setting.

Set Brine Time: 180 Minutes ↑↓ Change ↵ Next

11. SET BACKWASH TIME: Using the up (↑) or down (↓) button, select backwash time to the suggested minutes from the table on page 24. Press the Menu/Exit (↵) button to select and advance to next setting.

Set Backwash Time: 15 Minutes ↑↓ Change ↵ Next

12. SET FAST RINSE TIME: Using the up (↑) or down (↓) button, select fast rinse time to the suggested minutes from the table on page 24. Press the Menu/Exit (↵) button to select and advance to next setting.

Set Fast Rinse Time: 5 Minutes ↑↓ Change ↵ Next

13. SET SALT MONITOR FEATURE: Using the up (↑) or down (↓) button, display ON or OFF. If ON is selected, you must also enter the diameter of the brine tank. If this is a multiple valve application, and ON is selected, the number of Valves Per Brine Tank must be entered. Press the Menu/Exit (↵) button to select and advance to next setting.

Set Salt Monitor Feature: OFF ↑↓ Change ↵ Next

14. SET MINIMUM TANKS IN SERVICE (Triplex and Quadplex units only): Using the up (↑) or down (↓) button, display the minimum number of tanks that are needed to be in service at a time. Press the Menu/Exit (↵) button to select and advance to next setting.

Set Minimum Tanks In Service: 3 Tanks ↑↓ Change ↵ Next

15. After these initial settings are completed, the monitor will display a screen stating the controller is being reset. The monitor will then show a screen with the current settings before moving to the next screen and required setting.

Softener 1 Inch DD Quadplex ----- Version : C2.0

16. SET CLOCK: Using the up (↑) or down (↓) button, set the present time, being sure AM or PM shows, as applicable. By pressing and holding either the up (↑) or down (↓) button, the display will scroll at faster increments. Press the Menu/Exit (↵) button to select and advance to next setting. Note: Clock will need to be reset only if power was out longer than 72 hours.

Set Clock: 12: 00PM ↑↓ Change ↵ Exit

17. SET HARDNESS: Using the up (↑) or down (↓) button, set the water hardness level, from 1 to 160 grains or 10 to 2740 PPM (parts per million). By pressing and holding either the up (↑) or down (↓) button, the display will scroll at faster increments. Press the Menu/Exit (↵) button to select and advance to next setting.

Set Hardness: 25 Grains ↑↓ Change ↵ Exit

continued

18. SET RECHARGE TIME: This screen is active only if a single valve system or Parallel Delayed recharge setting. Using the up (↑) or down (↓) button, set the time when regenerations should start. Press the Menu/Exit (↵) button to select and advance to next setting.

Set Recharge Time: 2:00 AM ↑↓ Change	↵ Exit
-----------------------------------------------	--------

The monitor returns to the normal operating screen when programming has been completed.

Recharge Tonight At: 2:00 AM	12:03 PM
↵ Menu	

The installation, and programming steps are complete.

PROGRAMMING THE ELECTRONIC CONTROLLER AT STARTUP – FILTERS

19. SET FILTER CAPACITY: Using the up (↑) or down (↓) button, select OFF, or a pre chosen number of gallons, in 1000 gallon increments, at which you want the filter to backwash. If OFF is selected, the filter will not backwash automatically, and it must be initiated manually. Press the Menu/Exit (↵) button to select and advance to next setting.

Set Filter Capacity: 1000 ↑↓ Change	↵ Next
----------------------------------------------	--------

20. SET BACKWASH TIME: Using the up (↑) or down (↓) button, select backwash time from 1 minute minimum to 30 minutes maximum. The minimum time for filters is about 20 minutes. Increase the time as needed to thoroughly clean the filter bed. Press the Menu/Exit (↵) button to select and advance to next setting.

Set Backwash Time: 15 Minutes ↑↓ Change	↵ Next
--------------------------------------------------	--------

21. SET FAST RINSE TIME: Using the up (↑) or down (↓) button, select fast rinse time from 1 minute minimum to 30 minutes maximum. Press the Menu/Exit (↵) button to select and advance to next setting.

Set Fast Rinse Time: 5 Minutes ↑↓ Change	↵ Next
---------------------------------------------------	--------

22. SET MINIMUM TANKS IN SERVICE (Triplex and Quadplex units only): Using the up (↑) or down (↓) button, display the minimum number of tanks that are needed to be in service at a time. Press the Menu/Exit (↵) button to select and advance to next setting.

Set Minimum Tanks: In Service 3 Tanks ↑↓ Change	↵ Next
----------------------------------------------------------	--------

After these initial settings are completed, the monitor will display a screen stating the controller is being reset. The monitor will then show a screen with the current settings before moving to the next screen and required setting.

Filter 1 Inch DD Quadplex ----- Version : C2.0

23. SET CLOCK: Using the up (↑) or down (↓) button, set the present time, being sure AM or PM shows, as applicable. By pressing and holding either the up (↑) or down (↓) button, the display will scroll at faster increments. Press the Menu/Exit (↵) button to select and advance to next setting. Note: Clock will need to be reset only if power was out longer than 72 hours.

Set Clock: 12: 00PM ↑↓ Change	↵ Exit
-------------------------------------	--------

24. SET RECHARGE TIME: This screen is active only if a single valve system or Parallel Delayed recharge setting. Using the up (↑) or down (↓) button, set the time when regenerations should start. Press the Menu/Exit (↵) button to select and advance to next setting.

Set Recharge Time: 2:00 AM ↑↓ Change	↵ Exit
-----------------------------------------------	--------

The monitor returns to the normal operating screen when programming has been completed.

Water Flow Rate: 2.0 GPM	12:03 PM
↵ Menu	

The installation, and programming steps are complete.

ELECTRONIC CONTROLLER, RESETTING CONTROLLER, FEATURES AND OPTIONS

RESETTING TIME

To set the time if incorrect, or if the display is flashing after a power outage longer than 72 hours, reset as follows. When power is lost, all other settings are maintained by the computer and do not require setting (see Program Memory).

1. Press the Menu/Exit button (↵) to enter the Primary Menu. Using the up (↑) or down (↓) buttons, move the cursor (→) to Set Clock and press (↵) to enter this menu.

EXIT > Set Clock Set Hardness Set Recharge Time

2. Use the up (↑) and down (↓) buttons to set the correct time, being sure AM or PM shows, as applicable. Up (↑) advances the time; down (↓) moves the time backward.

Set Clock: 9:32PM ↑↓ Change ↵ Exit

3. When the correct time shows, press Menu/Exit (↵) to set the clock and return to the primary menu. Using the up (↑) or down (↓) buttons, move the cursor (→) to EXIT and press Menu/Exit button (↵) and return to the normal operating screen.

Water 9:32 PM Flow Rate: 2.0 GPM ↵ Menu

FEATURES AND OPTIONS

RECHARGE: By pressing this button, the controller enters into the recharge menu. The options are Online/Offline, Recharge Now or Recharge Tonight. Move the cursor (→) next to selection and press Menu/Exit (↵) button. Online/Offline allows a specific tank to be put online or taken offline. In the Recharge Now menu, you can select one or all tanks to start an immediate recharge. Move the cursor (→) next to the specific tank and press the Menu/Exit (↵) button. This will toggle between Service and Scheduled. In the Recharge Tonight menu, you can schedule a recharge or cancel a recharge tonight. Move the cursor (→) next to the specific tank and press the Menu/Exit (↵) button. This will toggle between Service or Tonight.

>EXIT Online/Offline Recharge Now Recharge Tonight

The following is a description of the features and options in the Primary Menu. To enter the Primary Menu, press the Menu/Exit (↵) button. Using the up (↑) or down (↓) button, move the cursor to the feature or option that you would like to change and press the Menu/Exit (↵) button to enter screen. To return to the normal operating screen, move the cursor (→) to EXIT and press Menu/Exit button (↵).

SET SALT LEVEL: This is activated if Salt Monitor feature is set to ON. Using the up (↑) or down (↓) button, set the salt level number from 0 to 10 or pressing the down (↓) button past 0 will toggle Salt Monitor to OFF. This number corresponds with the numbered decal on the brinewell that the salt level is closest to. Press the Menu/Exit (↵) button to set and return to the Primary menu. Note: This feature is not shown if System Type is set to Filter.

Set Salt Level: 8 ↑↓ Change ↵ Exit

SET CLOCK: Use the up (↑) and down (↓) buttons to set the correct time. If 12 hour clock is set, be sure AM or PM shows, as applies. Up (↑) advances the time; down (↓) moves the time backward. By pressing and holding either the up (↑) or down (↓) button, the display will scroll at faster increments. Press the Menu/Exit (↵) button to set and return to the Primary menu.

Set Clock: 9:32PM ↑↓ Change ↵ Exit

SET HARDNESS: (Softeners only) Using the up (↑) or down (↓) button, set the water hardness level, from 1 to 160 grains, or 10 to 2740 PPM (parts per million). By pressing and holding either the up (↑) or down (↓) button, the display will scroll at faster increments. Move the cursor (→) to EXIT and press Menu/Exit button (↵) and return to the normal operating screen.

Set Hardness: 25 Grains ↑↓ Change ↵ Exit

SET RECHARGE TIME: Using the up (↑) or down (↓) button, set the time when regenerations should start. Press the Menu/Exit (↵) button to set and return to the Primary menu. Move the cursor (→) to EXIT and press Menu/Exit button (↵) and return to the normal operating screen. Note: This feature is available only on parallel delayed systems and not available if System Type is set to Filter.

Set Recharge Time: 2:00 AM ↑↓ Change ↵ Exit

continued

FEATURES AND OPTIONS

FLOW RATE: This screen is for viewing the flow rate, in GPM or LPM, through each individual tank, depending on the configuration (simplex, duplex, etc.). Press the Menu/Exit (↵) button to return to the Primary menu. Move the cursor (→) to EXIT and press Menu/Exit button (↵) and return to the normal operating screen.

T1: 2.5 GPM	
T2: 3.1 GPM	
T3: 1.6 GPM	
T4: 2.8 GPM	↵ Exit

WATER USED TODAY: This screen displays the number of gallons or liters that have been used in each individual tank per 24 hour time period, depending on the configuration (simplex, duplex, etc.). Press the Menu/Exit (↵) button to return to the Primary menu. Move the cursor (→) to EXIT and press Menu/Exit button (↵) and return to the normal operating screen.

T1: 5 Gallons	
T2: 8 Gallons	
T3: 4 Gallons	
T4: 6 Gallons	

AVERAGE DAILY WATER USE: This screen displays the *average* number of gallons or liters that have been used in a 24 hour time period. Press the Menu/Exit (↵) button to return to the Primary menu. Move the cursor (→) to EXIT and press Menu/Exit button (↵) and return to the normal operating screen.

System Average Daily Water Use: 300 Gallons	↵ Exit
------------------------------------------------	--------

CAPACITY REMAINING: This screen displays the percent capacity remaining in each individual tank, depending on the configuration (simplex, duplex, etc.). Press the Menu/Exit (↵) button to return to the Primary menu. Move the cursor (→) to EXIT and press Menu/Exit button (↵) and return to the normal operating screen. Note: Not available for filters that have Filter Gallons set to OFF (step 19). Screen will show "Filtering Water".

Capacity Remaining %: T1: 25% T3: 48% T2: 33% T4: 37%	↵ Exit
-------------------------------------------------------------------	--------

Filtering Water	12:22PM
	↵ Exit

SET 12/24 HOUR CLOCK: Using the up (↑) or down (↓) button, set the time to either a 12 or 24 hour clock. Press the Menu/Exit (↵) button to set and return to the Primary menu. Move the cursor (→) to EXIT and press Menu/Exit button (↵) and return to the normal operating screen.

Set 12/24 Hour Clock: 12 Hour ↑↓ Change	↵ Exit
-----------------------------------------------	--------

SET ENGLISH/METRIC: Using the up (↑) or down (↓) button, set the controller to measure in English or Metric units. Press the Menu/Exit (↵) button to set and return to the Primary menu. Move the cursor (→) to EXIT and press Menu/Exit button (↵) and return to the normal operating screen.

Set English/Metric English ↑↓ Change	↵ Exit
--------------------------------------------	--------

SET ROLLING SCREEN: Using the up (↑) or down (↓) button, set this ON or OFF. If set to ON, the normal operating screen will scroll from Soft Water Available, which shows the capacity remaining in each tank, to Water Flow Rate and Salt Level is Low (if applicable). If there is a recharge scheduled, Recharge Tonight will also be displayed. Press the Menu/Exit (↵) button to set and return to the Primary menu. Move the cursor (→) to EXIT and press Menu/Exit button (↵) and return to the normal operating screen.

Set Rolling Display Screens OFF ↑↓ Change	↵ Exit
-------------------------------------------------	--------

REMOTE STATUS: This is a new optional feature for use. A remote monitor can be conveniently placed for viewing your conditioners status. This screen will show if the remote monitor setting has been turned on, and the status of the system (OK, low salt, check system). Press the Menu/Exit (↵) button to set and return to the Primary menu. Move the cursor (→) to EXIT and press Menu/Exit button (↵) and return to the normal operating screen.

Remote: Installed Status: System OK	↵ Exit
----------------------------------------	--------

SEND SERVICE MESSAGE: This option may or may not be available. Press the Menu/Exit (↵) button and the controller automatically starts sending the service message in a series of beeps to be transmitted by phone. The display shows the how much of the message has been sent and a progress bar. To cancel the transmission press the Menu/Exit (↵) button. When message has been sent, the controller returns to the normal operating screen. Contact your installer for more information on service messages.

Sending Message 56% ■■■■■□□□□□	↵ Exit
------------------------------------------	--------

continued

FEATURES AND OPTIONS

ADVANCED SERVICE: By entering these menus, a warning screen will first be displayed. Only technicians or knowledgeable users should access these menus.

WARNING: Changes could affect unit performance.
 ↑ Continue ↓ Cancel

The following is a description of the features and options in the Advanced/Service Menu. To enter the Advanced/Service Menu, press the Menu/Exit (↵) button. Using the up (↑) or down (↓) button, move the cursor to Advance/Service and press the Menu/Exit (↵) button. The warning screen will show, press the up (↑) button to continue. To return to the Primary Menu, move the cursor (>) to EXIT and press Menu/Exit button (↵).

SET LANGUAGE: Using the up (↑) or down (↓) buttons, move the cursor (>) next to the preferred language. Press the Menu/Exit (↵) button to select and return to the Advance/Service Menu screen.

> English
 Español
 Français
 ↑↓ Change ↓ Exit

DIAGNOSTICS: This screen is for viewing only and will show any error codes plus information on each individual tank, depending on the configuration (simplex, duplex, etc.). Move the cursor (>) next to the specific tank and press the Menu/Exit (↵) button. Press the Recharge button and the valve will step through each cycle of the valve. Use the up (↑) or down (↓) buttons to view all lines of the screen. Press Menu/Exit button (↵) to return to the diagnostics screen.

>EXIT
 Tank 1: Online
 Tank 2: Online
 Tank 3: Online

12:04:48PM Error0 ↑
 Pos: SERVICE 0:00
 Req Pos: SERVICE
 Motor: ON Sw:OPEN ↓

TEST REMOTE: At set up, the unit will send a signal to the remote every 3 seconds to allow for correct positioning of remote monitor. Press Menu/Exit (↵) to exit. Press the Menu/Exit (↵) button to return to the Advance/Service Menu screen. Note: This feature is not available if the optional remote is not installed in the controller.

Test Remote:
 Sending Message
 ↓ Exit

During normal operation, the green LED will flash at intervals of 5 seconds. If the unit requires salt, the amber LED will flash, and if the unit needs to be checked the red LED will flash.

The controller on the unit will send a signal to the remote monitor every minute. The remote monitor will listen for a signal every 10 minutes. Any changes in softener status could possibly take up to 10 minutes before the remote registers the change. If the unit stops sending a signal, the remote will keep trying to listen for the signal. If after 10 minutes with no signal received, the remote will try 1 minute later and 2 minutes later to find the signal, gradually increasing the time between, but will keep trying to listen for the signal for up to 2 days. After 20 minutes with no signal received, the remote monitor will turn off the LED's to conserve battery life, but will still be active. After 2 days with no signal received, the remote monitor will shut down until the reset button is pushed (on back of remote).

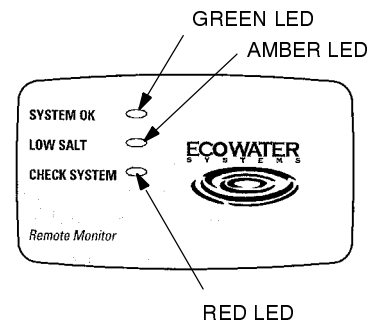

The remote uses 3 “AAA” batteries, which are included. To check batteries, press reset button on back of remote monitor. If batteries are good, the LED's on the remote should scroll green, amber, red. If LED's do not light, batteries need to be changed.

If there is another unit within range of the remote, it may cause a conflict with the channel that the remote monitor is receiving. If the remote monitor displays the wrong message (example: low salt when salt is above warning level) this is an indication that the remote monitor is receiving a different signal. Follow the steps below to change the remote channel.

NOTE: This device complies with Part 15 of the FCC Rules. Operation is subject to the following two conditions: (1) this device may not cause harmful interference, and (2) this device must accept any interference received, including interference that may cause undesired operation. Changes or modifications not expressly approved by the party responsible for compliance could void the user's authority to operate the equipment.

SET REMOTE CHANNEL: Press (↑) or (↓) to select a new channel from 1 to 16. Press the Menu/Exit (↵) button to select, and press reset button on back of remote monitor. Note: This feature is not available if a remote is not installed.

Set Remote
 Channel:
 13
 ↑↓ Change ↓ Exit

continued

FEATURES AND OPTIONS

SET LOW SALT ALERT: Press (↑) or (↓) to change Alert Level from 0 to 4. This number corresponds with the numbers on the brinewell. When the salt level falls below this level the controller will signal that salt needs to be added to the brine tank. Press the Menu/Exit (↵) button to select and return to the Advanced/Service menu. Note: Not available for if System Type (step 5) is set to Filter.

Set Low Salt Alert Level: 2 ↑↓ Change	↵ Exit
------------------------------------------------	--------

SET MAX DAYS/RECHARGE: Press (↑) or (↓) to change Max Days Between Recharges. If Automatic is selected, the algorithm will determine when to recharge. If 1 to 15 is selected, the unit will never go past the number of days set for a recharge, but could recharge before. Press the Menu/Exit (↵) button to select and return to the Advanced/Service menu.

Set Max Days Between Recharges: Automatic ↑↓ Change	↵ Exit
--------------------------------------------------------------	--------

SET 97% FEATURE: Press (↑) or (↓) to set either OFF or On. If ON is selected, the unit will automatically recharge when 97% capacity has been used, at any time of the day. Press the Menu/Exit (↵) button to select and return to the Advanced/Service menu. Note: This feature is available for single tank or Parallel Delayed configurations only.

Set 97% Recharge Feature: OFF ↑↓ Change	↵ Exit
--------------------------------------------------	--------

SET CHLORINE/BYPASS: This feature is for European units. Press (↑) or (↓) to set on Bypass, Chlorine-Half Wave or Chlorine-Full Wave. Press the Menu/Exit (↵) button to select and return to the Advanced/Service menu.

Set Chlorine/ Bypass Bypass ↑↓ Change	↵ Exit
---------------------------------------------	--------

VALVE CONFIGURATION: This option allows you to reprogram the controller. After all valve configuration selections have been made, all other settings (clock, water hardness, etc.) will need to be reset. Note: The controller will also reset all counts back to zero (number of recharges, etc.), except for the number of days in service.

Set Valve Type: Two Inch Upflow ↑↓ Change	↵ Next
----------------------------------------------------	--------

OPERATION

CONTROLLER AND WATER METER

The controller is actually a small computer. As it receives pulses from the water meter it converts them to gallons of water passing through the unit. It multiplies this water usage information times the water hardness (preprogrammed into timer) to continually calculate the conditioned water capacity required. The computer adjusts daily to water using habits, seeking to supply conditioned water for the longest time, using the least (and most efficient) amount of salt and water to regenerate.

When the computer determines more capacity is needed, at the next regeneration starting time (2:00 a.m., or as otherwise preset), it will schedule a regeneration. RECHARGE TONIGHT shows in the display to inform of the coming regeneration.

The water meter is located in the 1" valve outlet. It consists of a turbine, turbine mounting assembly, and a sensor housing pickup (Figure 9). The turbine and sensor pickup are oriented in-line, centered in the water stream. Water flow turns the turbine, which houses two small magnets. As the turbine spins, the magnets cause the sensor pickup to switch back and forth. This switching sends an electrical pulse through the sensor leads, to the circuit board computer. The computer counts the pulses and converts them to gallons. The sensor is in a sealed chamber to keep out dirt, moisture and corrosion.

Figure 9

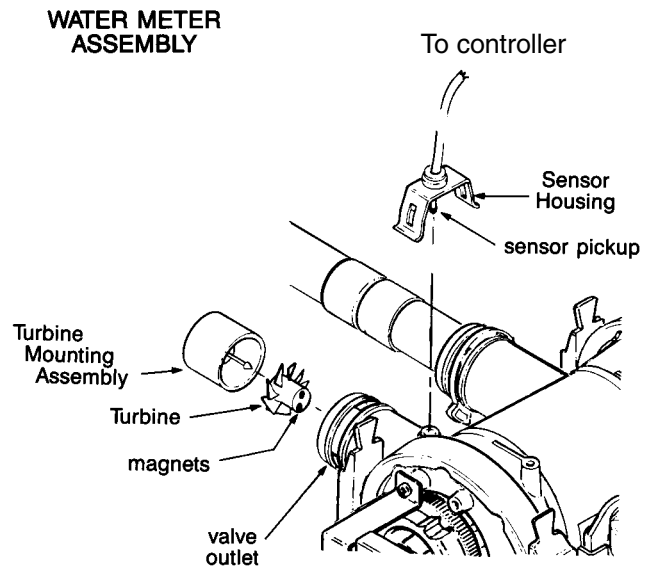

OPERATION – WATER FLOW THROUGH THE SYSTEM

The system is filled with a man-made resin material called the resin bed. Resin looks somewhat like coarse sand, but the resin beads are round and smooth. This resin has the ability to remove hardness minerals from water by ion-exchange. The resin bed is supported by a layer of one or more grades of quartz gravel that fills the bottom dome of the tank, and covers the bottom distributor.

SERVICE (FIG. 10): Hard water enters the system, passes through the valve, and flows down into the resin tank and resin bed. As it passes through the bed, hardness minerals are extracted from the water and held by the resin beads. Conditioned water exits the resin tank through the bottom distributor, flows up the internal standpipe, into the valve, then out to faucets or other usage.

In time, the resin beads hold all of the hardness minerals they can, and cleaning with a salt solution (brine) is needed. Regeneration and recharge are words used to describe this cleaning.

OPERATION – WATER FLOW THROUGH THE SYSTEM

SERVICE
Figure 10

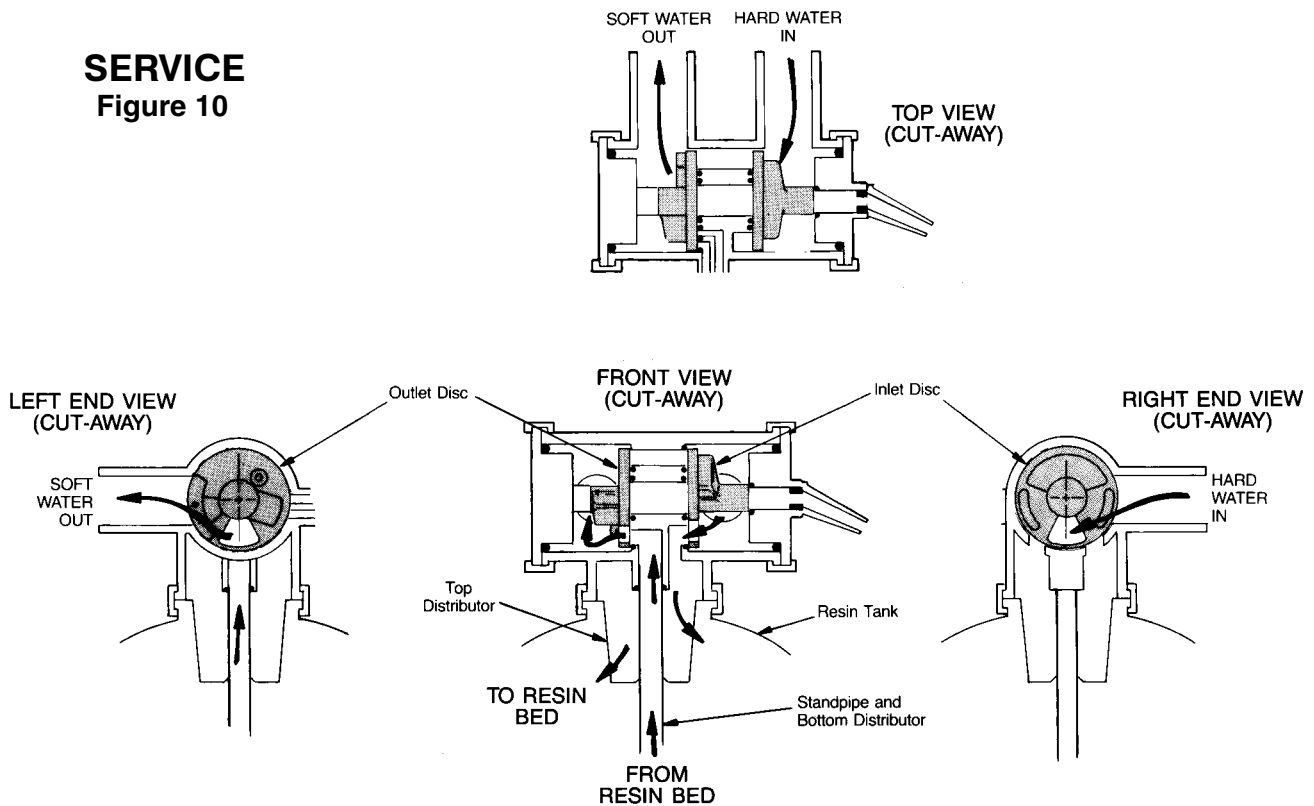

REGENERATION, or RECHARGE: The programmed faceplate timer starts regenerations at 2:00 AM, or other preset time. Regeneration consists of 5 steps, or cycles. These are **fill**, **brining**, **brine rinse**, **backwash** and **fast rinse**.

FILL (FIG.11): Salt dissolved in water is called brine. Brine is the cleaning agent to remove hardness minerals from the resin bed. To make brine, water is needed in the brine tank salt storage area. A controlled water flow to the brine tank occurs during **fill**. The 1" valve repositions slightly (motor energized). A passage opens allowing conditioned water to flow through the nozzle/venturi, to the brine valve, and into the brine tank.

Fill cycle length is regulated automatically by the controller.

BRINING/BRINE RINSE (FIG. 12): The timer energizes the valve motor to move the valve into brining. A port opens to route water to the nozzle. Flow through the nozzle and venturi creates a suction on the brine tubing and brine valve, drawing brine from the salt storage area. Brine mixes with water at the nozzle/venturi, and travels back to the valve. Flow continues down the internal standpipe and into the resin bed. As brine passes through the resin bed, hardness minerals are released from the resin and carried with the flow of water, to the drain.

After all brine is drawn from the brine tank, the brine valve float seats to prevent air induction. Water flow continues in the same direction to slowly rinse brine and hardness minerals to the drain. Brining/brine rinse times are shown in the tables on page 24.

BYPASS HARD WATER: During the brining, brine rinse, backwash and fast rinse cycles of regeneration, *hard* water is bypassed through the valve and is available if needed. You should **avoid using hot water**, if possible, because the water heater will refill with hard water.

continued, page 22

OPERATION – WATER FLOW THROUGH THE SYSTEM

FILL
Figure 11

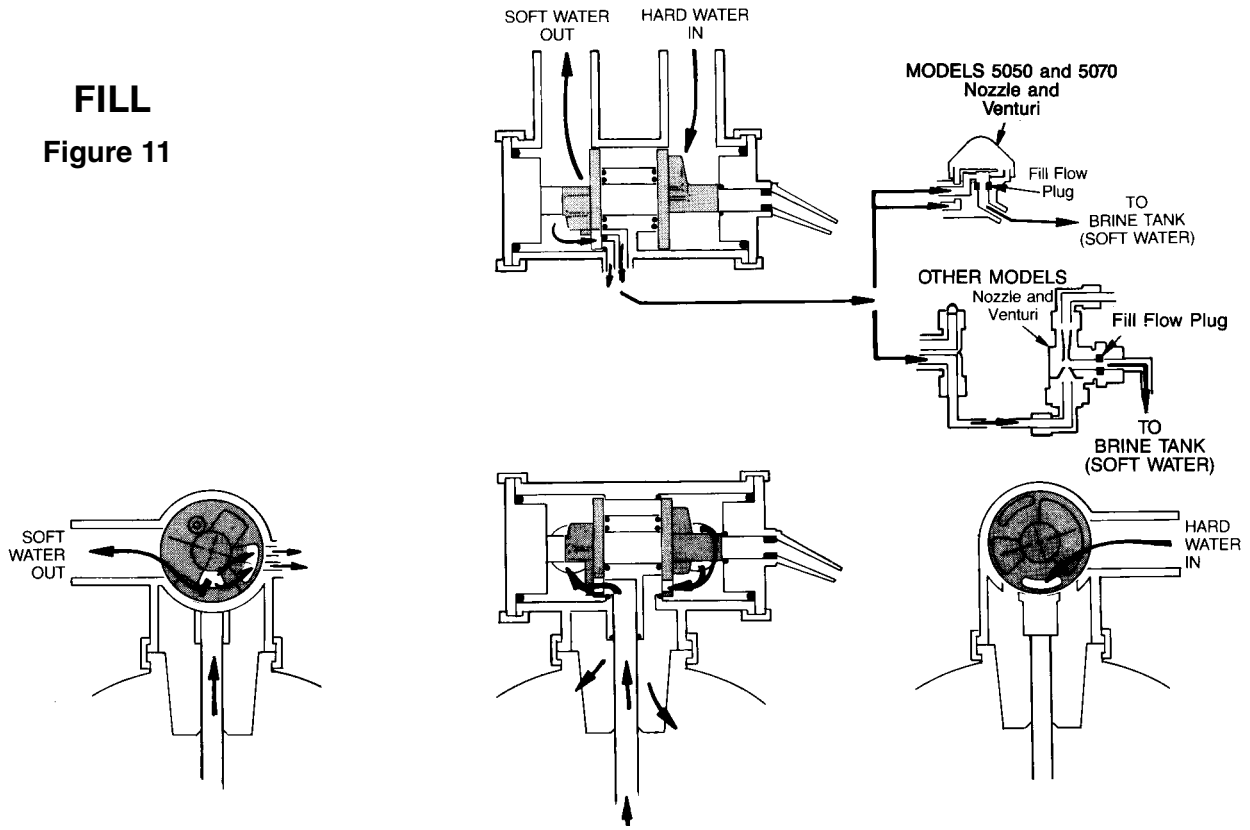

BRINING and BRINE RINSE
Figure 12

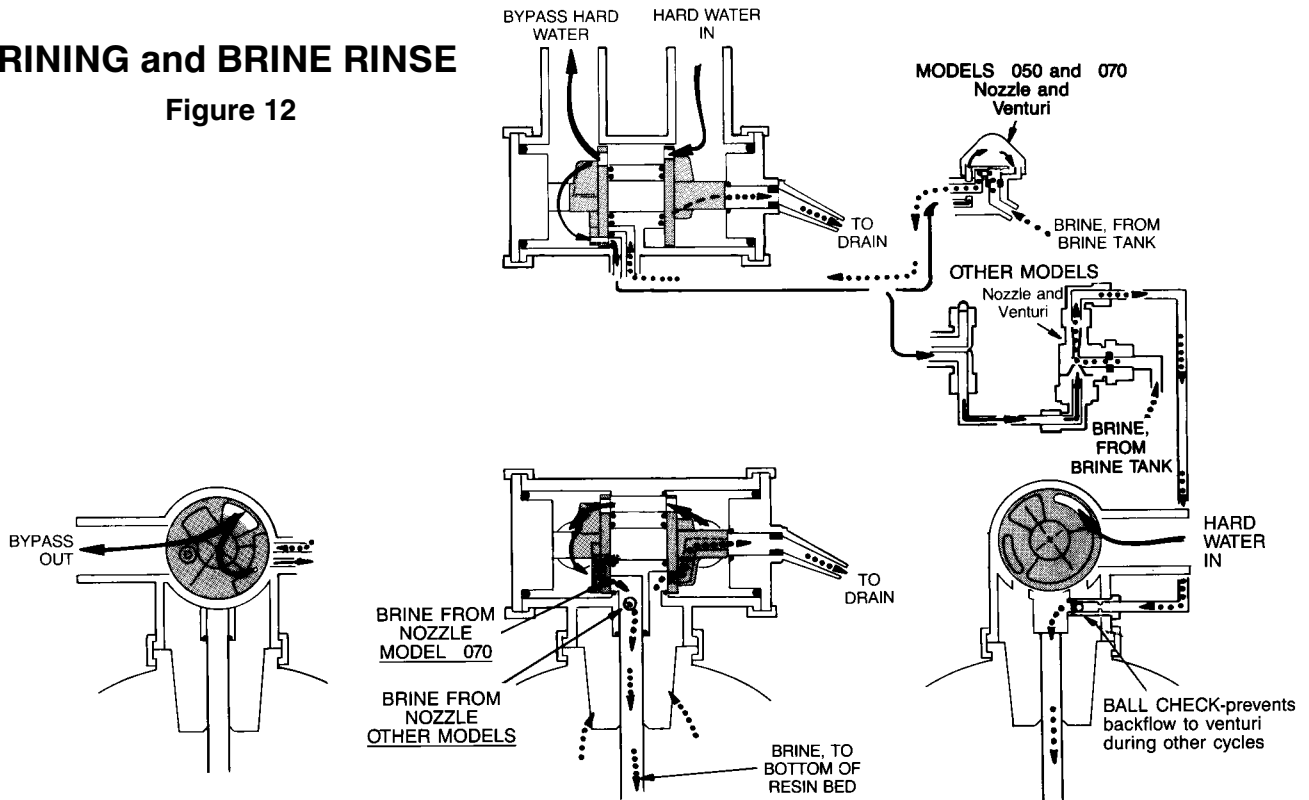

OPERATION – WATER FLOW THROUGH THE SYSTEM

BACKWASH

Figure 13

The motor drives the valve to end brine rinse and reposition in backwash. In backwash, a fast upward flow of water through the resin bed flushes remaining hardness minerals, brine, dirt, sediments, iron deposits, etc., from the bed and to the drain. The fast flow lifts and expands the resin bed for maximum cleaning.

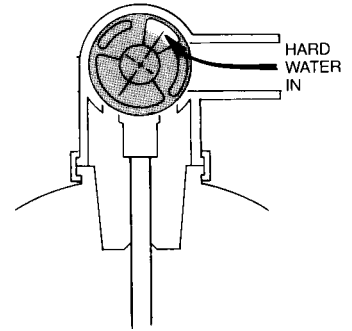
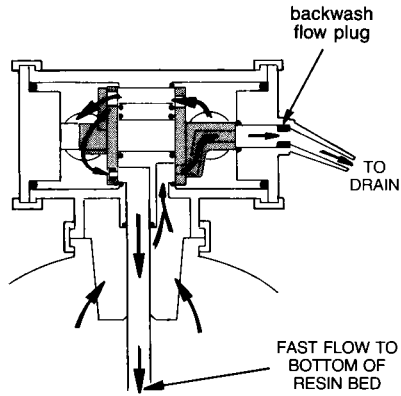
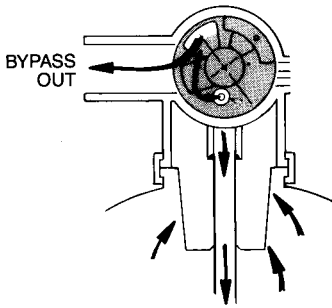
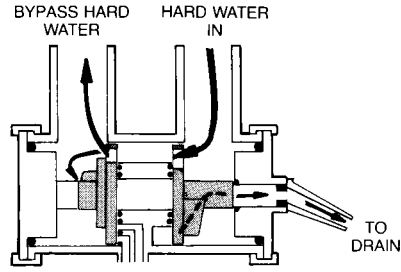

FAST RINSE

Figure 14

After backwash, valve rotation places the unit in fast rinse. A continued fast flow of water reverses direction, flowing down through the bed. Any hardness minerals, brine, etc., remaining at the bottom of the bed are flushed up the standpipe, and to the drain. The fast flow packs the resin bed in preparation for service.

The valve motor is energized a final time to drive the valve to service position.

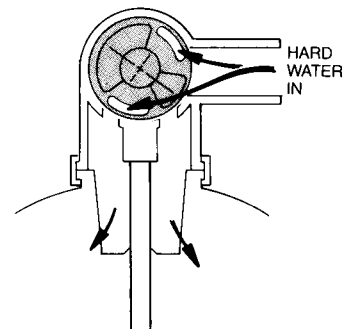
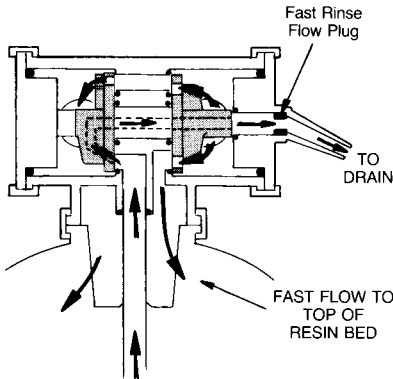
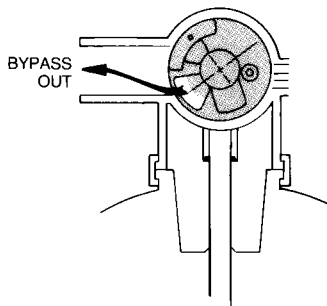
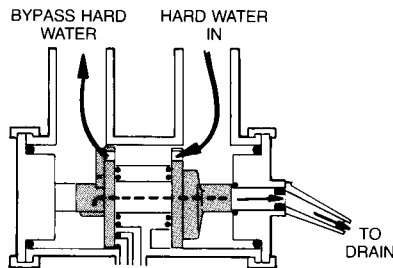

SERVICE INFORMATION

REFILLING WITH SALT

Remove the brine tank cover and check the salt storage level frequently. Always refill if less than 1/2 full. **BE SURE THE BRINE-WELL COVER IS ON.**

NOTE: In humid areas, it is best to keep the salt storage level lower, and to refill more often.

RECOMMENDED SALT: Nugget, pellet, solar, button, etc. water conditioner salt is recommended. This type of salt is formed, or compressed into briquets, from high purity evaporated crystals. It has less than 1% insoluble (will not dissolve in water) impurities. Clean, high grade rock salts are acceptable, but may require frequent brine tank cleaning to remove the "sludge" residue (insolubles).

SALT NOT RECOMMENDED: Rock salt, high in impurities, block, granulated, table, ice melting, ice cream making salts, etc. are not recommended.

SALT WITH IRON REMOVAL ADDITIVES: Some salts have an additive to help the unit handle iron in the water supply. Although this additive may help keep the resin clean, it may also release corrosive fumes that will weaken and shorten the life of some parts.

BREAKING A SALT BRIDGE

Sometimes, a hard crust or salt bridge forms in the brine tank. It is usually caused by high humidity or the wrong kind of salt. When the salt bridges, an empty space forms between the water and salt. Then salt will not dissolve in the water to make brine. Without brine, the resin bed does not regenerate and you will have hard water.

If the storage tank is full of salt, it is hard to tell if you have a salt bridge. Salt is loose on top, but the bridge is under it. Take a broom handle, or like tool, and push it straight down into the salt. If a hard object is felt, it's most likely a salt bridge. Carefully push into the bridge in several places to break it.

CLEANING THE NOZZLE & VENTURI

A clean nozzle and venturi is a must for the softener to work right. This small unit moves brine from the brine tank to the resin tank during regeneration. If it becomes plugged with sand, silt, dirt, etc. the softener will not work and you will get hard water.

These models use two different nozzle assembly designs. Figure 15 shows the assembly used on EWS 050 and EWS 070 models. All other models use the nozzle assembly in Figure 16, on page 24.

Figure 15

Be sure the unit is in service cycle (no water pressure at nozzle and venturi), then turn off the cap from the nozzle and venturi housing. **DO NOT LOOSE THE LARGE O-RING SEAL.** Lift out the screen support and screen, then the nozzle and venturi. Wash and rinse the parts in warm water until clean. If needed, use a small brush to remove iron or dirt. Also, check and clean the gasket and flow plug if dirty.

Carefully replace all parts in the correct order. Lubricate the o-ring seal with silicone grease or Vaseline and place in position. Install and tighten the cap, **BY HAND ONLY. DO NOT OVERTIGHTEN AND BREAK THE CAP OR HOUSING.**

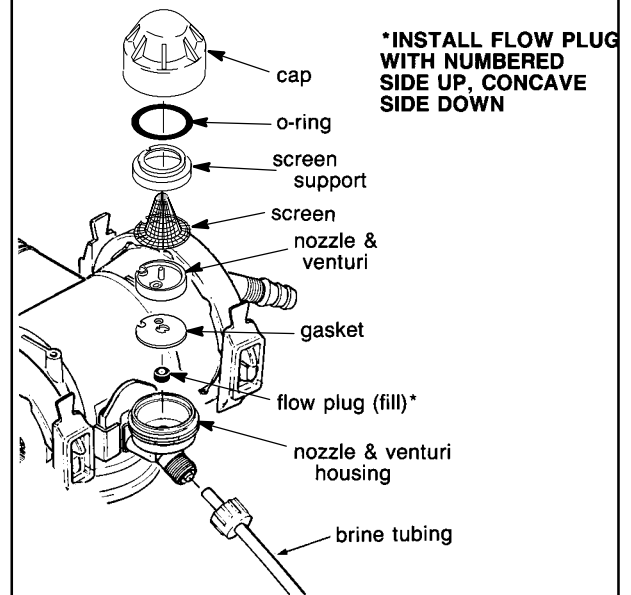

SERVICE INFORMATION

	MODEL						
	EWS050	EWS070	EWS100	EWS130	EWS190	EWS250	EWS320
FILL CYCLE FLOW RATE (GPM)	.3	.3	.3	.3	.5	.5	.5
FILL FLOW PLUG LOCATION	See Key No. 29, page 32		See Key No. 18, page 36				
BRINE CYCLE FLOW RATE (GPM)	.27	.27	.58	.57	1.1	1.1	1.1
BR. RINSE CYCLE FLOW RATE (GPM)	.19	.19	.48	.47	.89	.89	.89
BKW. CYCLE, & FAST RNS. CYCLE FLOW RATE (GPM)	3	3	7	7	10	10	10
BKW. FAST RNS. FLOW PLUG IDENTIFICATION & LOCATION	.18 (3)		.25 (3D)		.28 (10B)		
	Behind Drain Elbow of 1" Valve (see page 10)						
AMOUNT OF RESIN (CU. FT.)	1.5	2	3	4	6	8	10
AMOUNT OF GRAVEL (LBS.)							
FINE	17	17	34	34	50	50	50
MEDIUM	-	-	-	-	50	50	50
COARSE	-	-	-	-	50	50	50
*FREEBOARD (INCHES)	27	19	30	22	36	27	18

*Nominal distance from top of resin bed, to top of the tank. This dimension can vary several inches, depending on resin moisture content, degree of bed expansion or packing, resin tank diameter tolerances, etc.

		MODEL						
		EWS050	EWS070	EWS100	EWS130	EWS190	EWS250	EWS320
FILL CYCLE TIME (MIN.)	LOW	6.7	8.9	13.4	17.9	16.1	21.4	26.8
	HIGH	25.1	33.5	50.2	67.0	60.5	80.4	100.45
BRINING/ BR. RNS. CYCLE TIME (MIN.)	LOW SALT	108	144	115	160	150	160	180
	HIGH SALT	63	84	95	130	125	130	150
BACKWASH CYCLE TIME (MIN.) *		15	15	15	15	15	15	15
FAST RINSE CYCLE TIME (MIN.) *		5	5	5	5	5	5	5

*Factory default setting...see page 13.

Figure 16

NOZZLE ASSEMBLY
ALL MODELS
EXCEPT EWS050 & EWS070

NOTE: SMALL HOLE THROUGH REDUCER BUSHING MAY REQUIRE FREQUENT CLEANING.

Labels in diagram: NOZZLE & VENTURI HOUSING, VENTURI, NOZZLE, O-RING, NOZZLE HOUSING, brine valve assembly.

BE SURE UNIT IS IN SERVICE POSITION (NO WATER PRESSURE AT NOZZLE ASSEMBLY).

1. Disconnect bottom tubing at the nozzle assembly and turn nozzle housing out of nozzle and venturi housing.
2. Turn nozzle out of nozzle housing. Remove venturi with a long, needle-nose pliers, if needed (can clean center hole of venturi without removing).
3. Clean parts in hot soapy water. Use a small wire to clean holes in the nozzle and venturi. USE EXTREME CARE NOT TO SCRATCH, ENLARGE OR MISSHAPE THE HOLES, OR SURFACES AROUND THEM. Flush parts in fresh, clean water.
4. Reassemble all parts, being sure to seat the nozzle and venturi in their respective locations. DO NOT OMIT THE O-RING SEAL ON THE NOZZLE.
5. Replace the nozzle housing and reconnect the tubing.

SERVICE INFORMATION, ELECTRONIC DEMAND TIMER MODELS

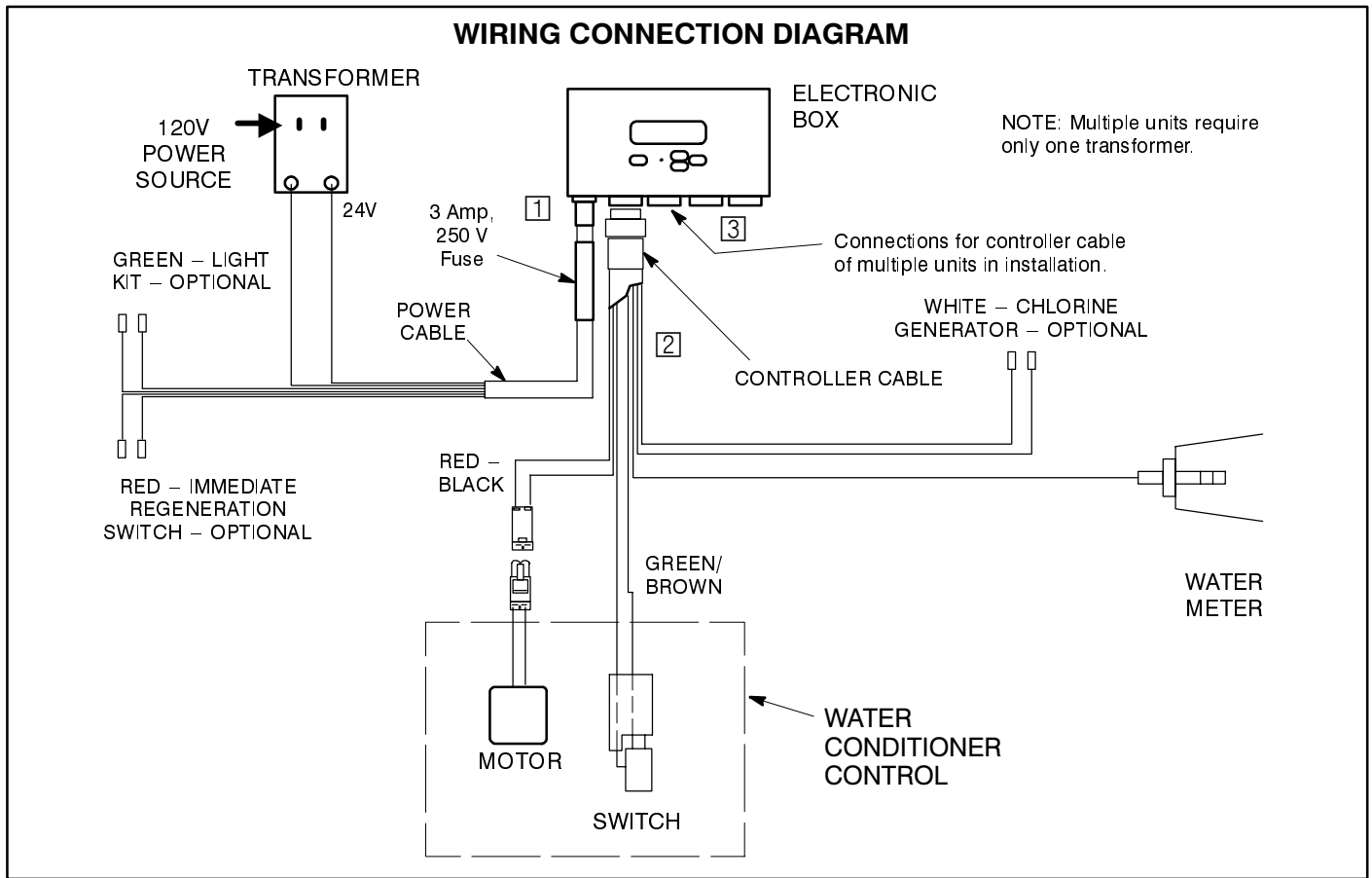

E.A.S.E.: EcoWater controllers have the latest diagnostic technology. With E.A.S.E., or Electronic Automated Service Evaluation, a service person, or the commercial systems operator, can transmit operational data through the telephone, to a personal computer (PC). The PC processes the data to determine if all electrical functions are working normally, or helps to identify a problem should one occur. Ask your participating dealer for more information on this feature.

SERVICE INFORMATION, ELECTRONIC CONTROLLER

TROUBLESHOOTING

ALWAYS MAKE THE **INITIAL CHECKS** FIRST:

1. Does the time display show the correct time of day?
...If display is blank, check power source to the conditioner.
...If display is blank, check the fuse on the power cord.
...If time is flashing, power was off for longer than the built-in program memory. The conditioner resumes normal operation, when power returns, but regenerations occur at the wrong time.
...If an error code shows in the display (example: Error3), go to AUTOMATIC ELECTRONIC DIAGNOSTICS, page 27.
2. Plumbing bypass valve(s) must be in service position (all the way open or closed, as applies. . . see page 11).
3. Inlet outlet and drain pipes must connect to the conditioner as typically shown on page 8.
4. Is the transformer plugged into a “live”, grounded wall outlet, and the power cable fastened securely?
5. Is there salt in the brine tank? Check to be sure it is not bridged or caked (see page 23).
6. Is the brine tubing connected? See step 3, page 9.
7. Double check the Hardness setting. Press the Menu/Exit (↵) button, move the cursor (>) to Set Hardness and press the Menu/Exit (↵) button. Be sure it is the correct setting for the water supply. Make a hardness test of the raw water and compare with the hardness setting. If the water contains iron, be sure to add 5 to the hardness number for each 1 ppm. Also test a conditioned water sample to verify if a problem exists. Press the Menu/Exit (↵) button to return to Primary menu, move cursor to EXIT and return to normal operating screen.

If you do not find a problem after making the initial checks, do MANUAL ELECTRONIC DIAGNOSTICS, and the MANUAL ADVANCE REGENERATION CHECK, page 28.

AUTOMATIC ELECTRONIC DIAGNOSTICS

The timer computer has a self-diagnostic function for the electrical system (except input power and water meter). The computer monitors electronic components and circuits for correct operation. If a malfunction occurs, an error code appears in the timer display area of the electronic box.

Error # 3
 Tank #1
 Recharge to Retry
↵ Menu

The chart below shows the error codes that could appear, and the possible defects for each code.

While an error code appears in the display, the tank is taken offline and either the Recharge button or Menu/Exit (↵) can be used. Menu/Exit (↵) remains operational so the service person can make the Manual Electronic Diagnostics to further isolate the defect, and check the water meter.

If Recharge is pressed, the display will show the diagnostics screen and cycle the valve through all positions to try to correct the error itself. After it is done retrying, the display reverts back to the run screen (either showing error code again or normal run screens).

If the controller successfully fixes the problem in the diagnostics display, the unit automatically is placed back online by the software. There would be no need to go into the online/offline screen to put the unit back online.

PROBLEM	POSSIBLE DEFECT	POSSIBLE SOLUTION
No display.	No power to outlet.	Check the outlet by plugging in another appliance.
	Fuse blown.	Check fuse in power cable. REPLACE WITH SAME TYPE AND VALUE: AGC 3A 250V.
	Internal transformer fuse blown.	Plug the transformer into an outlet and measure output voltage with a multimeter. Should be between 24 and 30 volts AC.
Fuse keeps blowing.	Wiring harness shorted or not connected properly.	Check connections at controller box and valve. Connect all other wires before plugging transformer into outlet.
Error code 1, 3 or 4.	Wiring harness not connected or not connected properly.	Check connections at controller box and valve. Check for corrosion at connection points.
	Incorrect position switch connections.	Check valve switch connections.
	Incorrect valve type selected on new install or upgrade to system.	Check proper valve configuration is selected controller box.
	Valve motor running slow, or not at all.	Initiate a recharge and step valve through all positions. Check motor for consistent movement. If slow, check motor and valve seals.
Error code 6	Optional immediate regeneration switch is stuck in the on position.	Check red wires from power cable for possible shorts, check immediate regeneration switch.

Procedure for removing error code from faceplate: Press the RECHARGE button, or: **1.** Unplug transformer---- **2.** Correct defect---- **3.** Plug in transformer---- **4.** Wait for 6 minutes. The error code will return if the defect was not corrected.

MANUAL ELECTRONIC DIAGNOSTICS

1. Do the preceding (page 26) INITIAL CHECKS first.
2. Enter the diagnostics screen on the controller (page 27) and using the down (↓) button, view the turbine information.

Pos: SERVICE 0:00	↑
Req Pos: SERVICE	
Motor: ON Sw:OPEN	
Trbn: 000 Gals: 0	↓

The 3 digits after “Trbn:” indicate water meter operation as follows.

000 (steady) = conditioned water not in use...no flow through the meter.

- open a nearby **conditioned water faucet** -

000 to 151 (continual) = repeats display for each gallon of water passing through the meter.

If you don't get a reading in the display, check the turbine connection to the electronic box. If the connection is okay and good contact is made, pull the sensor from the valve outlet port. Pass a small magnet back and forth in front of the sensor. You should get a reading in the display. If you get a reading, unhook the in and out plumbing and check the turbine for binding.

NOTE: The position switch is closed when the plunger is depressed, open when extended.

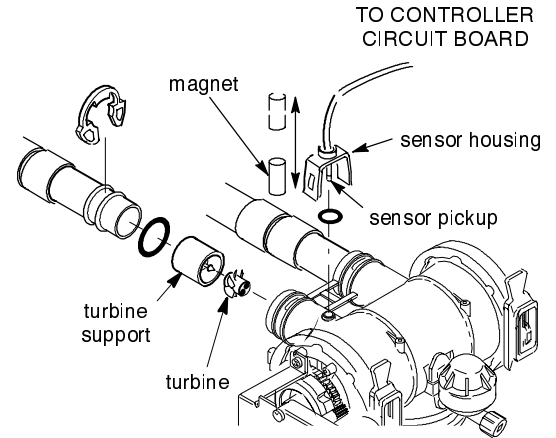

MAINTENANCE

TROUBLESHOOTING, MANUAL ADVANCE REGENERATION CHECK

This check verifies proper operation of the gear-motor, brine tank fill, brine draw, regeneration flow rates, and other controller functions. *Always make the initial checks, and the manual initiated diagnostics first.*

NOTE: A steady time (not flashing) must show in the display.

1. Use the recharge button to manually advance the valve into each cycle and check the various valve cycles. Move the cursor next to the tank and press the Recharge button. The valve will start the sequence for recharge. Press the Recharge button to advance the valve through each position.

>EXIT
Online / Offline
Recharge Now
Recharge Tonight

FILL: Remove the brinewell cover and, using a flashlight, observe fill water entering the tank.

a. If water does not enter the tank, look for an obstructed nozzle and venturi, fill flow control, screen(s) or brine tubing.

CAUTION: Softener must be depressurized before removing aspirator assembly.

BRINING: A slow flow of water to the drain will begin. Verify brine draw from the brine tank by shining the flashlight into the brinewell and observing a noticeable drop in the liquid level.

NOTE: Be sure water is in contact with the salt, and not separated by a salt bridge...see page 23.

- a. If the unit does not draw brine, check for...
 - ...dirty or defective nozzle and venturi, pages 23 & 24
 - ...restriction in valve drain, causing a back-pressure (bends, kinks, elevated too high, etc.)
 - ...obstruction in brine valve or brine tubing
 - ...inner valve failure (obstructed or defective o-ring seals, rotor or disc)

BACKWASH: Look for a fast flow of water from the drain.

a. If flow is slow, check for a plugged top distributor screen, internal riser pipe, backwash flow controls, drain piping, fouled resin bed, etc.

FAST RINSE: Again look for a fast drain flow. Allow the unit to rinse for several minutes to flush out any brine that may remain from the brining cycle test.

2. To return the valve to service position, press Recharge button once again.

Note: On multiple tank systems, the first tank advances to service before the second tank then manually advances to fill and all other cycles.

MANUAL ADVANCE REGENERATION CHECK

This check verifies proper operation of the motor, brine tank fill, brine draw, regeneration flow rates, and other controller functions. **ALWAYS MAKE THE INITIAL CHECKS, AND THE MANUAL INITIATED DIAGNOSTICS.**

NOTE: The faceplate display must show a steady time (not flashing).

1. Press the RECHARGE button and hold in for 3 seconds. RECHARGE begins to flash as the valve enters the fill cycle of regeneration. Remove the brinewell cover and, using a flashlight, observe fill water entering the tank.

a. If water **does not** enter the tank, look for an obstructed nozzle and venturi, fill flow plug, brine tubing or brine valve.

2. After observing fill, press the RECHARGE button to move the valve into brining*. A slow flow of water to the drain will begin. Verify brine draw from the brine tank by shining a flashlight into the brinewell and observing a noticeable drop in liquid level.

NOTE: Be sure a salt bridge is not preventing water from contacting salt.

a. If the softener does not draw brine...

...nozzle and venturi dirty or defective (page 23 or 24).

...nozzle and venturi not seated on gasket, or gasket defective.

...restriction in valve drain, causing back pressure (bends, kinks, elevated too high, etc., see installation step 5).

...obstruction in brine valve, or brine tubing (see repair parts pages 34 or 36).

...inner valve failure (obstruction in disc, wave washer defective, etc.)

NOTE: If water system pressure is low, an elevated drain hose may cause back pressure, stopping brine draw.

3. Again press RECHARGE to move the valve into backwash. Look for a fast flow of water from the drain hose.

a. An obstructed flow indicates a plugged top distributor, backwash flow plug, or drain hose.

4. Press RECHARGE to move the valve into fast rinse. Again look for a fast drain flow. Allow the softener to rinse for a few minutes to flush out any brine that may remain in the resin tank from the brining cycle test.

5. To return to valve to service, press RECHARGE once.

OTHER SERVICE

HARD WATER BYPASS (hard water “bleeds” into conditioned water supply).

1. Defective inlet disc, seal or wave washer (see key nos. 8, 9 and 10, page 32).
2. Missing or defective o-ring(s) at resin tank to valve connection (see key no. 3 or 4, page 31).

WATER LEAKS FROM DRAIN HOSE (during service).

1. Defective inlet disc, seal or wave washer (see key nos. 8, 9 and 10, page 32).
2. Defective o-ring on inlet disc shaft (see key no. 11, page 32).
3. Defective outlet disc, seal or wave washer (see key nos. 10, 36 and 37, page 32).

WATER HAS SALTY TASTE

1. House water pressure low (adjust pump if well system).
2. Partially restricted valve drain hose, top distributor, backwash flow plug, resin tank internal riser or bottom distributor.

REPAIR PARTS . . . RESIN TANK ASSEMBLIES

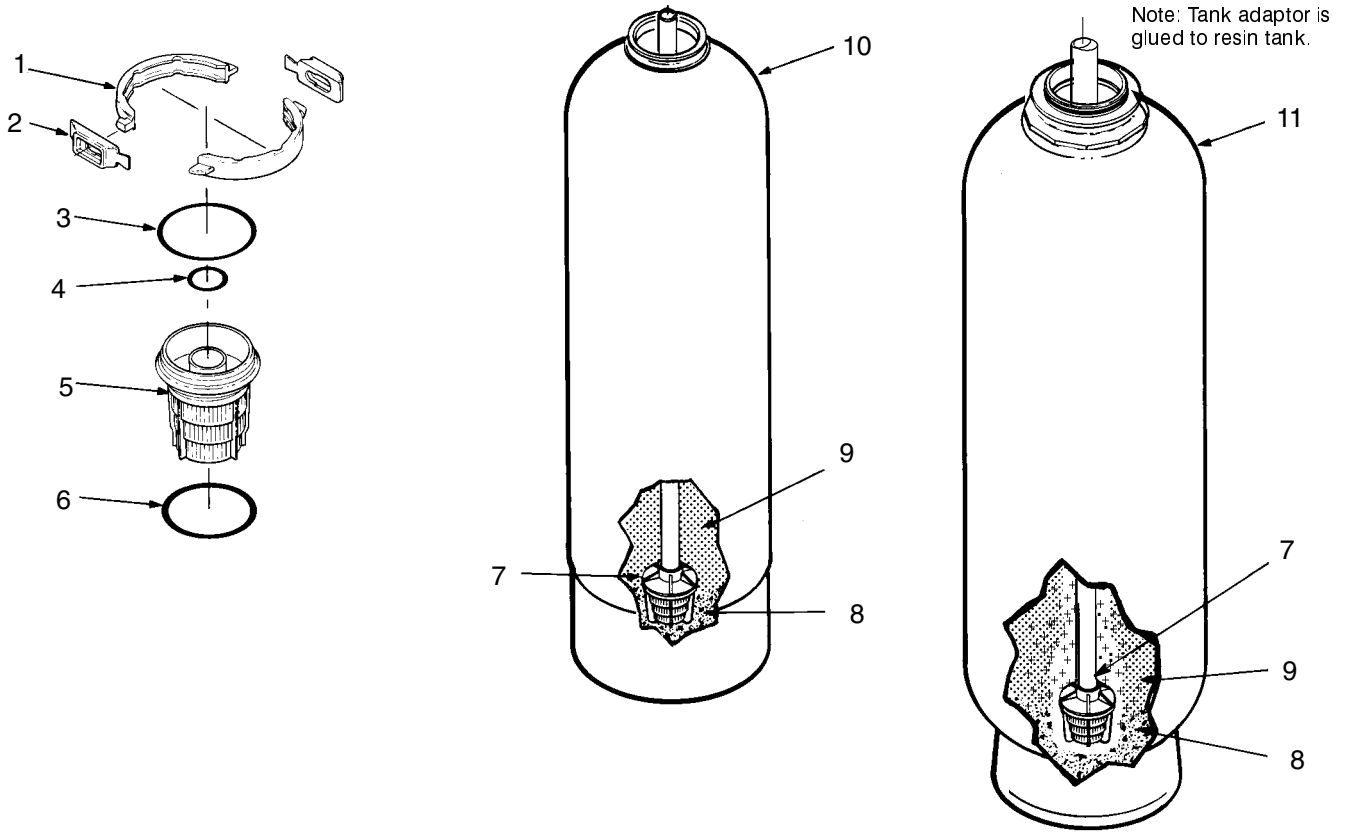

KEY NO.	PART NUMBER	DESCRIPTION
1	7176292	Clamp Section (2)
2	7088033	Clamp Retainer (2)
3	7133529	O – Ring, 2–7/8" I.D. x 3–1/4" O.D.
4	7133480	O – Ring, 13/16" I.D. x 1–1/16" O.D.
5	7077870	Top Distributor
6	7133503	O – Ring, 2–3/4" I.D. x 3" O.D.
7	7127895	Rep'l Bottom Distributor ●
8	7124415	Gravel, Fine – 17 lbs. ★
	7124423	Gravel, Fine – 50 lbs. ★
	7127073	Gravel, Medium – 50 lbs. ★
	4104600	Gravel, Coarse – 50 lbs. ★
9	0502272	Resin, 1 cu. ft. ★
10	7172638	Rep'l Resin Tk – Models EWS050 & EWS070
	7172646	Rep'l Resin Tk – Models EWS100 & EWS130
11	7141409	Rep'l Resin Tk – All other models ■

- Be sure to check length...page 6.
- ★ See page 24 for amount required.
- Includes key nos. 1 through 7.

OPTIONAL FOAM TANK WRAPS	
7129245	Models EWS050 & EWS070
7129253	Models EWS100 & EWS130
7153472	Models EWS190, EWS250 & EWS320

ACCESSORIES	
7242996	Remote Monitor Kit
7238735	Error Indicator
7238727	Controller Extension Cable, 20'

REPAIR PARTS . . . VALVE ASSEMBLY

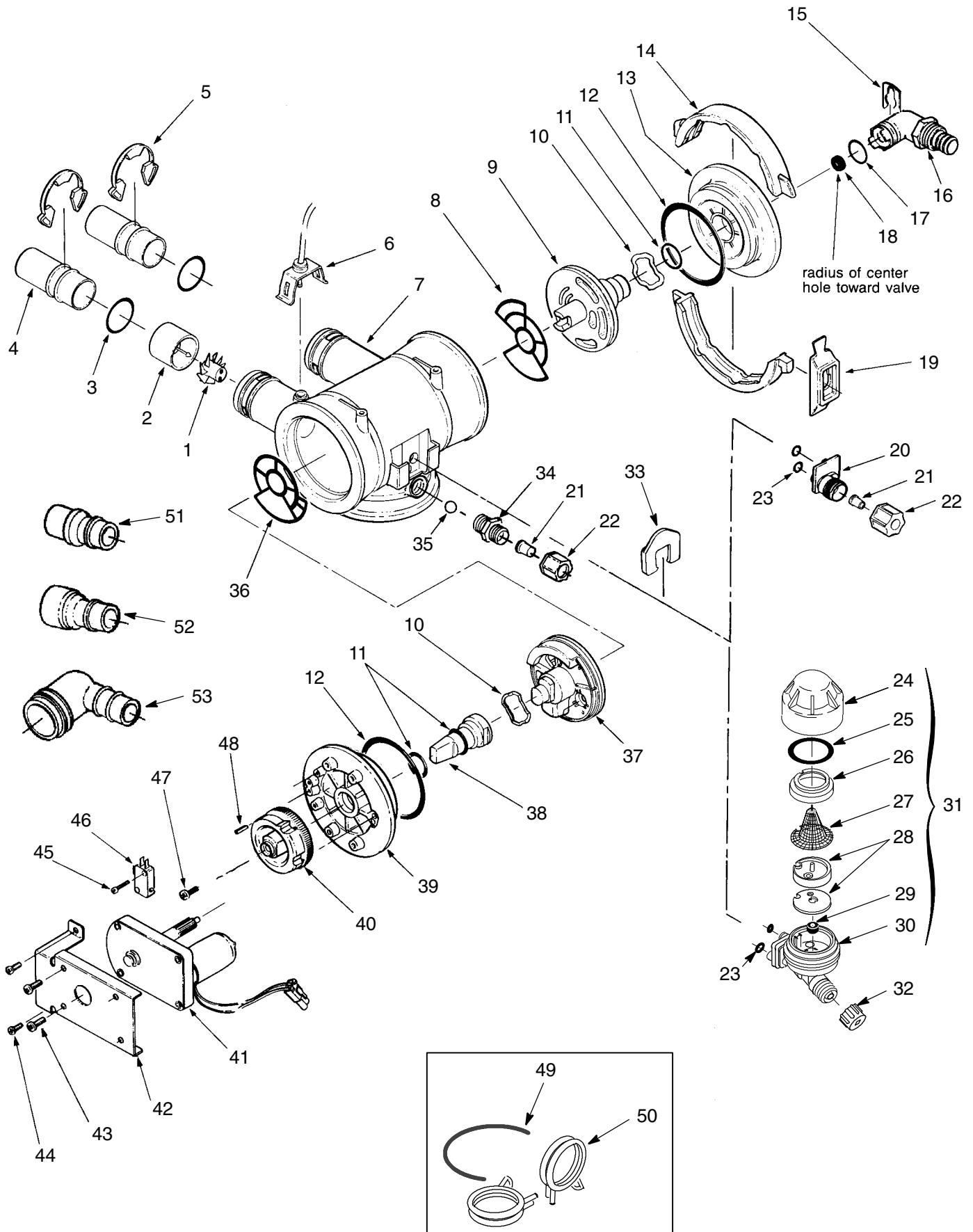

REPAIR PARTS . . . VALVE ASSEMBLY

KEY NO.	PART NUMBER	DESCRIPTION
1	7123061	Turbine Assembly
2	7119177	Turbine Mounting Assembly
3	7170262	O – ring, 1.109" I.D. x 1.387 (2)
4	7077642	Copper Tube, 1" (2)
	7129203	Adaptor Fitting, 1 – 1/2" – OPTIONAL
5	7089306	Clip Retainer (2)
6	7234854	Controller Cable/Sensor Housing
7	7159949	Disc Valve Housing – EWS050 & EWS070 models
	7159957	Disc Valve Housing – all other models
8	7139452	Inlet End Seal ■
9	7214286	Inlet Disc ■
10	7058216	Wave Washer (2)
11	7133472	O – ring, 3/4" I.D. x 15/16" (3) ■
12	7133529	O – ring, 2 – 7/8" I.D. x 3 – 1/4" (2)
13	7077498	Inlet End Cap
14	7176292	Clamp Section (4, – 2 not shown)
15	7142942	Clip
16	7108100	Drain Hose Adaptor – EWS050 & EWS070 models
	7141239	Drain Hose Adaptor – all other models
17	7139478	O – ring, 5/8" I.D. x 13/16"
18	1110700	Flow Washer, 3 gpm – EWS050 & EWS070 models
	0509537	Flow Washer, 7 gpm – EWS100 & EWS130 models
	1110900	Flow Washer, 10 gpm – EWS190, EWS250 & EWS320 models
19	7088033	Clamp Retainer (4, – 3 not shown)
20	7128760	Adaptor, 3/8" Tube
21	7131349	Tubing Insert (2)
22	9003203	Nut, 3/8" Tube (2)
23	7139460	O – ring, 1/4" I.D. x 3/8" (2)
24	7199729	Cap ⚡
25	7170262	O – ring, 1 – 3/16" I.D. x 1 – 3/8" ⚡

■ Parts included in Disc Kit, Part No. 7116739.

⚡ Used on EWS050 and EWS070 models only.

◆ Includes Key Nos. 24 through 30.

KEY NO.	PART NUMBER	DESCRIPTION
26	7167659	Screen Support ⚡
27	7146043	Screen ⚡
28	7114533	Nozzle & Venturi – Gasket Kit ⚡
	7204362	Gasket only
29	1148800	Flow Plug, .3 gpm ⚡
30	7081104	Housing, Nozzle & Venturi
31	7085247	Nozzle & Venturi Assembly ⚡ ◆
32	1202600	Nut Ferrule ⚡
33	7081201	Clip
34	7147992	Connector
35	7075632	Ball, Check
36	7139444	Outlet End Seal ■
37	7223196	Outlet Disc ■
38	7091329	Driver, Outlet Disc
39	7159965	Outlet End Cap
40	7147730	Cam & Gear
41	7147049	Motor
42	7147057	Motor Bracket
43	7168524	Screw, #10 – 32 x 5/16" (3, 1 not shown)
44	7103972	Screw, #8 – 18 x 7/16" (2)
45	7140738	Screw, #4 – 24 x 3/4"
46	7145186	Switch
47	7203104	Screw, #8 – 18 x 9/16"
48	7140746	Expansion Pin
49	7207726	Ground Wire
50	7163427	Ground Clamp (2)

Optional Inlet/Outlet Fittings		
51	7104546	PVC Nipple (2)
52	7129211	Adaptor Fitting, 1 – 1/2" (2)
53	7120259	Elbow (2)

REPAIR PARTS . . . BRINE TANKS MODELS EWS050 & EWS070

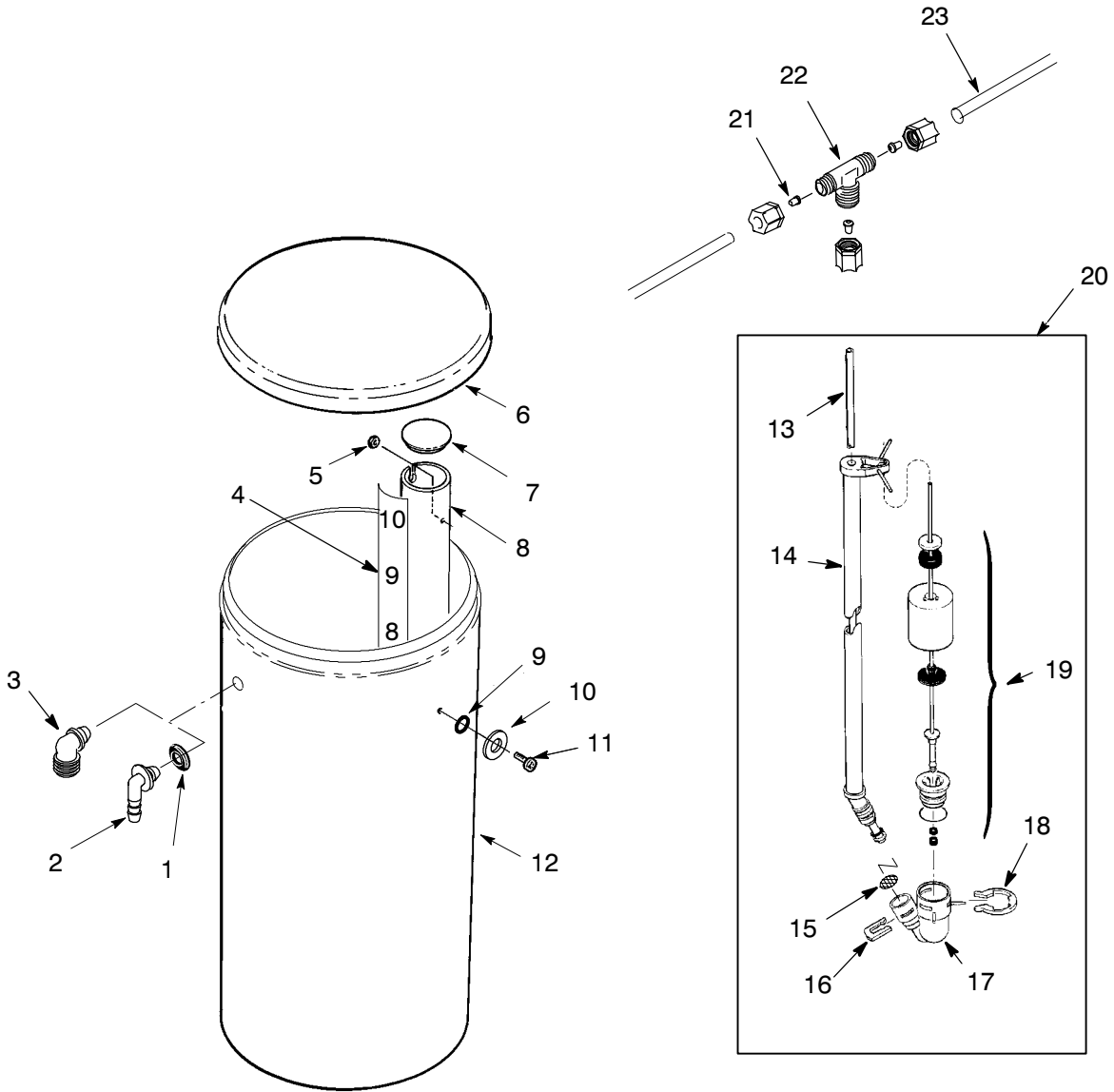

**REPAIR PARTS . . . BRINE TANKS
MODELS EWS050 & EWS070**

KEY NO.	PART NO.	DESCRIPTION
1	9003500	Grommet, 340# Brine Tank
2	1103200	Tubing Adaptor, 340# Brine Tank
3	0523819	Drain Elbow, 700# Brine Tank
4	7243853	Decal, Brinewell
5	7082150	Nut, 1/4" – 20, 340# Brine Tank
–	0120375	Nut, 1/4" – 20, 700# Brine Tank
6	7180437	Brine Tank Cover, 340# Brine Tank
7	7155115	Brinewell Cover, 340# Brine Tank
–	7222051	Brinewell Cover, 700# Brine Tank
8	7100819	Brinewell, 340# Brine Tank
–	0980062	Brinewell, 700# Brine Tank
9	7003847	O – ring, 340# Brine Tank
10	0507007	Washer, 700# Brine Tank
11	0900296	Screw, 1/4" – 20 x 5/8"
12	7112612	Brine Tank, 340# Brine Tank
–	7227019	Brine Tank, w/cover, 700# Brine Tank

KEY NO.	PART NO.	DESCRIPTION
13	7113016	Tube Assembly, Brine Valve
14	7221746	Brine Tube
15	7131365	Screen
16	7080653	Clip
17	7092252	Brine Valve Body
18	1205500	Clip
19	7221754	Float, Stem & Guide Assembly
20	7220928	Brine Valve Asm. (includes 13 – 19)
MULTIPLE TANK SYSTEMS		
21	7094979	Insert, Tubing (3 req'd)
22	7056612	Tee, Tubing (5/16")
23	7161815	Tubing, 5/16" O.D. x 20'
	7161776	Tubing, 5/16" O.D. x 100'

REPAIR PARTS . . . ALL OTHER BRINE TANKS

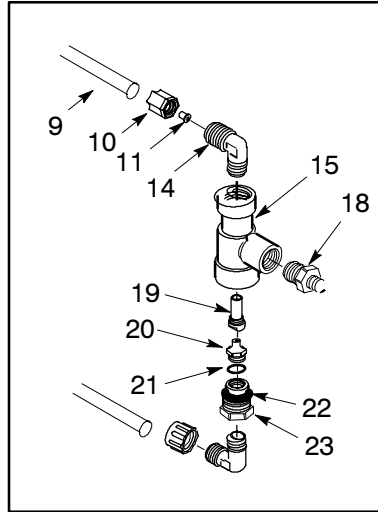
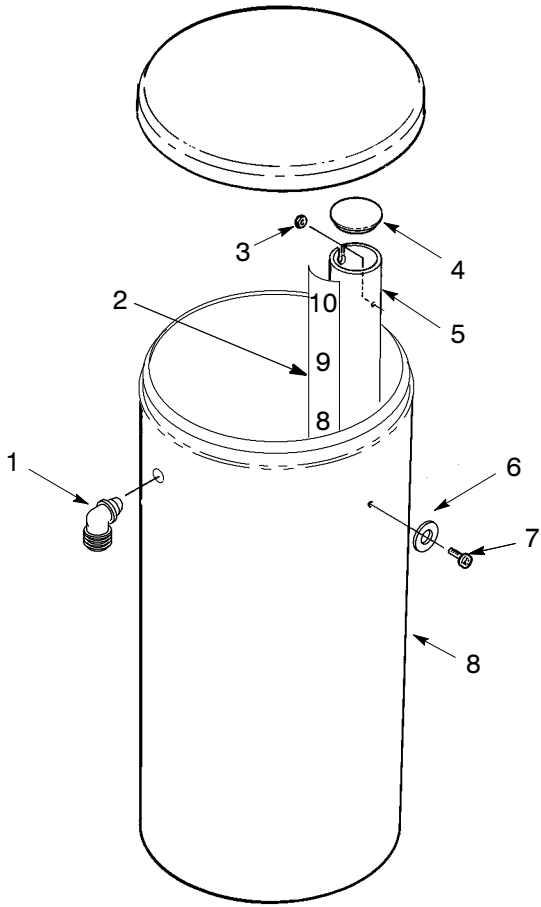

SINGLE SYSTEMS

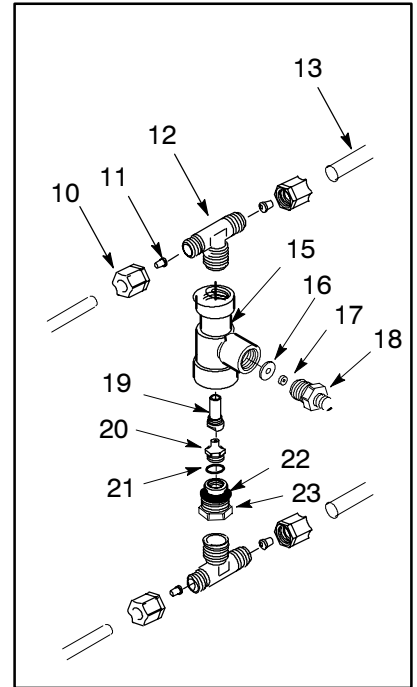

MULTIPLE SYSTEMS

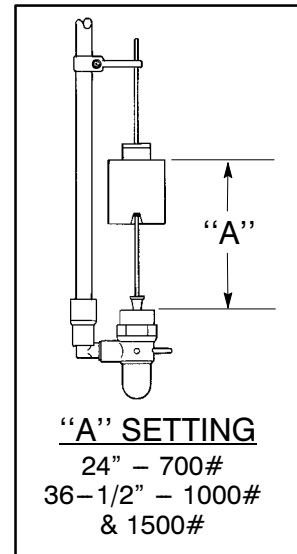
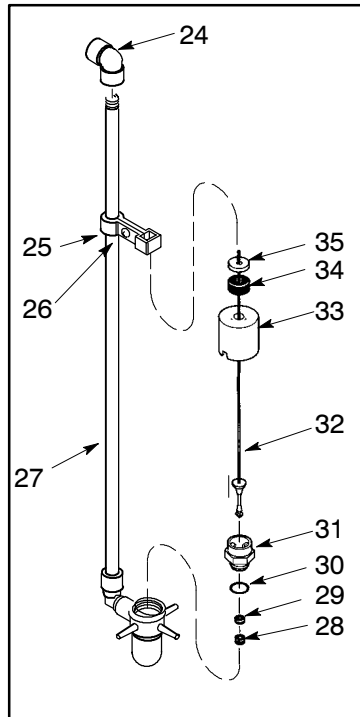



REPAIR PARTS . . . ALL OTHER BRINE TANKS

KEY NO.	PART NO.	DESCRIPTION
1	0523819	Drain Elbow
2	7243853	Decal, Brinewell
3	0120375	Nut, 1/4" – 20
4	7222051	Brinewell Cover
5	0980062	Brinewell, 700# Brine Tank
–	0980067	Brinewell, 1000# & 1500# Brine Tank
6	0507007	Washer
7	7178634	Screw, 1/4" – 20 x 5/8"
8	7227019	Brine Tank (w/cover), 700# Brine Tank
–	7227027	Brine Tank (w/cover), 1000# Brine Tk
–	7227035	Brine Tank (w/cover), 1500# Brine Tk
9	7168435	Tubing, 3/8" x 5–1/2' (2)
10	9003203	Nut, 3/8" (2)
11	7131349	Tubing Insert (2)
12	7226966	Tee, 3/8 NPT x 3/8" Tube (2)
13	7092781	Tubing, 3/8" x 10' (4)
14	9004503	Elbow (2)
15	1109600	Housing, Nozzle & Venturi
16	1135200	Seal Disc
17	1148800	Flow Plug, 700# Brine Tank
–	7128396	Flow Plug, 1000# & 1500# Brine Tank
18	7028889	Bushing, 1/2" NPT, 700# Brine Tank
–	7128401	Bushing, 1/2" NPT, 1000# & 1500# Brine Tank
19	7126645	Venturi, Almond, 700# Brine Tank
–	7127772	Venturi, Gray, 1000# & 1500# Brine Tk

KEY NO.	PART NO.	DESCRIPTION
20	7126637	Nozzle, White, 700# Brine Tank
–	7127764	Nozzle, Gray, 1000# & 1500# Brine Tk
21	0900060	O–ring, 7/16" x 9/16"
22	7170327	O–ring, 5/8" x 13/16"
23	1109700	Nozzle Housing
24	9007700	Elbow, 1/2" NPT
25	1112200	Float Rod Guide
26	9006071	Screw, #6 – 20 x 7/8"
27	7234595	Rep'l Riser Pipe & Elbow Assembly
28	0516924	Retainer, Bottom Seal
29	0516211	Bottom Seal
30	0900186	O–ring, 7/8" x 1"
31	0517030	Brine Valve Nut
32	2174500	Float Rod & Stem
33	2220300	Float Assembly
34	0513860	Float Stop
35	7168647	Ceramic Washer
–	7231254	Brine Valve Asm. (incl. key nos. 15 – 35), 700# Brine Tank
–	7231262	Brine Valve Asm. (incl. key nos. 15 – 35), 1000# & 1500# Brine Tank
–	7161815	Tubing, 3/8" O.D. x 20'
–	7161776	Tubing, 3/8" O.D. x 100'

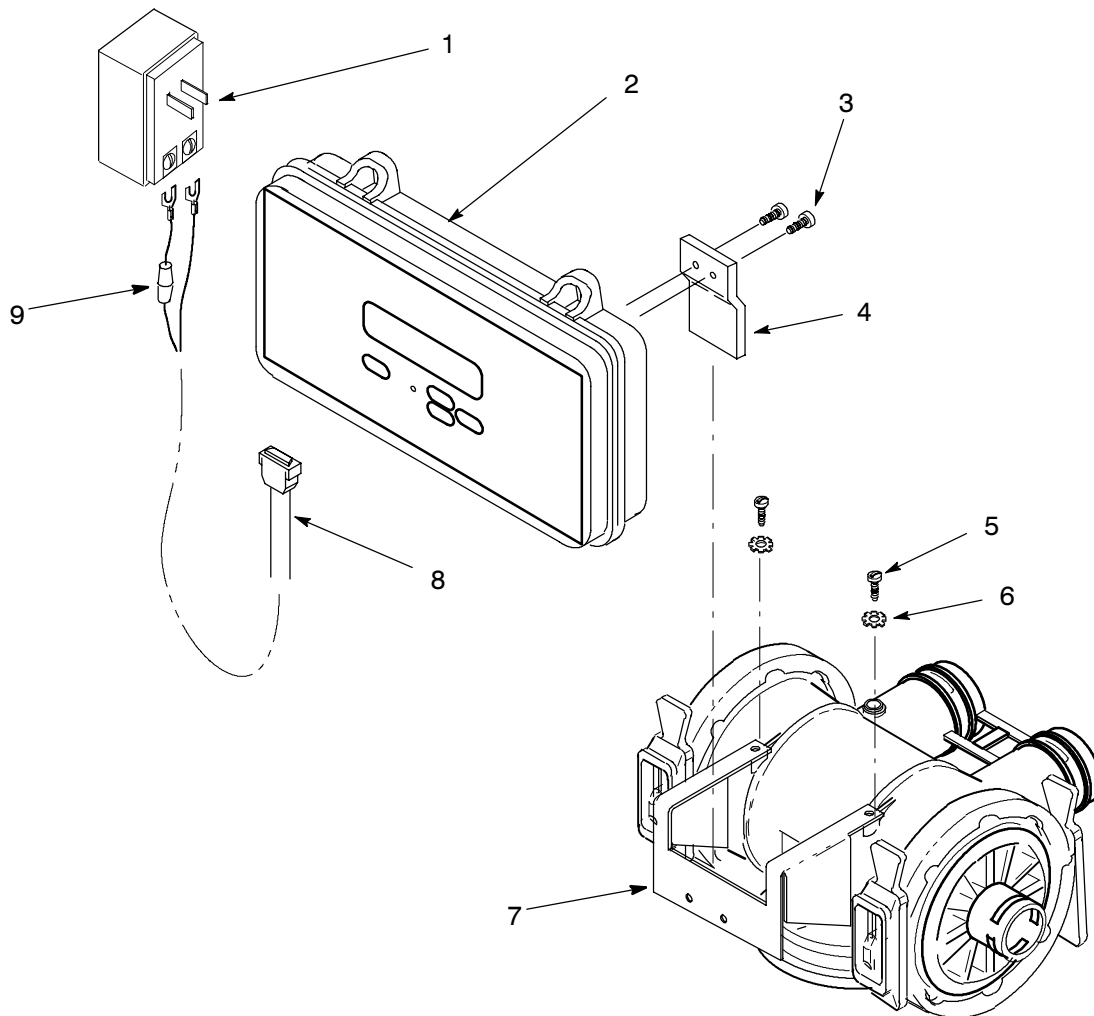
REPAIR PARTS . . . CONTROLLER and ASSOCIATED PARTS



KEY NO.	PART NUMBER	DESCRIPTION
1	7084550	Transformer, 24V – 25VA
2	7239854	Control Box
3	9006029	Screw, #6–20 x 5/16", 2 req'd
4	0502080	Bracket
5	7103972	Screw, #8–18 x 7/16", 2 req'd
6	0811297	Lockwasher, 2 req'd
7	7246047	Bracket
8	7234846	Power Cable
9		Fuse, AGC 3A 250V, Purchase locally, replace with same type and value only. 

NO-BYPASS KIT, #7128825

1. Make two assemblies, like the one shown in Figure 17, turning the nut on until snug and all parts are held together.

CAUTION: IF THE SYSTEM IS ALREADY IN SERVICE, BE SURE TO TURN OFF WATER TO THE UNIT, AND TO RELIEVE PRESSURE BY OPENING A FAUCET, OR ADVANCING THE VALVE INTO A RECHARGE POSITION.

2. Remove the valve, outlet side clamp retainers and clamps. With motor attached, pull the outlet end cap from the valve. Remove the o-ring seal, wave washer and outlet disc, as shown in Figure 18.

3. Looking at Figure 19, place one of the plug assemblies into one of the two indicated ports and begin tightening the screw. **BE SURE THE SCREW HEAD IS FULLY INSIDE THE PORT SO IT WILL NOT INTERFERE WITH THE OUTLET DISC** (see cut away). Tighten the screw until the rubber seals are spread tightly against the port walls, and the screw will no longer turn.

4. Repeat step 3 using the remaining plug assembly in the other port.

5. Reassemble the valve.

Figure 17

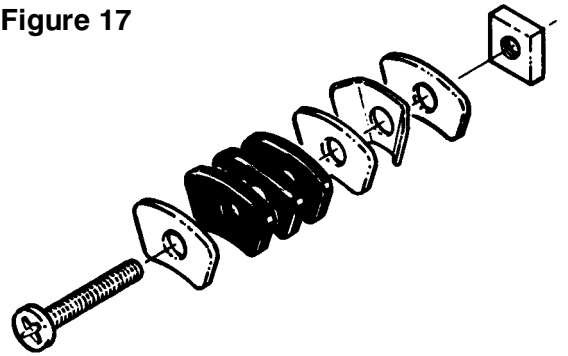

Figure 18

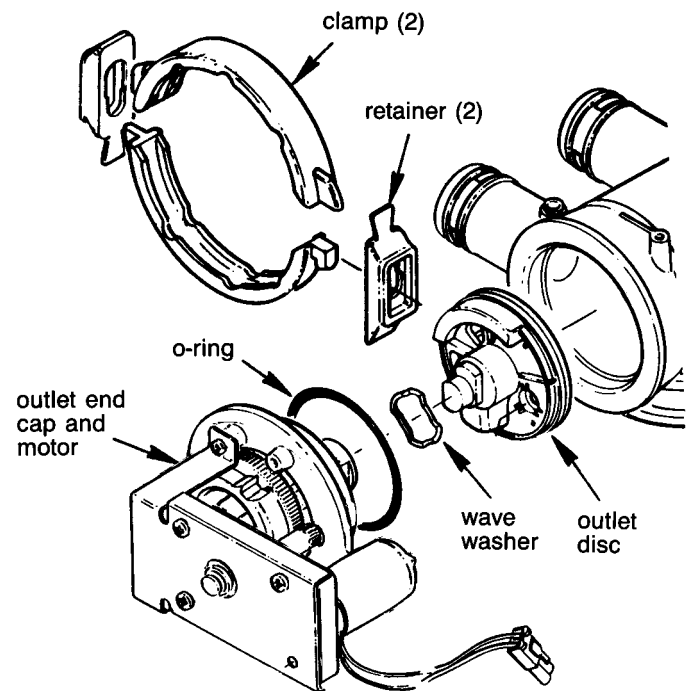

Figure 19

