

OWNERS MANUAL

How to maintain and operate your
EcoWater birm filter with air injected assembly

.....

ECOWATER
S Y S T E M S®



MODELS
ETF AIIF9-115
& ETF AIIF9-220

NOTE: Refer to manual # 7220415 for
information on all models with an **AC**
(alternating current) valve drive motor.

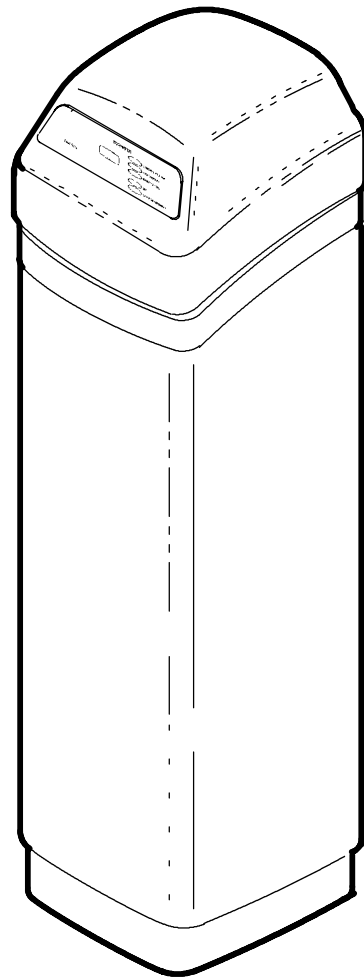

UNPACKING

EcoWater Air Injected Iron Filters are shipped from the factory in four master cartons consisting of ...

- ...Mineral tank and adaptor assembly
- ...Controller assembly (includes this manual)
- ...Birm packed ♦
- ...Quartz packed

Thoroughly check the filter for possible shipping damage and parts loss. Also inspect and note any damage to the shipping cartons. Notify the transportation company if damage is present. EcoWater is not responsible for in-transit damages.

Remove and discard (RECYCLE) all packing materials. Filter assembly instructions are on pages 5 & 6.

TABLE OF CONTENTS

	PAGE
Unpacking	2
Warranty-Safety Guides	3
Specifications - Dimensions	4
Filter Assembly	6
Typical Installation Drawing	7
Where To Install The Filter	8
Installation Steps	9 - 11
Plumb In and Out Pipes	9
Connect Valve Drain Hose	10
Connect Air Pump	11
Electrical Connections	11
Pressurizing System - Checking Work For Leaks	11
Program Filter Timer	12- 13
Timer Features	13- 14
Service Information	18- 19
Repair Parts	20- 23

♦ **Note:** The birm will initially retain large amounts of air. If it is backwashed before the air is removed, the valve may get plugged with birm particles, or particles may get flushed to the drain.

To remove the air, soak the birm in water for 24 hours prior to loading into the tank, or load the dry birm into the tank, but do not allow the filter to regenerate until the birm has been wetted for at least 24 hours.

EcoWater Systems, Inc.
Advantage Warranty
Series ETF AIIF Water System

Congratulations! You have just purchased the highest quality water conditioning product on the market. To register your warranty, complete the enclosed Warranty Registration Card and mail it within 30 days of purchase.

To whom is this warranty extended?

EcoWater Systems, Inc. warrants its products to the original owner and guarantees that the products will be free from defects in materials and workmanship from the original date of installation.

How does my warranty work?

If, during the respective warranty period, a part proves, after inspection by EcoWater, to be defective, EcoWater will, at its sole option repair or replace that part at no charge, other than normal shipping and installation charges.

What is covered by the warranty?

EcoWater systems, Inc. guarantees that,

for the LIFETIME of the original owner, the MINERAL TANK will not rust, corrode, leak, burst, or in any other manner fail to perform its proper function and that,

for a period of FIVE (5) YEARS after installation, the VALVE BODY will be free of defects in materials and workmanship and will perform its proper function and that,

for a period of THREE (3) YEARS after installation, the ELECTRONIC FACEPLATE will be free of defects in materials and workmanship and will perform its normal functions and that,

for a period of ONE (1) YEAR after installation, ALL OTHER PARTS will be free of defects in materials and workmanship and will perform their normal functions.

How do I obtain local service?

Should you need service, your local, independent EcoWater Dealer is only a phone call away.
PHONE: _____

If I need a part replaced after the factory warranty expires, is that part warranted?

Yes, EcoWater Systems, Inc. warrants FACTORY REPAIRS as well as all REPLACEMENT PARTS for a period of 90 DAYS.

Are any additional warranties available?

We are pleased to say, YES! EcoWater Systems, Inc. offers an EXTENDED, PARTS ONLY WARRANTY for the ELECTRONICS portion of your product. This warranty is called the "Perfect Ten" and extends the three year warranty on the electronic FACEPLATE, WIRING HARNESS, DRIVE MOTOR, TRANSFORMER, POWER CORD, SENSOR HOUSING, and MICRO SWITCHES to a total of TEN YEARS from the date of original installation. Should your local dealer not offer this warranty, you may contact the factory for additional information.*

General Provisions

The above warranties are effective provided the water conditioner is operated at water pressures not exceeding 125 psi, and at water temperatures not exceeding 120°F; provided further that the water conditioner is not subject to abuse, misuse, alteration, neglect, freezing, accident or negligence; and provided further that the water conditioner is not damaged as the result of any unusual force of nature such as, but not limited to, flood, hurricane, tornado or earthquake. EcoWater Systems, Inc., is excused if failure to perform its warranty obligations is the result of strikes, government regulation, materials shortages, or other circumstances beyond its control.

To obtain warranty service, notice must be given, within thirty (30) days of the discovery of the defect, to your local EcoWater Systems dealer.

*THERE ARE NO WARRANTIES ON THE WATER CONDITIONER BEYOND THOSE SPECIFICALLY DESCRIBED ABOVE. ALL IMPLIED WARRANTIES, INCLUDING ANY IMPLIED WARRANTY OF MERCHANTABILITY OR OF FITNESS FOR A PARTICULAR PURPOSE, ARE DISCLAIMED TO THE EXTENT THEY MIGHT EXTEND BEYOND THE ABOVE PERIODS. THE SOLE OBLIGATION OF ECOWATER SYSTEMS, INC. UNDER THESE WARRANTIES IS TO REPLACE OR REPAIR THE COMPONENT OR PART WHICH PROVES TO BE DEFECTIVE WITHIN THE SPECIFIED TIME PERIOD, AND ECOWATER IS NOT LIABLE FOR CONSEQUENTIAL OR INCIDENTAL DAMAGES. NO ECOWATER DEALER, AGENT, REPRESENTATIVE, OR OTHER PERSON IS AUTHORIZED TO EXTEND OR EXPAND THE WARRANTIES EXPRESSLY DESCRIBED ABOVE.

Some states do not allow limitations on how long an implied warranty lasts or exclusions or limitations of incidental or consequential damage, so the limitations and exclusions in this warranty may not apply to you. This warranty gives you specific legal rights, and you may have other rights which vary from state to state. This warranty applies to consumer-owned installations only.

SAFETY GUIDES

Follow the installation instructions carefully. Failure to install the filter properly **voids the warranty.**

Before you begin installation, read this entire manual. Then, obtain all the materials and tools you will need to make the installation.

Check local plumbing and electrical codes. The installation must conform to them.

NOTE: Codes in the state of Massachusetts require installation by a licensed plumber. For installation, use plumbing code 248-CMR of the Commonwealth of Massachusetts.

Use only lead-free solder and flux for all sweat-solder connections, as required by state and federal codes.

Use care when handling the filter. Do not turn upside down, drop, or set on sharp protrusions.

Do not locate the filter where freezing temperatures occur. Do not attempt to filter water over 120°F. **Freezing, or hot water damage voids the warranty.**

Avoid installing in direct sunlight. Excessive sun heat may cause distortion or other damage to non-metallic parts.

The filter requires a **minimum water flow of 7 gallons per minute** at the inlet for *backwash*.

Maximum allowable inlet water pressure is 60 psi. Use a pressure reducing valve if necessary. Be sure the addition of a pressure reducing valve will not reduce the flow to less than the 7 gpm needed for backwash.

This filter controller works on 24 volt-60 hz electrical power only. Be sure to use the included transformer and plug it into a nominal 120v, 60 cycle household outlet that is grounded and properly protected by an over current device such as a circuit breaker or fuse. If transformer is replaced, use only the authorized service, class II, 24 volt, 10 va transformer. The air pump must be separately wired to 110V or 220V service.

This system is not intended to be used for treating water that is microbiologically unsafe or of unknown quality without adequate disinfection before or after the system.

BIRM FILTER WITH AIR INJECTION ASSEMBLY

Filter Type *Oxidizing*
 Type of Mineral *Birm*
 Amount of Mineral *1.25 cu ft*
 Amount of Gravel *17 lbs*
Maximum Water Supply
 Pressure *60 psi*
 Recommended Type Water
 Supply *Well System*
 Maximum Water Temperature . *120 °F*
 Minimum Water Supply pH ... *7.0*
Maximum Service Flow *5.0 gal per min*
Minimum Backwash Flow ① .. *7.0 gal per min*
 Minimum In-Out Pipe Size ... *3/4 in.*
 Electrical: Filter Timer *24V-60Hz*
 Air Pump *220V-60Hz,*
 or 115V-60Hz

Some feed water with high iron concentrations, or low pH may require limited service flows or a neutralizer filter before the system.

IRON CONC.	MAXIMUM SERVICE FLOW RATE OF IRON FILTER			
	20 PPM	4	4	4
15 PPM	4	4	4	5
10 PPM	4	4	4	6
5 PPM	4	4	5	7
2 PPM	4	4	6	8
	6.5	7.0	7.5	8.0
	pH			
	Neutralizer needed			

Contaminant Removal Limitations:

- ☞ up to 10 ppm iron* and 3ppm hydrogen sulfide at pH of 7.0 and higher
- ☞ up to 20 ppm iron* and 2ppm hydrogen sulfide at pH of 8.0 and higher
 - ☞ up to 2 ppm manganese at pH of 8.5 and higher

* *except, bacterial and organically bound iron*

① **A minimum flow of 7 gpm is required for filter backwash.**

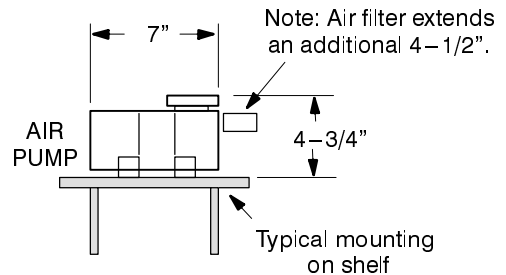
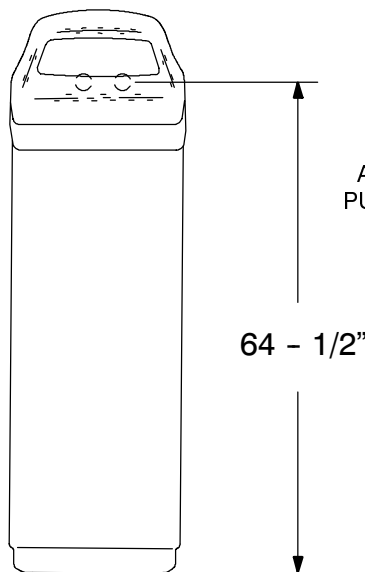
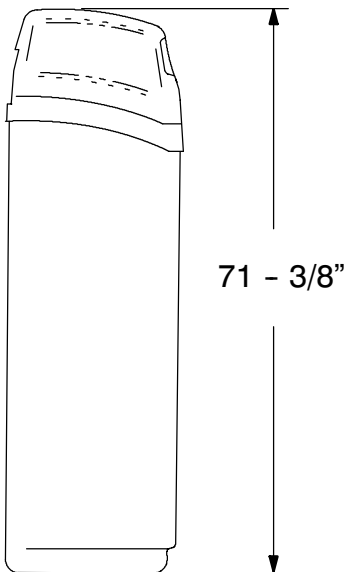
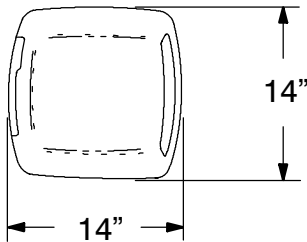

ASSEMBLE AIR INJECTOR ADAPTOR

1. Put the top end of the float into the matching port in the bottom of the adaptor and insert the pin as shown in figure 1.
2. Take a length of 1/4" tubing and push the insert (restrictor) into one end. Then, push this end of the tubing into the connector fitting installed in the check valve.
3. Take the other length of tubing and push one end into the other connector fitting on the adaptor.

FIGURE 1

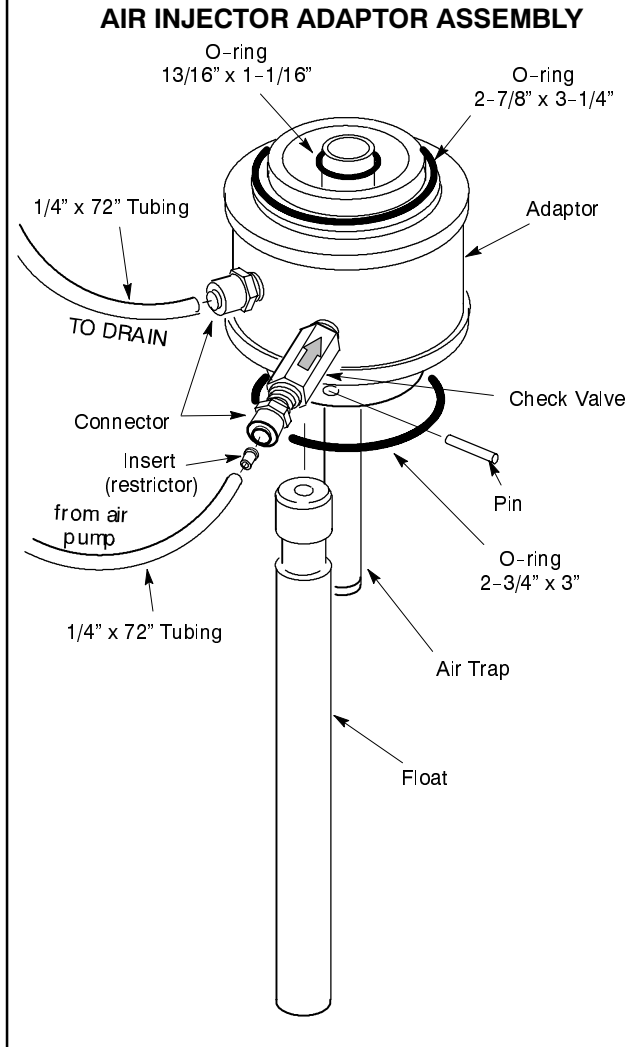

SANITIZING THE FILTER

Care is taken at the factory to keep your water filter clean and sanitary. Materials used to make the filter will not infect or contaminate your water supply, and will not cause bacteria to form or grow; however, during shipping, storage, installing and operating, bacteria could get into the filter. For this reason, sanitizing, as follows, is suggested when installing.

Pour about 1 oz. or 2 oz. of the following disinfectant into the filter.

1. Calcium hypochlorite, available in granular or tablet form, under trade names such as Perchloron or HTH.
2. Common 5.25% household bleach such as Clorox, Linco, Bo Peep, White Sail, Eagle, etc.

SANITIZING CONTINUED IN STEP 9, PAGE 11, AND STEP 2 ON PAGE 13.

FILL THE MINERAL TANK

1. Remove the shipping cap from the mineral tank.
2. Fill the tank with the gravel and birm, in that order. **Be sure the bottom distributor is centered in the tank. Do not get gravel and birm inside the distributor.**

Note: The birm will initially retain large amounts of air. If it is backwashed before the air is removed, the valve may get plugged with birm particles, or particles may get flushed to the drain.

To remove the air, soak the birm in water for 24 hours prior to loading into the tank, or load the dry birm into

the tank, but do not allow the filter to regenerate until the birm has been wetted for at least 24 hours.

INSTALL ADAPTOR ON MINERAL TANK

1. Be sure o-ring seals are lubricated and installed in place on the adaptor.
2. Be sure the tank opening is clean. Then, install the tank adaptor as shown in Figure 2. Use clamps and retainers to fasten in place.
3. Remove the controller covers and install the valve assembly, clamping in place.

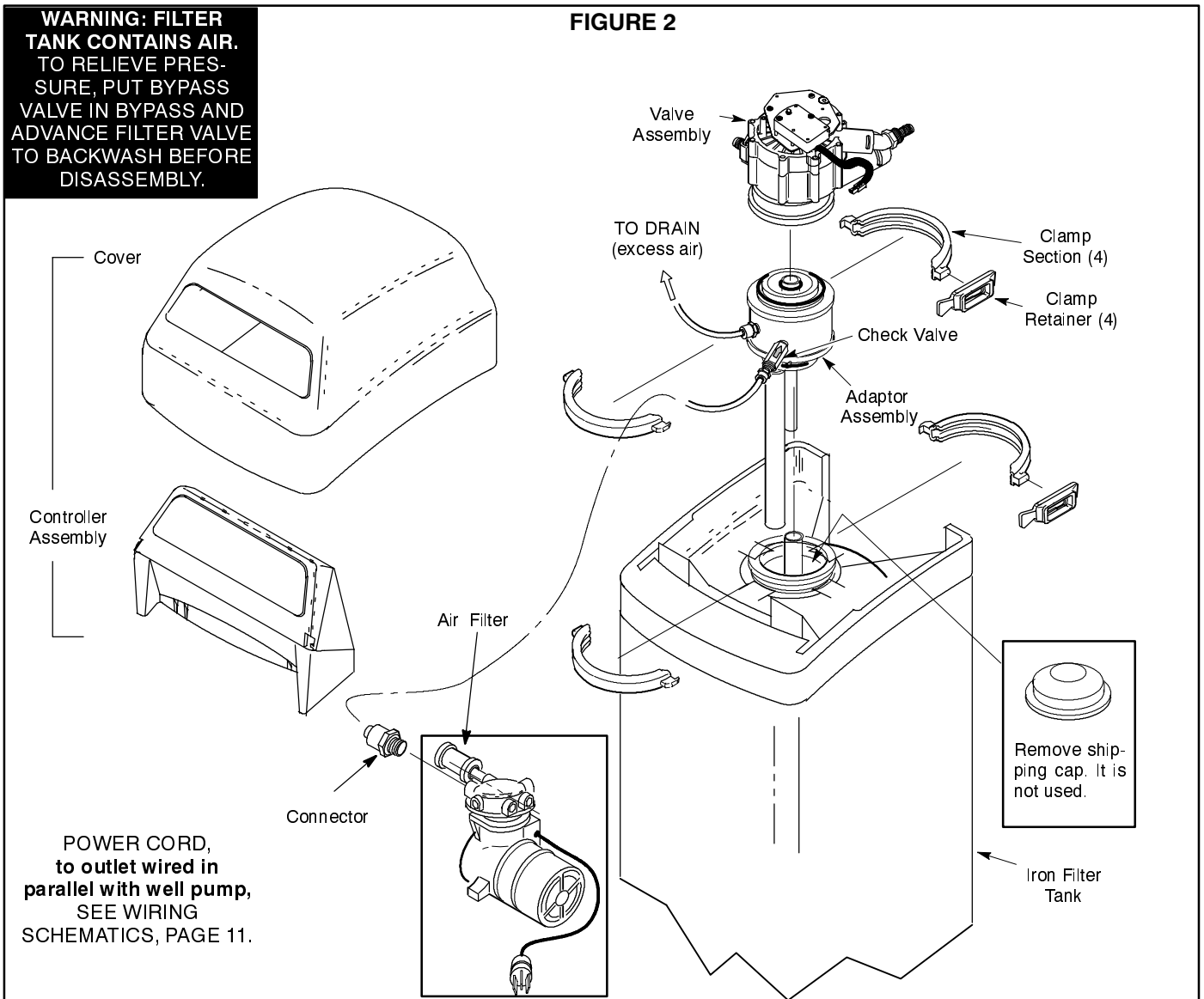
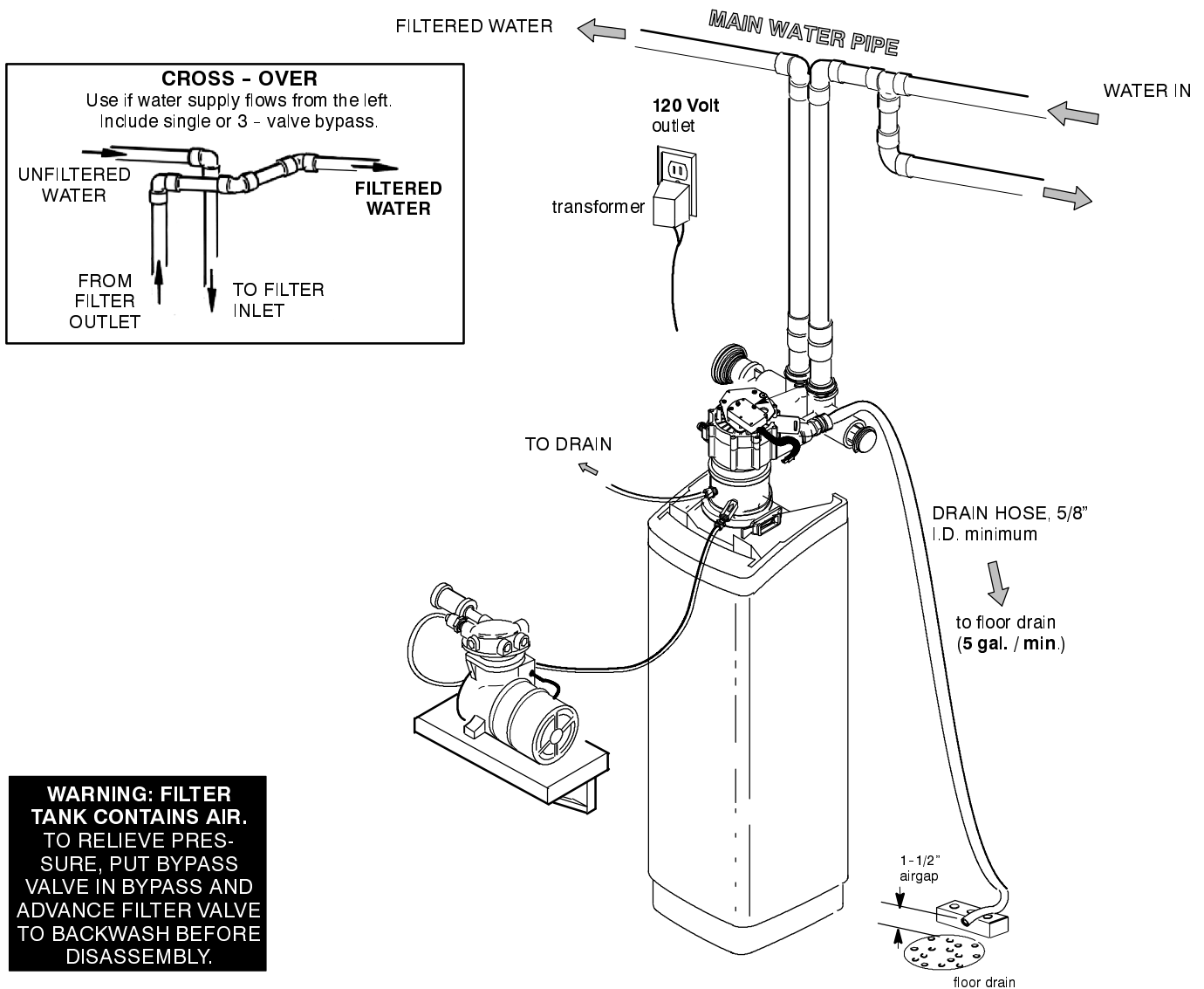

FIGURE 3 - TYPICAL FINISHED INSTALLATION



WARNING: FILTER TANK CONTAINS AIR. TO RELIEVE PRESSURE, PUT BYPASS VALVE IN BYPASS AND ADVANCE FILTER VALVE TO BACKWASH BEFORE DISASSEMBLY.



INLET - OUTLET PLUMBING OPTIONS

1. ALWAYS INSTALL either an EcoWater bypass valve, #7214383, or a 3 valve bypass system.
2. Use 1" or 3/4" (minimum) pipe and fittings.
3. Use sweat copper or threaded pipe* or PVC plastic pipe.*

*Sweat soldering is required to adapt to the fittings (1" male) supplied with the filter, or obtain approved compression adaptors. The following special fittings

are available from EcoWater. Be sure to comply with all local plumbing codes.

OPTIONAL INLET/OUTLET FITTINGS

-  — #7104546 PVC Nipple – Use in place of included copper inlet and outlet tubes.
-  — #7129211 Adaptor Fitting, 1-1/2" (2) – Use in place of included copper inlet and outlet tubes.
-  — #7120259 Elbow – Extends inlet and/or outlet in any 90° direction.

OTHER REQUIREMENTS

4. A drain is needed for regeneration discharge water. A floor drain, close to the filter is preferred. A laundry tub, standpipe, etc., are other options.

CAUTION: DRAIN WATER EXITS THE HOSE AT

TOOLS YOU MAY NEED

- common screwdriver
- cross-point screwdriver
- pliers
- tape measure

SOLDERED COPPER THREADED CPVC PLASTIC

- | | | |
|--|--------------------------|---------------------|
| • tubing cutter | • hacksaw or pipe cutter | • hacksaw |
| • propane torch | • threading tool | • adjustable wrench |
| • LEAD-FREE solder and flux | • pipe joint compound* | • solvent cement* |
| • emery cloth, sandpaper or steel wool | | • primer |

MATERIALS YOU MAY NEED

- bypass valve, or 3 valves
- pipe and fittings as required
- 5/8" I. D. minimum drain hose, either standard garden hose, or hose onto a barb fitting*

***VALVE DRAIN OPTIONS:** Flexible drain hose is not allowed in all localities (check your codes). For a rigid valve drain run, plumb according to local codes. To connect to the valve drain fitting, purchase an adaptor, garden hose thread x 5/8" (minimum) tube. Use a hacksaw to cut barbs from the fitting.

A FAST FLOW RATE, AND AT WATER SYSTEM PRESSURE. BE SURE THE HOSE IS FASTENED IN SOME MANNER TO PREVENT "WHIPPING", AND SPLASHING TO PREVENT WATER DAMAGE TO SURROUNDING AREA.

5. A 120v-60Hz, grounded electrical outlet (continuously "live" is need within 10' of the filter.

SELECT INSTALLATION LOCATION

Consider all of the following when selecting an installation location for the filter selected.

- To filter all water in the home, install the filter close to the water supply inlet. To conserve filtered water, outside faucets should remain on raw water.
- If other water conditioning equipment is installed, locate as shown in Figure 4.
- A nearby drain is needed to carry away regeneration discharge water. A floor drain is preferred, with a laundry tub, standpipe, etc., as other options (check your local codes).
- The filter works on 24 volts only. A transformer is included (FOR INDOOR USE) to reduce 120V-60 Hz house electrical power. Provide an approved, grounded outlet within 10' of the filter. The filter includes a 10' power cable for connection between the transformer and the timer.
- Position the filter at least 6" from surrounding walls, or other appliances, to allow access for servicing.
- If installing the filter in an outside location, be sure to provide protection from the elements, contamination, vandalism, and sunlight heat. The sun's heat can melt plastic parts.

FIGURE 4

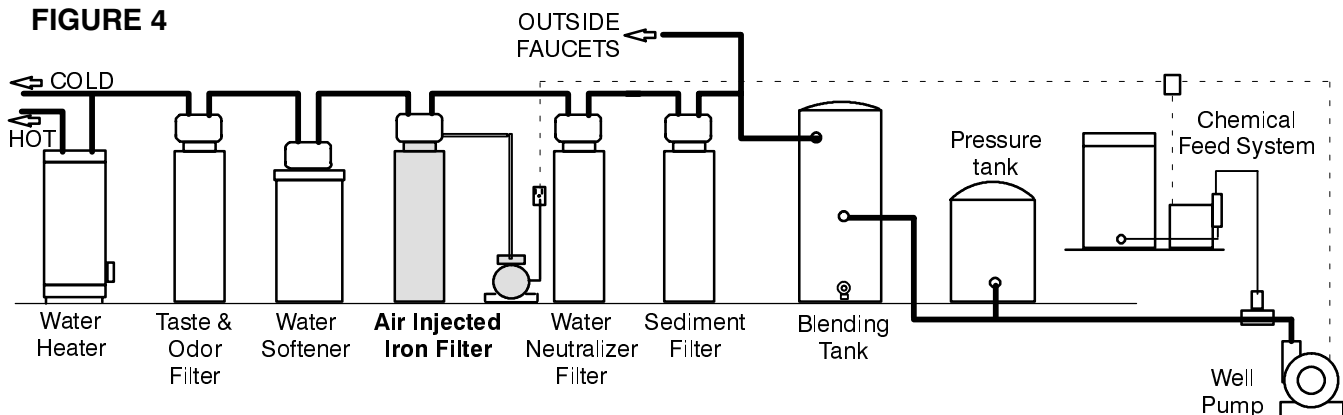

1. INSTALL INLET AND OUTLET FITTINGS

Note: All fittings are in the small parts bag.

a. Insert the turbine support, into the valve outlet port, up to the shoulder.

NOTE: If installing the EcoWater bypass valve, see separate instructions included with it.

b. Slide a lubricated o-ring onto one of the copper tubes. Carefully insert the copper tube into the outlet port (Figure 5) and secure in place with a plastic “C” clip.

Note: For lubrication, use silicone grease approved for use on potable water supplies.

c. Repeat step b on the inlet side.

2. TURN OFF WATER SUPPLY

a. Close the main water supply valve, near well pump or water meter.

b. Shut off the electricity or fuel supply to the water heater.

c. Open high and low faucets to drain all water from hose pipes.

3. INSTALLING 3-VALVE BYPASS

If installing a 3-valve bypass system, plumb as needed. If installing sweat copper, be sure to USE LEAD-FREE SOLDER as required by Federal and State codes. Use pipe joint compound on outside pipe threads.

4. MOVE FILTER INTO PLACE

Move the filter into the installation position, setting on a solid, smooth and level surface. If needed, place the filter on a section of 3/4” plywood. Then shim under the plywood to level the filter, FIGURE 6.

CAUTION: DO NOT PLACE SHIMS DIRECTLY UNDER THE SHROUD. The weight of the tank may cause the shroud to fracture at the shim.

5. ASSEMBLE INLET AND OUTLET PLUMBING

Measure, cut and loosely assemble pipe and fittings from the main water pipe (or from bypass valves installed in step 3), to the filter inlet and outlet copper tubes.

BE SURE UNFILTERED WATER SUPPLY PIPE GOES TO THE FILTER INLET SIDE. Trace the water flow direction to be sure.

FIGURE 5

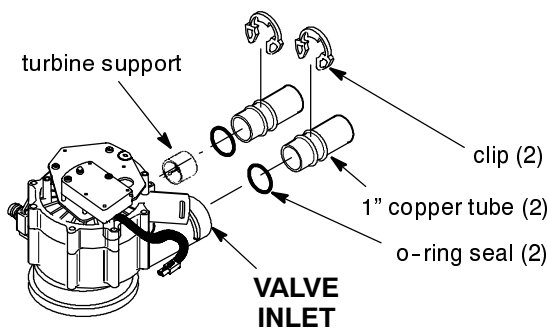
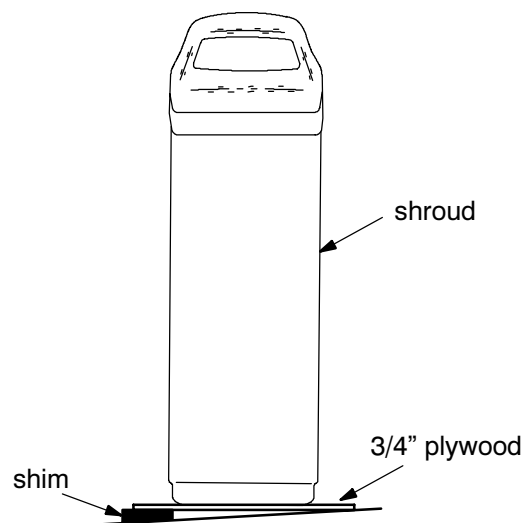

FIGURE 6



6. COLD WATER PIPE GROUNDING

The house cold water pipe (metal only) is often used as a ground for the house electrical system. The 3-valve bypass type, if installed, will maintain ground continuity. If you use the plastic bypass valve at the filter, continuity is broken. To restore the ground, install one of the following grounds.

a. Use the included hose clamps and wire to jumper across the inlet and outlet copper tubes FIGURE 7a. **NOTE:** Hose clamps must be placed on pipes before soldering.

b. Install a #4 copper wire across the removed section of main water pipe, securely clamping on both ends (figure 7b).

7. CONNECT INLET AND OUTLET PLUMBING

Complete the inlet and outlet plumbing as applicable.

a. SOLDERED COPPER

- (1) Thoroughly clean and flux all joints.
- (2) Remove the inlet and outlet tubes from the valve (pull plastic "C" clips), and o-rings from the tubes. **DO NOT SOLDER WITH TUBES IN THE VALVE. SOLDERING HEAT WILL DAMAGE THE VALVE.**
- (3) Make all solder connections. Be sure to keep fittings fully together, and pipes square and straight. **NOTE:** If using ground (step 6a), hose clamps must be placed on pipes before soldering.
- (4) **AFTER PLUMBING HAS COOLED,** repeat steps 1b and 1c.

b. THREADED PIPE

- (1) Apply pipe joint compound to all outside pipe threads.
- (2) Tighten all threaded joints.
- (3) If **SOLDERING TO INLET AND OUTLET TUBES**, observe steps (1) through (4) above.

c. CPVC PLASTIC PIPE

- (1) Clean, prime and cement all joints (follow instructions of the plastic pipe and fittings manufacturer).
- (2) **IF SOLDERING TO INLET AND OUTLET TUBES**, observe preceding steps (1) through (4).

8. INSTALL VALVE DRAIN HOSE

a. Connect a length of 5/8" I.D. (minimum) hose to the valve drain elbow on the controller FIGURE 3. The elbow accepts either a hose onto the barb fitting, or standard garden hose onto the threads. To use the threads, cut off the barbs with a hacksaw. **NOTE:** Flexible drain hose is not allowed in all localities. See option on page 8.

b. Run the hose to a floor drain, and as typically shown in FIGURE 2, tie or wire the end to a brick or other heavy object. This will prevent "whipping" during regenerations. Be sure to provide a 1-1/2" minimum air gap, to prevent possible sewer water back-up.

NOTE: In addition to a floor drain, you can use a laundry tub or stand pipe as a good drain point for this hose. Avoid long drain hose runs, or elevating the hose.

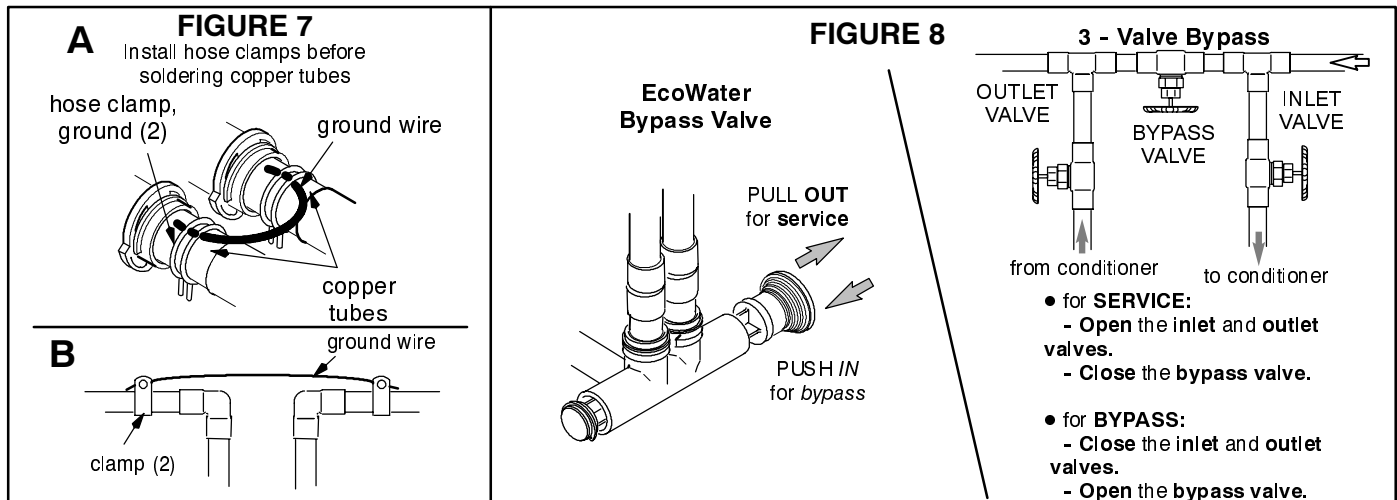

9. PRESSURE TESTING FOR LEAKS

TO PREVENT EXCESSIVE AIR PRESSURE IN THE FILTER AND PLUMBING SYSTEM, DO THE FOLLOWING STEPS IN ORDER

- a. Open two or more filtered water faucets, both hot and cold.
- b. Referring to figure 8, turn the bypass valves to service position.
- c. Slowly open the main water supply valve.
- d. Close the filtered water faucets after both of the following occur.
 - water runs smoothly, with no air bubbles
 - you can smell the sanitizing (page 5) bleach odor at the faucets
- e. Check your complete installation for leaks. If re-work is required, be sure to observe precautions in step 6.

10. CONNECT ALL LEADWIRES

a. Connect the wire harness to the valve switch FIGURE 10 and to the timer. The switch is on the outlet side valve cover, under the motor plate.

NOTE: Check to be sure the connector is secure, on the back of the timer.

- b. Attach the connector, on the valve motor leadwire, to the the matching connector on the faceplate timer.
- c. Connect the power cable leads to the two terminals on the transformer and to the the matching male connectors on the faceplate timer.

11. CONNECT AIR PUMP

- a. On the floor or a shelf nearby the filter, fasten the air pump in place.
- b. Install the air filter (if required) and tubing connector fitting.
- c. Connect the tubing from the check valve, on the adaptor, to the connector fitting on the air pump.
- d. Wire the air pump to the well pump to cycle off and on with it. This should be done by a **qualified, competent electrician**. Refer to Figure 9.

12. CONNECT TO ELECTRICAL POWER

Plug the transformer into a continuously “live”, grounded, 120V-60Hz house electrical outlet, approved by local codes.

13. TO COMPLETE INSTALLATION, DO THE PROGRAMMING STEPS ON PAGES 12 AND 13.

NOTE WATER HEATER START-UP ON PAGE 13.

FIGURE 9

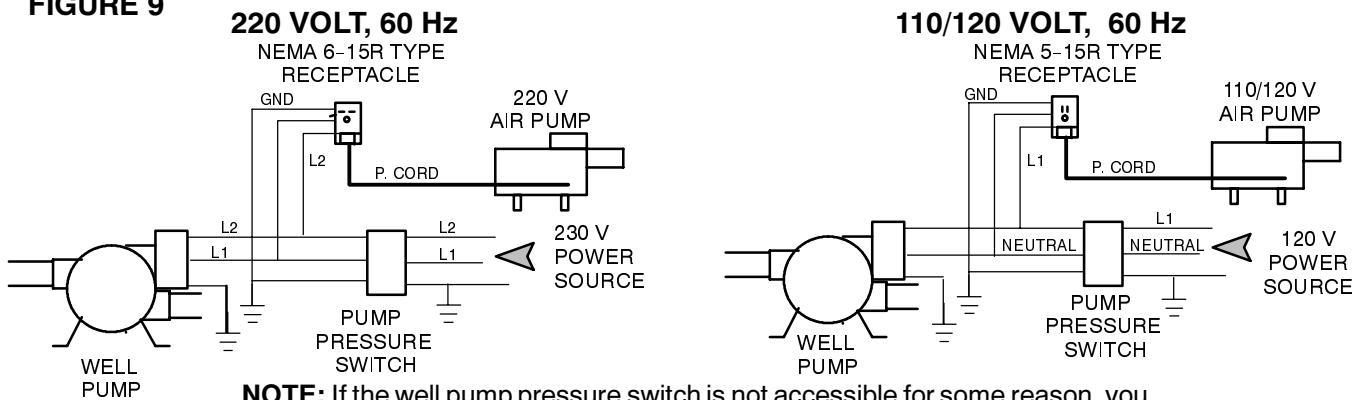

NOTE: If the well pump pressure switch is not accessible for some reason, you must install and wire to a compatible flow switch, on the **inlet** side of the filter.

FIGURE 10

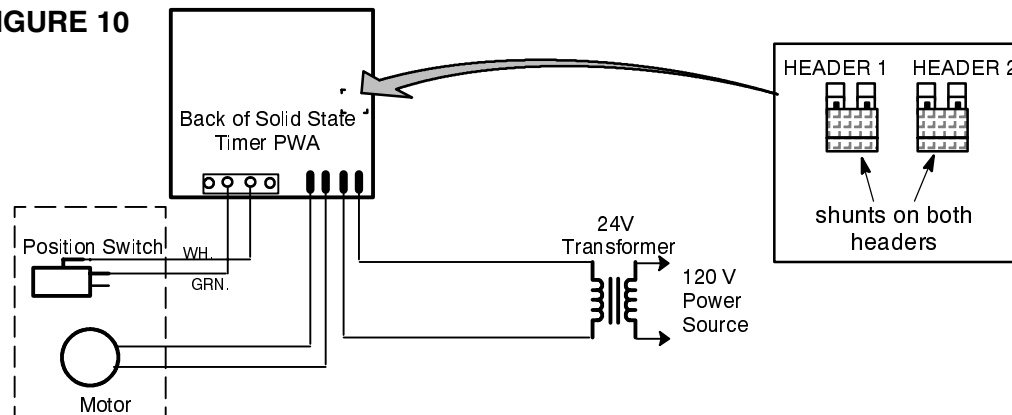

WARNING: FILTER TANK CONTAINS AIR. TO RELIEVE PRESSURE, PUT BYPASS VALVE IN BYPASS AND ADVANCE FILTER VALVE TO BACKWASH BEFORE DISASSEMBLY.

FIGURE 11

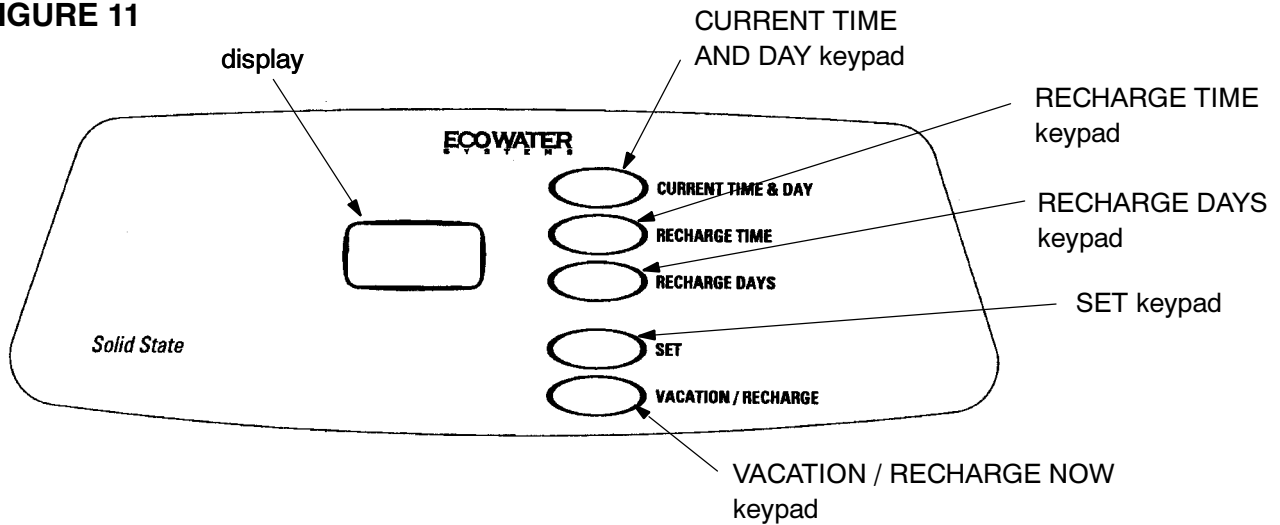

1. When the transformer is plugged into the electrical outlet, 12:00 AM, SUNDAY begins to flash in the time display. Set the **time of day** and present **day of week** as follows:

A. Set Time of Day

1. Press the CURRENT TIME AND DAY keypad once. The hour display continues to flash.
 2. Press the SET keypad until the present hour of the day shows in the display. Be sure AM for morning hours, or PM for afternoon and evening hours shows.
- Note:** Press SET and quickly release to move the hour display ahead one hour at a time to the correct hour. Or, **hold** the SET keypad to move the display ahead two hours each second, to the correct hour.
3. Press CURRENT TIME AND DAY keypad once to steady the hour display, and minutes begin to flash. Press SET until the correct minutes show in the display.
 4. Press CURRENT TIME AND DAY keypad again to steady the minute display (day will begin flashing).

B. Set Present Day of Week

1. Press the SET keypad to set the present day of the week in the display.
- Note:** Press SET and quickly release to move the day display one day at a time, **hold** the SET keypad to move the display ahead two days each second.

2. Press the CURRENT TIME AND DAY keypad again to steady the entire display.

C. Set Days and Time of Backwash

Note: The timer is factory set (default time) for Monday, Wednesday, and Saturday backwashes, beginning at 12:00 AM. If you have an Eco Water conditioner or another filter installed, the backwash timer and/or days should be offset to assure adequate water flow and pressure. For example, set the filter to start backwash at 12:00 AM, or 4:00 AM, if the conditioner is set to begin recharge at 2:00 AM.

1. Press RECHARGE TIME keypad once, to display the factory set backwash days and starting time (flashing). To change the backwash start time, do step 2 following, otherwise proceed to step 3.
 2. Press the SET keypad until the desired backwash starting time shows in the display.
- Note:** Press SET and quickly release to move the display ahead one hour at a time, **hold** the SET keypad to move the display ahead two hours each second.
3. Press the RECHARGE DAYS keypad and SUNDAY begins to flash.

...If you **want** backwashes on Sunday, press the SET keypad to display **ON**.

NOTE: One backwash each week is usually sufficient to keep the mineral bed clean and expanded. If the water supply contains iron, or high sediments, additional backwashes may be needed.

...If you **do not want** Sunday backwashes, press SET keypad to display **OFF**.

4. Press the RECHARGE DAYS keypad again to display a flashing MONday and **ON** (factory set recharge). As you did in step 3, use the SET keypad to change the display from ON to OFF, or from OFF to ON, as desired.

5. Press RECHARGE DAYS keypad to display a flashing TUEsday, WEDnesday, etc., each time using the SET keypad to display either ON or OFF as needed.

2. Press and hold the VAC/RCHG keypad for three seconds until RCHG begins to flash in the display, starting a backwash. This backwash flushes “fines” from the new mineral, and purges air and bleach, re-

maining from the sanitizing procedure. The filter returns to service in about 45 minutes.

3. RESTART THE WATER HEATER: Turn on the electric or fuel supply to the water heater, and light the pilot, if applies. **Note:** The water heater is filled with unfiltered water and, as hot water is used, it re-fills with filtered water. In a few days, hot water will be fully filtered. To have fully filtered water immediately, wait until the recharge (step 2 above) is over. Then, drain the water heater until water runs cold.

THE SOLID STATE TIMER IS NOW PROGRAMMED AND INSTALLATION IS COMPLETE.

FEATURES / OPTIONS

RECHARGE NOW – For an immediate extra backwash at any time. Press and **hold** in the VAC/RCHG keypad for three seconds until **RCHG** flashes in the display. The filter backwashes for 25 minutes, followed by a 5 minute fast rinse cycle. Then the filter returns to service.

VACATION – The day you leave on vacation, or other long absence, press (DO NOT HOLD IN) the VAC/RCHG keypad. **VAC** begins to flash in the display. The timer will keep time, but the filter will not backwash and waste water.

Note: While in the VACATION setting, the filter **will** go through a backwash if the RECHARGE NOW feature is used (see above).

WHEN YOU RETURN, press the VAC/RCHG keypad again to return the filter to service, and the correct time of day in the display. **Remember to to this or the filter will not backwash and you will soon have unfiltered water.**

DOUBLE BACKWASH – Although available on this timer, a double backwash cycle is not normally needed with a sediment, taste and odor, or neutralizing filters. To set, if desired...

1. Press and **hold** SET until 18:88 shows in the display..



2. Press CURRENT TIME AND DAY to display 3 dashes.



3. Press SET to display **dbl**.

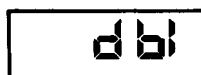

4. Press CURRENT TIME AND DAY to display 18:88.

5. Press SET to return present time.

To **cancel** double backwash, repeat the above steps. Displays for **dbl** and **---** occur in reverse order.

TIMER “POWER-OUTAGE MEMORY” – If electrical power to the timer goes off, the “memory” built into the timer circuitry keeps **all** settings for at least two days or more. The display is blank and the filter will not backwash. When electrical power comes on, one of two things will happen.

1. The present time of day will show, meaning the timer memory has kept all settings.

Note: *If the filter was **in** a backwash when power was lost, it will now finish the cycle.*

2. The display will show a time, but it will be flashing. The timer memory did **not** keep the time settings and they must be reset.

The flashing display is to remind you to reset the timer.

Notes:

When power comes on, the flashing display returns to a time of 12:00 AM SUnDay, then begins to keep time again. If you do not reset all time settings, the filter will backwash three days each week (default time). However, backwash may be on the wrong days and at the wrong time.

If the filter was in a backwash when power went off, the valve will return to service position without finishing the cycle. If your water is unfiltered, use the RECHARGE NOW feature to start another cycle.

INFORMATION FOR QUALIFIED TECHNICIANS ONLY

RECHARGE CYCLE TIME ADJUSTMENTS: Factory set default cycle times are:

BACKWASH...25 minutes, and **FAST RINSE**...5 minutes. Do the following to check for correct cycle times.

Note: Removing from electrical power (about two days) resets times to factory set defaults.

DISPLAY MUST SHOW TIME AND DAY

1. Press and **hold** SET ... entire display comes on.



2. Press RECHARGE TIME ... 2:00 should show in the display. If not, press SET until 2:00 does show.



3. Press RECHARGE TIME ... 3:25 shows, meaning #3 cycle (backwash) and 25 minutes.



a. If 3:25 **does** show, go to step 4.

*b. If other than 3:25 (3:00 to 3:30), press SET until 3:25 shows.



4. Press RECHARGE TIME ... 4:05 shows, meaning #4 cycle (fast rinse) and 5 minutes.



a. If 4:05 **does** show, go to step 5.



b. If other than 4:05 (4:00 to 4:30), press SET until 4:05 shows.



5. Press RECHARGE TIME ... 18:88 shows.

6. Press SET to return present time and day.

*Or, set other cycle length, if desired.

GENERAL INFORMATION

The air injector adaptor installs between the filter valve and mineral tank as shown below in figure 2. A pump injects air into the iron filter through the

adaptor. The air oxidizes iron and it is mechanically filtered by the filter mineral bed. The injector adaptor float allows excess air to vent from the tank.

SERVICE, BACKWASH AND FAST RINSE

SERVICE (See Figure 12): Unfiltered water enters the valve inlet port. Internal valve porting routes the water down and out the top distributor, into the mineral tank. The water is filtered as it passes through the mineral bed, then enters the bottom distributor. Filtered water flows back into the valve and out the valve outlet, to the house filtered water pipes.

In time, the filter needs cleaning to remove sediments, dirt, iron, etc., from the mineral bed. This cleaning is done in two stages, or cycles, called backwash and fast rinse. It is started automatically by the timer.

BACKWASH (See Figure 13): The timer starts the valve motor and moves the valve into backwash

position. Water is routed down and out the bottom distributor, up through the mineral bed, and out the top distributor to the drain. The fast flow (controlled by a flow plug in the drain fitting) flushes dirt, sediments, iron deposits, etc. to the drain. The mineral bed is lifted and expanded for maximum cleaning.

FAST RINSE (See Figure 14): Valve rotation positions the inner discs so water flow enters the mineral tank through the top, and exits at the bottom, to the drain. The fast flow of water downward, packs the mineral bed and prepares it for return to service.

The timer energizes the valve motor again to return the valve to service.

WATER FLOW PATHS

FIGURE 12
SERVICE CYCLE

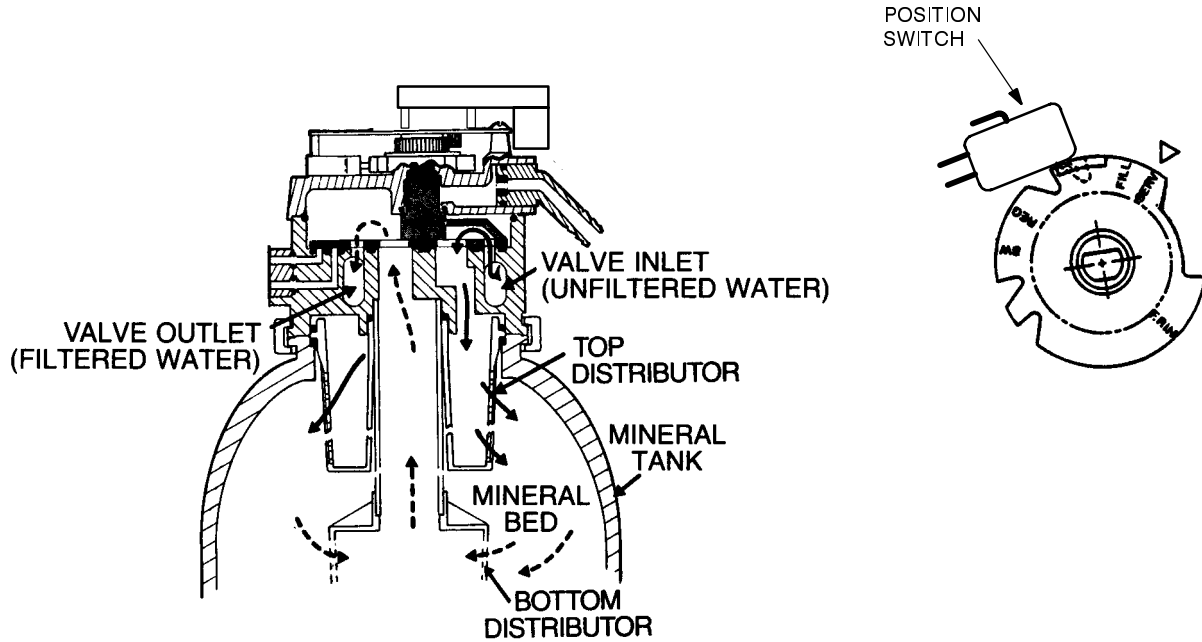

FIGURE 13
BACKWASH CYCLE

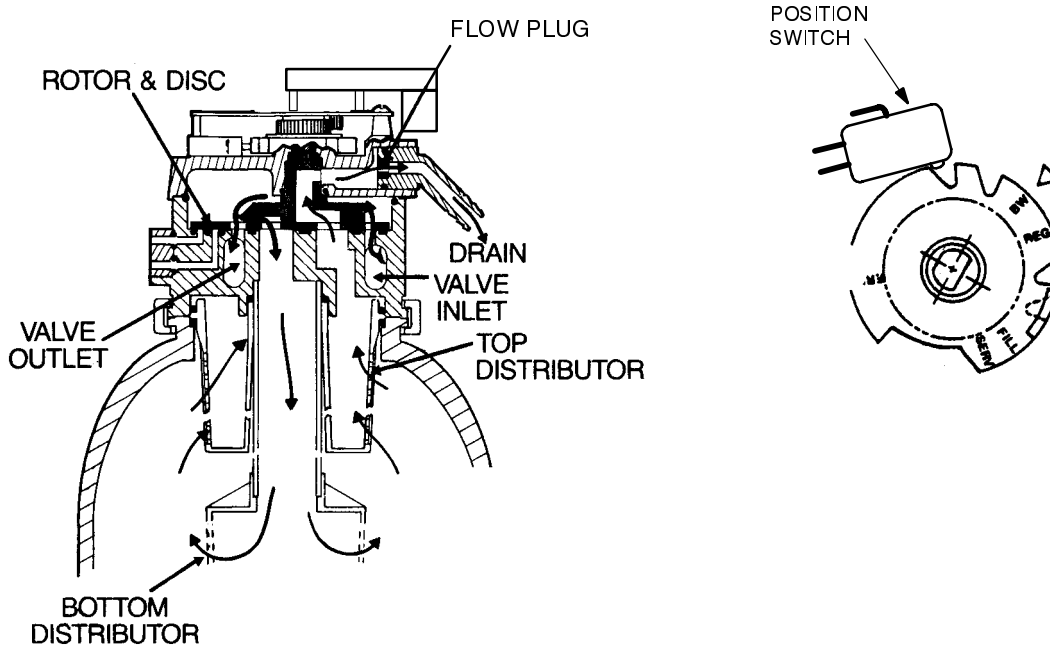
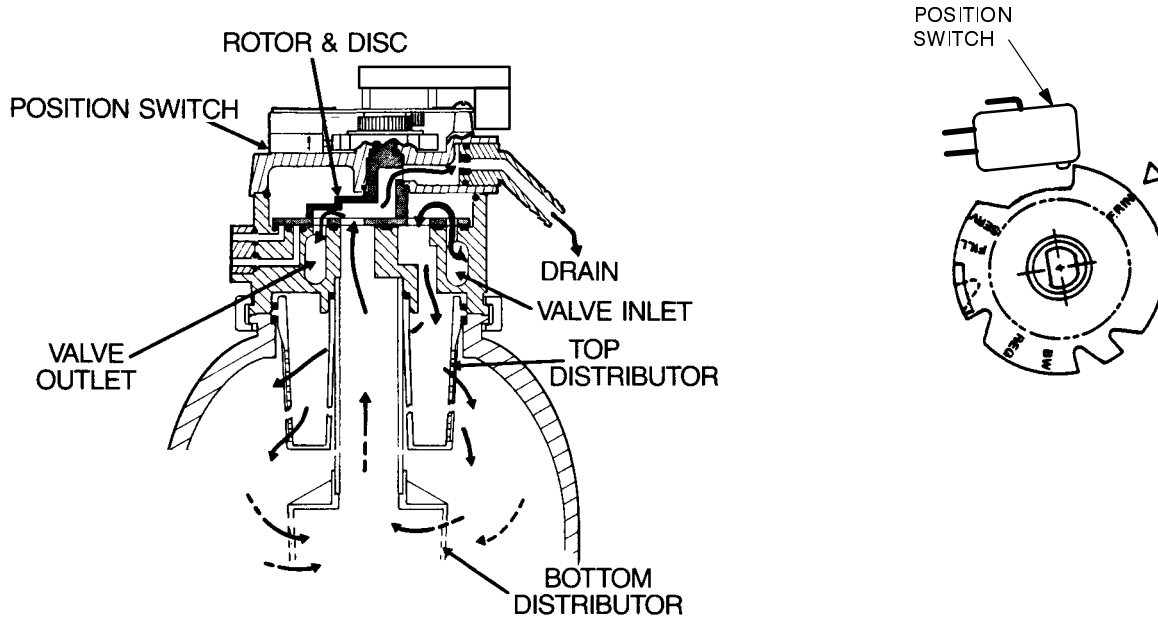

FIGURE 14
FAST RINSE CYCLE



Adaptor Troubleshooting Guide

If excess air is in household plumbing, the air vent is most likely plugged with debris.

Temporarily move the pump tube to the drain fitting and energize the air pump.

After vent is cleared, change tubing back.

WARNING: FILTER TANK CONTAINS AIR. TO RELIEVE PRESSURE, PUT BYPASS VALVE IN BYPASS AND ADVANCE FILTER VALVE TO BACKWASH BEFORE DISASSEMBLY.

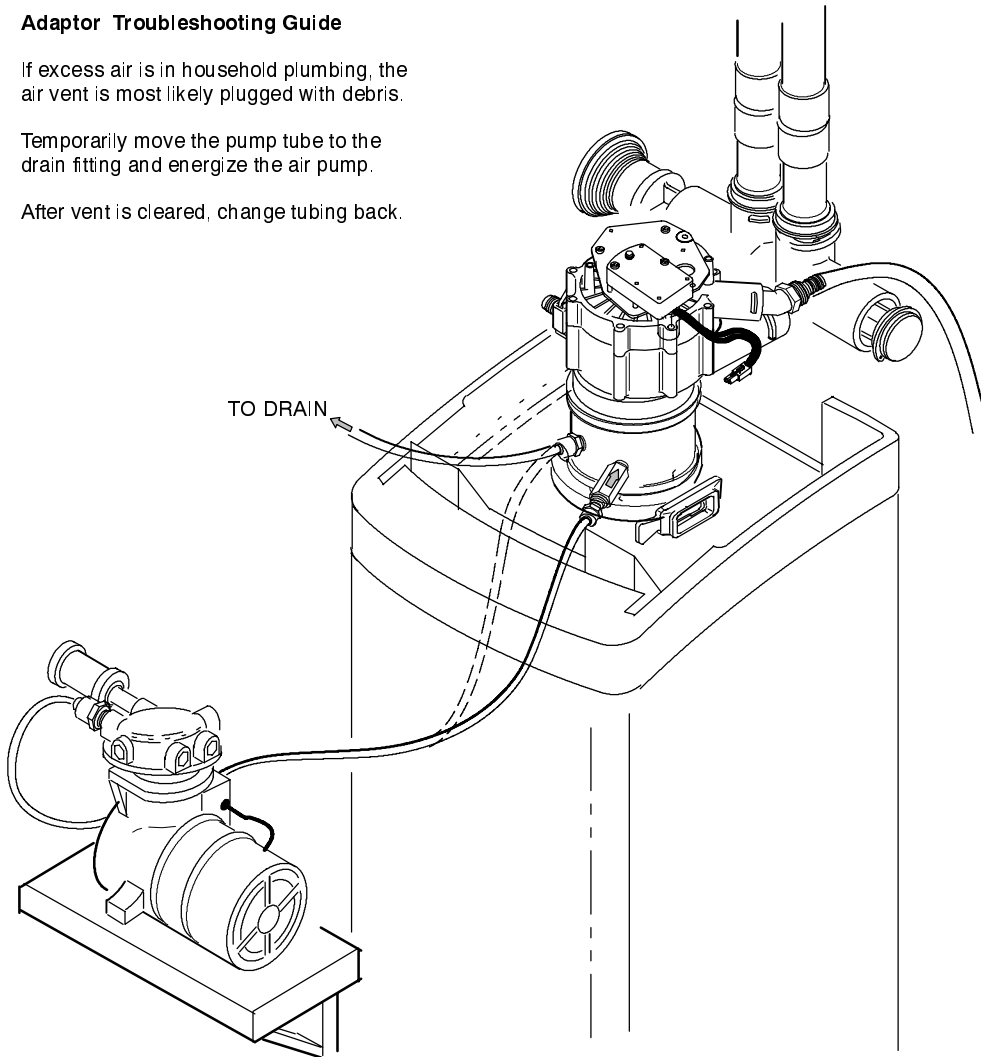

TROUBLESHOOTING

ALWAYS MAKE THESE INITIAL CHECKS FIRST

1. Does the time display show the correct time of day?

...If display is blank, check power source to the filter.

...If time is flashing, power was off for over two days. The filter resumes normal operation but backwashes occur at the wrong time.

2. Plumbing bypass valve(s) must be in SERVICE position (see figure 7, page 9).

3. The inlet and outlet pipes must connect to the filter inlet and outlet respectively.

4. Is the transformer plugged into a “live” grounded wall outlet, and the power cable fastened securely?

5. The valve drain hose must be free of kinks and sharp bends.

If you do not find the problem after making the initial checks, do the **MANUAL ADVANCE DIAGNOSTICS**.

MANUAL ADVANCE DIAGNOSTIC

Use the following procedures to advance the filter valve through the regeneration cycles to check operation.

Remove the top cover to observe cam and switch operation during valve rotation.

DISPLAY MUST SHOW TIME AND DAY

1. Press and hold set for 3 seconds until 18:88 displays.

2. Press RECHARGE DAY to display the position switch open or closed indicator.



The letter (P) and dash or dashes indicate position switch operation. The letter shows if the switch is closed. A dash shows when the switch is open.

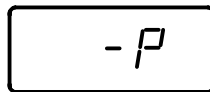

NOTE: *The position switch is closed when the plunger is depressed, open when extended.*

CORRECT SWITCH DISPLAYS	VALVE CYCLE STATUS
- -	valve in service, backwash or fast rinse position
- P	valve rotating from one position to another

NOTES:

While in manual advance, the time display will automatically return to the present time, if a face plate keypad is not pressed within four minutes.

Pressing VAC/RCHG while the motor is running has no effect.

3. To enter backwash, press and **hold** VAC/RCHG for three seconds to start the motor.

a. If the motor does not run, check the motor and all wiring connections.

Look for a fast flow of water from the drain hose (see specs).

a. An obstructed flow indicates a plugged top distributor, backwash flow plug, or drain hose.*

*Note: Be sure household water pressure (well system) is maintained at a minimum of 20 psi. Adjust the pump switch upward, if needed.

4. Press VAC/RCHG to move the filter into fast rinse. Again, look for a drain flow rate about the same and in backwash.

5. To return the filter to service, press VAC/RCHG once.

6. Upon returning to service, press RECHARGE DAY to display 18:88.

7. Press SET to return to the present time.

OTHER SERVICE

UNFILTERED WATER BYPASS (unfiltered water "bleeds" into filtered water supply.

1. Defective inlet disc, seal or wave washer (see

pages 22 and 23).

2. Missing or defective o-ring(s) at resin tank to valve connection (see pages 20 & 21).

AUTOMATIC ELECTRONIC DIAGNOSTICS

The face plate has a self diagnostic function for the electrical systems (except input power). The face-

plate monitors the electronic components and circuits for correct operation. If a malfunction occurs, an error code appears in the faceplate display.

POSSIBLE DEFECT

CODE	MOST LIKELY	LEAST LIKELY
Err 01 Err 02 Err 03 Err 04	wiring harness or connection to position switch / switch / valve defect causing high torque / motor inoperative	
Err 05	faceplate	

PROCEDURE FOR REMOVING ERROR CODE FROM FACEPLATE: 1. Unplug transformer---- 2. Correct defect---- 3. Plug in transformer---- 4. Wait for 6 minutes. The error code will return if the defect was not corrected. Press and hold the VAC/RCHG keypad for 3 seconds as an alternate way to clear an error code.

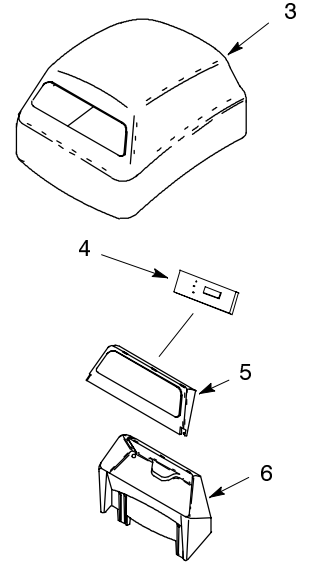
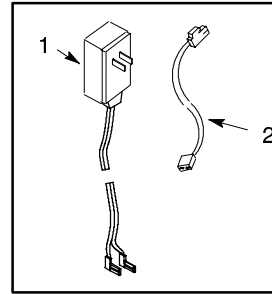
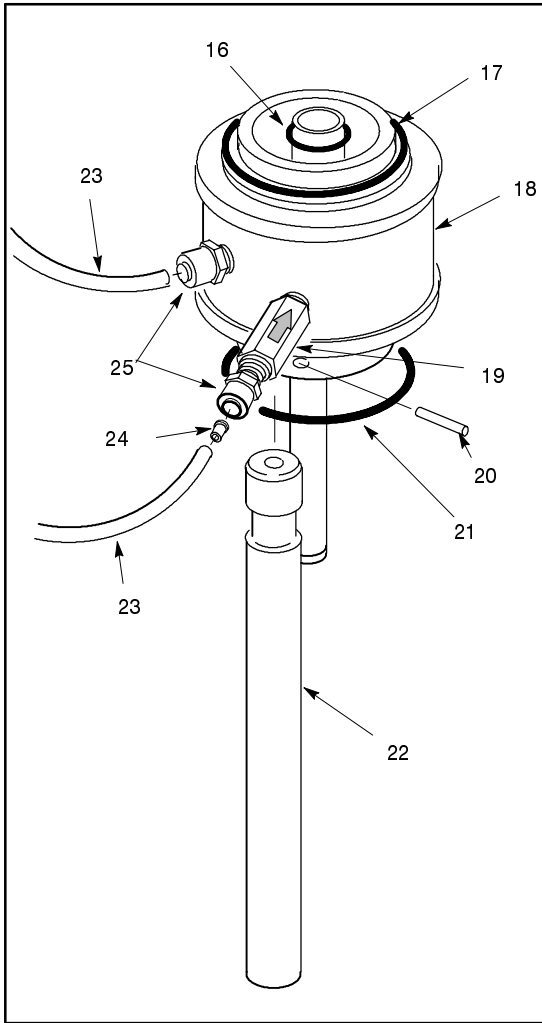

Valve Assembly
(see page 22)

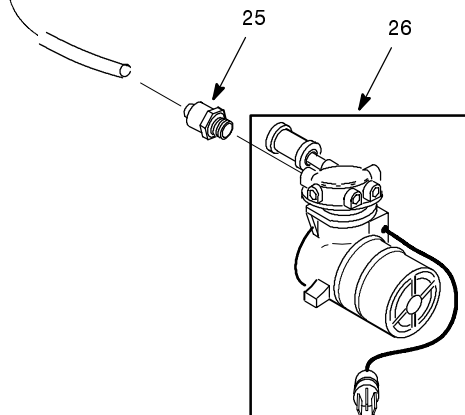
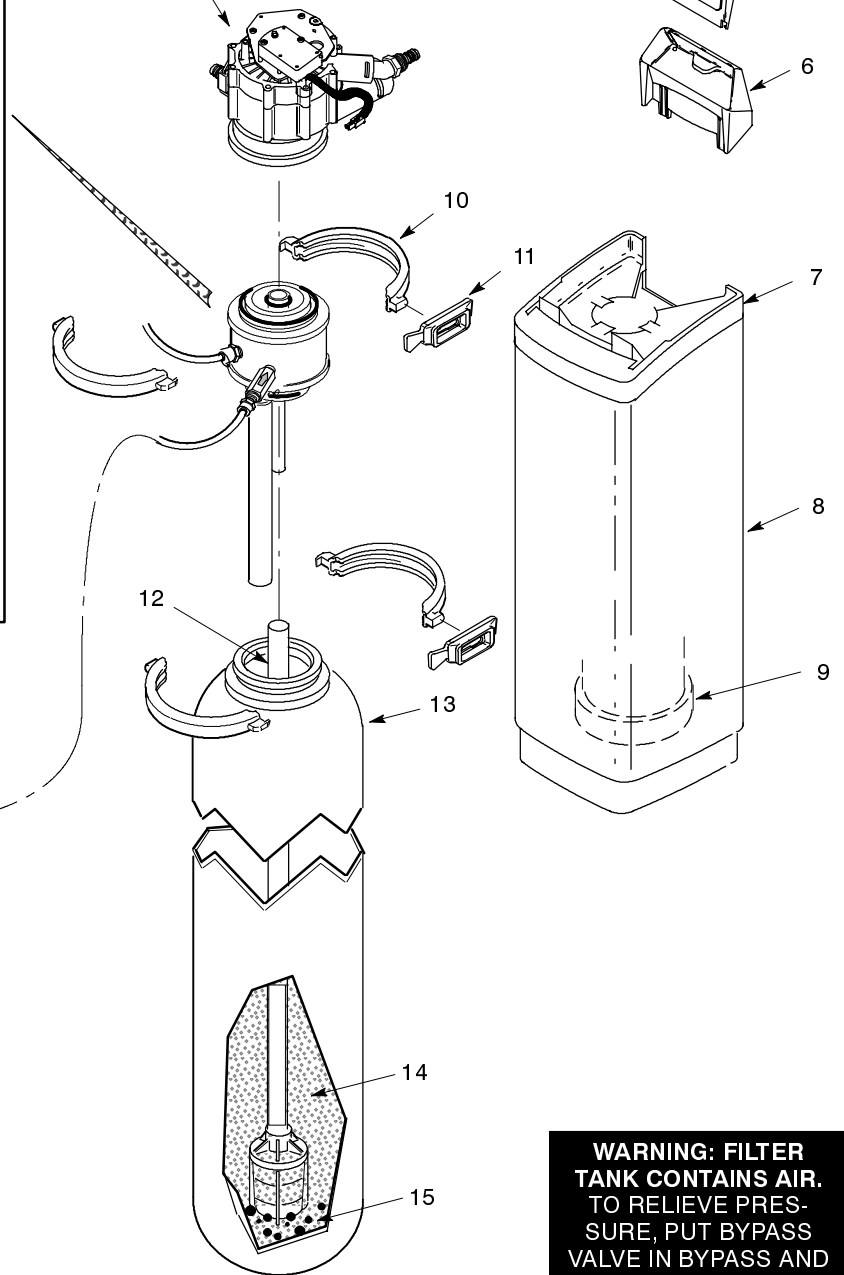

WARNING: FILTER TANK CONTAINS AIR. TO RELIEVE PRESSURE, PUT BYPASS VALVE IN BYPASS AND ADVANCE FILTER VALVE TO BACKWASH BEFORE DISASSEMBLY.

KEY NO.	PART NO.	PART DESCRIPTION
1	7252373	Transformer, 24V - 10VA
2	7130767	Wire Harness
3	7218670	Top Cover
4	7218701	Rep'l PWA
5	7210517	Faceplate (order following decal)
-	7214197	Decal
6	7211173	Faceplate Support
7	7220431	Rim
8	7223308	Shroud
9	7141205	Tank Base
10	7088033	Clamp Retainer (Clip), 4 req'd
11	7176292	Clamp Section, 4 req'd
12	7223316	Rep'l Distributor, bottom
13	7223324	Resin Tank, 9" dia. x 60"
14	0509957	Birm Pkd
15	7124415	Quartz
16	7170254	O-ring, 13/16 I.D. x 1-1/16 O.D.
17	7170296	O-ring, 2-7/8 I.D. x 3-1/4 O.D.
18	7251880	Adaptor Asm (includes Key Nos. 20 & 26 qty of 2) ■
19	7190628	Check Valve ■
20	7190602	Pin ■
21	7170270	O-ring, 2-3/4 I.D. x 3 O.D.
22	7220407	Float Asm ■
23	7161784	Tubing, 1/4" x 100 ft.
24	7199486	Insert, Restrictor ■
25	7171666	Connector, 3 req'd ■
26	7219901	Air Pump, 115 V
-	7219919	Air Pump, 220 V
■	7223332	Adaptor Kit

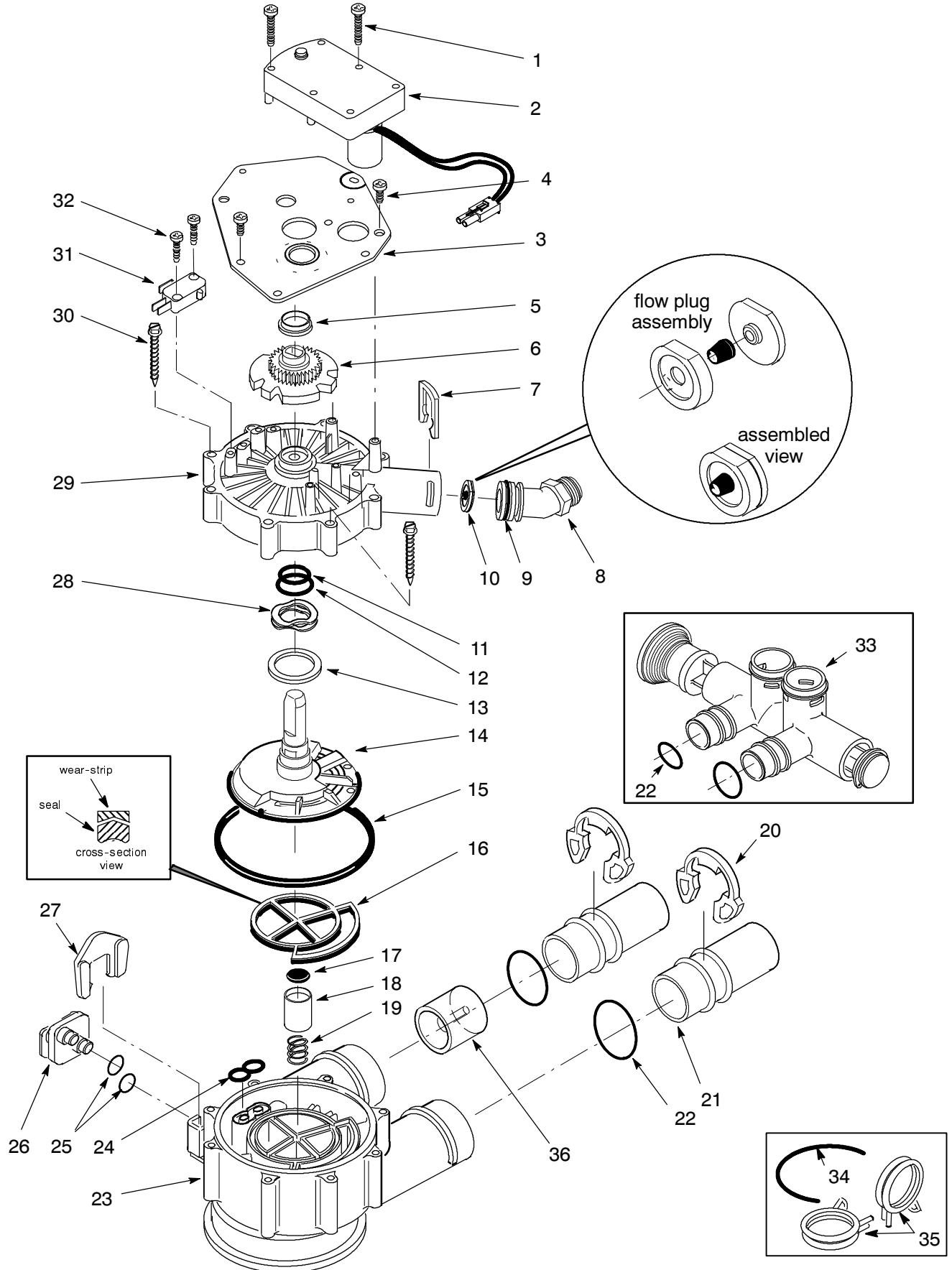

KEY NO.	PART NUMBER	DESCRIPTION OF PART
1	7224087	Screw, #8-32 x 1" (2 req.)
2	7234731	Motor (incl. 2 ea. of Key No. 1)
3	7231393	Motor Plate
4	0900857	Screw, #6-20 x 3/8 (3 req.)
5	7171250	Bearing
6	7219545	Cam and Gear
7	7169180	Clip (Drain)
8	7172793	Drain Hose Adaptor
9	7170288	O-ring, 15/16 x 1-3/16
10	7178189	Flow Plug, 5 gpm
11	7170327	O-ring, 5/8 x 13/16 ■
12	7173024	O-ring, 1-1/8 x 1-1/2 ■
13	7174313	Bearing, Wave Washer
14	7185500	Rotor & Disc
15	7173032	O-ring, 4-1/2 x 4-7/8 ■
16	7171179	Rotor Seal ■
-	7171331	Wear Strip ■
17	7172989	Seal ■
18	7171187	Plug (Drain Seal)
19	7129889	Spring
20	7089306	Clip (2 req.)
21	7077642	Copper Tube, 1" (2 req.)
22	7170262	O-ring, 1-1/8 x 1-3/8 (4 req.)

KEY NO.	PART NUMBER	DESCRIPTION OF PART
23	7171145	Valve Body
24	7195482	Seal ■
25	7170319	O-ring, 1/4 x 3/8
26	7100940	Plug
27	7081201	Retainer
28	7175199	Wave Washer
29	7171161	Valve Cover
30	7172997	Screw, #10 x 2-5/8 (8 req.)
31	7145186	Switch
32	7140738	Screw, #4-24 x 3/4 (2 req.)
33	7214383	Bypass Valve (Includes following parts) ①
-	7172882	Stem
-	7173016	O-ring, 1.109 I.D. x 1.387 O.D. (4)
-	7175238	C-ring
34	7207726	Ground Wire
35	7163427	Hose Clamp (2)
36	7078240	Support
■	7185487	Seal Kit (incl. Key Nos. 11, 12, 15, 16, 17 and 24)

① Optional part.

ECOWATER
S Y S T E M S[®]

