



EcoWater **SERIES ESS1000X** Water System

ECOWATER CUSTOMER . . . Your EcoWater dealer has assembled, installed, and adjusted the water system to your household's specific needs. Just keep the brine tank filled with salt and the EcoWater System unit will provide you with a continuous supply of conditioned water. *Check the salt storage level every few weeks*, and always refill the tank before all the salt is gone. Use cube, pellet, or other **clean** water softener salt. **Do not** use rock salts, or salt with iron removing additives. Iron removing additives release fumes that may corrode and shorten the life of some EcoWater System unit parts.

Your dealer has set the solid-state timer to the correct times, and

for the needed regeneration schedule to provide you with continuous soft water. If electrical power to your house . . . or just to the EcoWater System unit . . . is interrupted, use the procedures on pages 5 and 6 to reset the timer.

Note: The timer has a 48 hour (or more) "POWER-OUTAGE MEMORY". When electrical power goes off, but is then restored within the 48 hours, the correct time shows and all other settings are maintained. When power is off longer, a time will *flash* in the display meaning you must make all timer settings.

LIMITED WARRANTY

EcoWater Systems, Inc. ADVANTAGE WARRANTY Series ESS1000X Water System

Congratulations! You have just purchased the highest quality water conditioning product on the market. To register your warranty, complete the enclosed Warranty Registration Card and mail it within 30 days of purchase.

To whom is this warranty extended?

EcoWater Systems, Inc. warrants its products to the original owner and guarantees that the products will be free from defects in materials and workmanship from the original date of installation.

How does this warranty work?

If, during the respective warranty period, a part proves, after inspection by EcoWater, to be defective, EcoWater will, at its sole option repair or replace that part at no charge, other than normal shipping, installation or service charges.

What is covered by the warranty?

EcoWater Systems, Inc. guarantees that,

for a period of TEN (10) years, the SALT TANK and the MINERAL TANK will not rust, corrode, leak, burst, or in any other manner fail to perform their proper functions and that,

for a period of ONE (1) year after installation, the VALVE BODY and ALL OTHER PARTS will be free of defects in materials and workmanship and will perform their proper functions.

How do I obtain warranty service?

Should you need service, your local, independent EcoWater Dealer is only a phone call away. PHONE: _____
To obtain warranty service, notice must be given, within thirty (30) days of the discovery of the defect, to your local EcoWater Systems dealer.

If I need a part replaced after the factory warranty expires, is the replacement part warranted?

Yes, EcoWater Systems, Inc. warrants FACTORY REPAIRS as well as all REPLACEMENT PARTS for a period of 90 DAYS. This warranty does not include normal shipping, installation or service charges.

General Provisions

The above warranties are effective **provided** the water conditioner is operated at water pressures not exceeding 125 psi, and at water temperatures not exceeding 120°F; provided further that the water conditioner is not subject to abuse, misuse, alteration, neglect, freezing, accident or negligence; and provided further that the water conditioner is not damaged as the result of any unusual force of nature such as, but not limited to, flood, hurricane, tornado or earthquake. EcoWater Systems, Inc., is excused if failure to perform its warranty obligations is the result of strikes, government regulation, materials shortages, or other circumstances beyond its control.

There are no warranties on the water conditioner beyond those specifically described above. All implied warranties, including any implied warranty of merchantability or of fitness for a particular purpose, are disclaimed to the extent they might extend beyond the above periods. The sole obligation of EcoWater Systems, Inc. under these warranties is to replace or repair the component or part which proves to be defective within the specified time period, and EcoWater is not liable for consequential or incidental damages. No EcoWater dealer, agent, representative, or other person is authorized to extend or expand the warranties expressly described above.

Some states do not allow limitations on how long an implied warranty lasts or exclusions or limitations of incidental or consequential damage, so the limitations and exclusions in this warranty may not apply to you. This warranty gives you specific legal rights, and you may have other rights which vary from state to state. This warranty applies to consumer-owned installations only.

DIMENSIONS

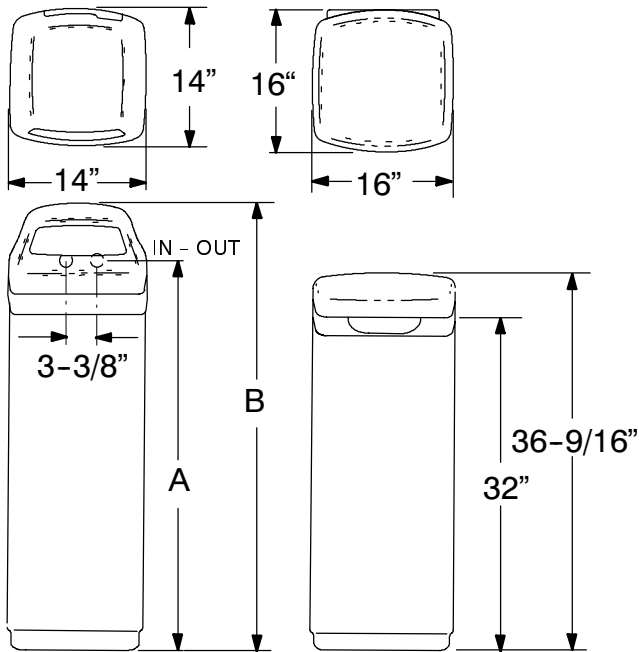

| | ESS1000XR24 | ESS1000XR32 |
|---|--|---|
| Rated Capacity | 11,900 @ 2.3 19,800 @ 4.7 26,700 @ 8.6 | 15,300 @ 3.0 25,600 @ 6.1 34,500 @ 11.1 |
| Service Flow Rate | 8.0 | 9.0 |
| Pressure Drop at Service Flow Rate | 15 | 14 |
| Amount of High Capacity Resin (cu ft) | .78 | 1.01 |
| Water Pressure Limits (min./max. psi) ♦ | 20 - 125 | |
| Min./Max. Water Temperature (°F) | 40° - 120° | |
| Min. Water Supply Flow Rate (gpm) | 3 | |
| Max. Drain Flow Rate (gpm) | 2.2 | 2.0 |

These systems, when containing EcoWater Systems resin part numbers 0502272 or 0501741, conform to NSF/ANSI 44 for the specific performance claims as verified and substantiated by test data.

♦ Maximum working pressure for Canadian use is 100 psi.

| MODEL | NOMINAL RESIN TANK SIZE | A | B |
|-------------|-------------------------|-------|--------|
| ESS1000XR24 | 8" DIA. X 40" | 41.6" | 48.75" |
| ESS1000XR32 | 10" DIA. X 47" | 49.8" | 56.6" |

ECOWATER DEALER INFORMATION

SAFETY GUIDES, INSTALLATION AND OPERATION REQUIREMENTS

FOLLOW THE INSTALLATION INSTRUCTIONS CAREFULLY. FAILURE TO INSTALL THE UNIT PROPERLY VOIDS THE WARRANTY.

CHECK LOCAL PLUMBING AND ELECTRICAL CODES. THE INSTALLATION MUST CONFORM TO THEM. IN MASSACHUSETTS, PLUMBING CODES OF MASSACHUSETTS SHALL BE ADHERED TO. CONSULT WITH YOUR LICENSED PLUMBER.

USE ONLY LEAD-FREE SOLDER AND FLUX FOR ALL SWEAT-SOLDER CONNECTIONS, AS REQUIRED BY STATE AND FEDERAL CODES.

USE CARE WHEN HANDLING THE UNIT. DO NOT TURN UPSIDE DOWN, DROP, OR SET ON SHARP PROTRUSIONS.

DO NOT LOCATE THE UNIT WHERE FREEZING TEMPERATURES OCCUR. DO NOT ATTEMPT TO TREAT WATER OVER 120°F. **FREEZING, OR HOT WATER DAMAGE VOIDS THE WARRANTY.**

AVOID INSTALLING IN DIRECT SUNLIGHT. EXCESSIVE SUN HEAT MAY CAUSE DISTORTION OR OTHER DAMAGE TO NON-METALLIC PARTS.

THE SYSTEM REQUIRES A MINIMUM WATER FLOW OF 3 GALLONS PER MINUTE AT THE INLET. **MAXIMUM ALLOWABLE INLET WATER PRESSURE IS 125 PSI.** IF DAYTIME PRESSURE IS OVER 80 PSI, NIGHTTIME PRESSURE MAY EXCEED THE MAXIMUM. USE A PRESSURE REDUCING VALVE IF NECESSARY. (ADDING A PRESSURE REDUCING VALVE MAY REDUCE THE FLOW.)

THE UNIT WORKS ON 24 VOLT-60 Hz ELECTRICAL POWER ONLY. BE SURE TO USE THE INCLUDED TRANSFORMER.

THIS SYSTEM IS NOT INTENDED TO BE USED FOR TREATING WATER THAT IS MICROBIOLOGICALLY UNSAFE OR OF UNKNOWN QUALITY WITHOUT ADEQUATE DISINFECTION BEFORE OR AFTER THE SYSTEM.

ECOWATER DEALER INFORMATION

BRINE TANK ASSEMBLY

Note: On some models, the factory may complete steps 1 and 2 below.

1. Locate the brinewell in position and secure with a screw and nut (from parts skin-pack).
2. Lower the brine valve into the brinewell and install the brinewell cover.
3. Insert the grommet into the hole in the tank sidewall. Then, push the hose adaptor elbow into the grommet.

Do the remaining assembly during installation.

FIG. 1

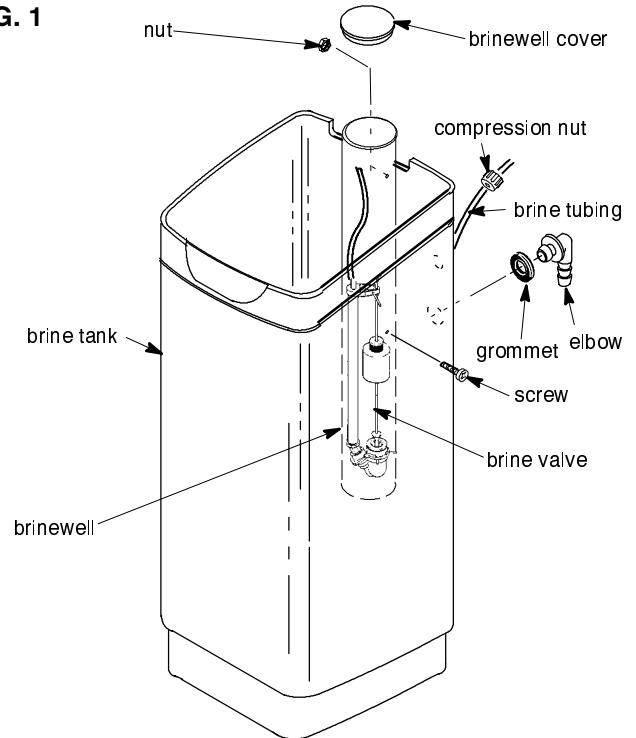

INSTALLATION

BE SURE TO READ AND COMPLY WITH ALL GUIDES LISTED ON PAGE 2.

1. Install the installation adaptors, or the optional bypass valve (fig. 2). **Be sure clips hold parts firmly in place.** Pull on the adaptors or bypass valve to insure they are secure.

Note: If the optional bypass valve is not used, be sure to install a 3-valve bypass (fig. 3). Bypass valves allow you to turn off water to the softener for repairs if needed, but still have water in the house pipes.

2. Run the **hard water** supply to the **valve inlet**, and **conditioned water** out from the **valve outlet**.

Note: Use the copper tubes, nuts and gaskets that are on the skin-pack. You can also plumb directly to the 1" NPT threads on the installation adaptors.

CAUTION: Do all soldering, and allow to cool, before connecting pipe to the adaptors or bypass valve.

3. Install the hose clamps and wire if cold water pipe ground continuity was interrupted. **Note:** hose clamps must be placed on pipes before soldering.

FIG. 3

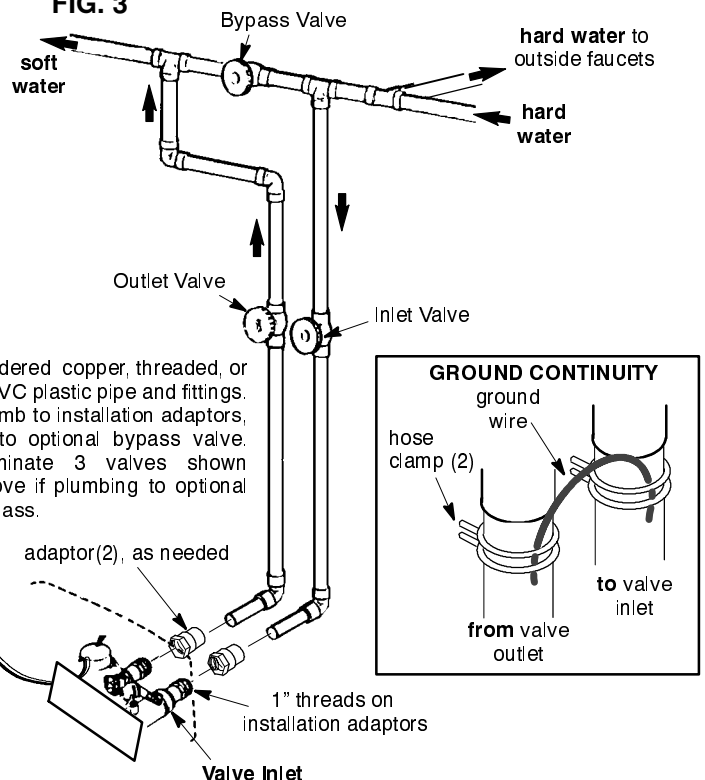
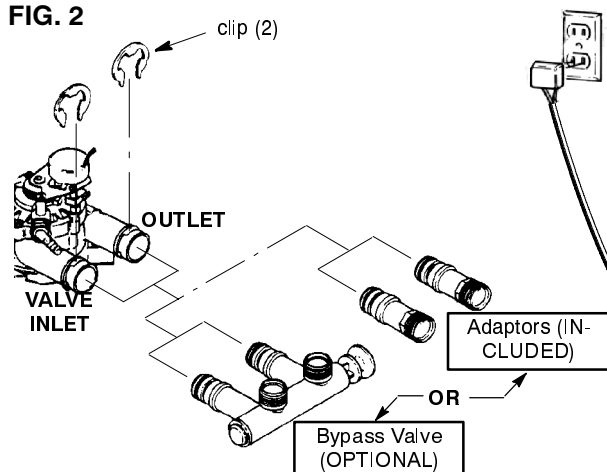

FIG. 2



Soldered copper, threaded, or CPVC plastic pipe and fittings. Plumb to installation adaptors, or to optional bypass valve. Eliminate 3 valves shown above if plumbing to optional bypass.

ECOWATER DEALER INFORMATION

INSTALLATION (continued)

- Run the valve and brine tank overflow drain hoses (fig. 4). Secure the valve drain hose to the drain fitting with the included hose clamp. Provide a minimum 1-1/2" air gap at the floor drain, standpipe, laundry tub, or other approved drain. If you need to elevate the valve drain hose to get to the drain point, do not raise more than 8' above the floor. The *gravity* overflow hose must be lower than the drain fitting along the entire run.

Note: Flexible drain hose is not allowed by some state or local codes. A fitting (1/4" NPT x 1/2" O.D. tube, part no. 0504574) is available from EcoWater for adapting copper tubing to the valve drain fitting.

- Route the brine valve tubing out of the brine tank and connect to the nozzle assembly. Use the small screen and compression nut included (on skin-pack) to fasten.
- Connect the power cable to the transformer and plug into a 120V - 60Hz electrical outlet.

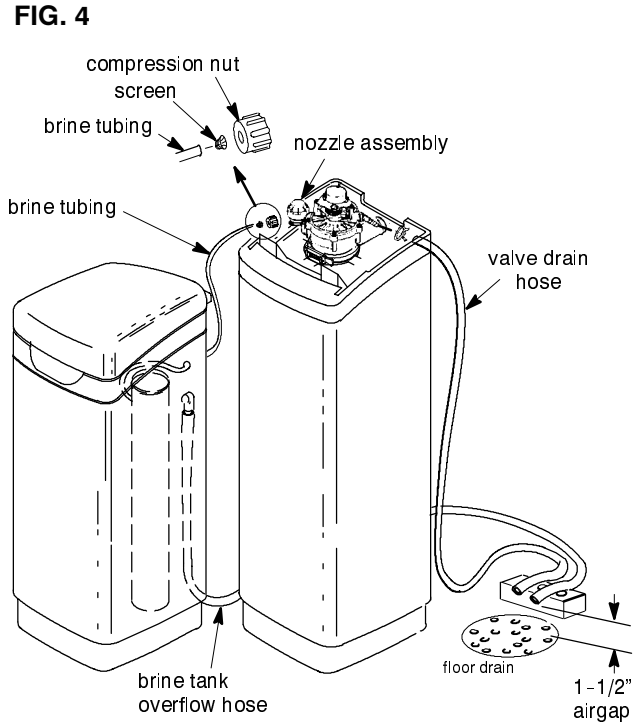

- Open nearby faucets and advance (use RCHG keypad) the softener valve to backwash position to vent air from the tank.** Turn on the water supply and allow the softener to fill. When water at nearby faucets runs smooth, with no more air bubbles, close the faucets and advance the softener valve to "service".
- Check your installation work for leaks.
- Make all timer settings, page 5.
- Sanitize the unit following procedures below, and use "Recharge Now" to start a recharge.
- Fill the brine tank with salt. You may use most water conditioner salts, but it must be clean. Recommended nugget, pellet or course solar salts have less than 1% impurities.
- Install the brine tank cover.

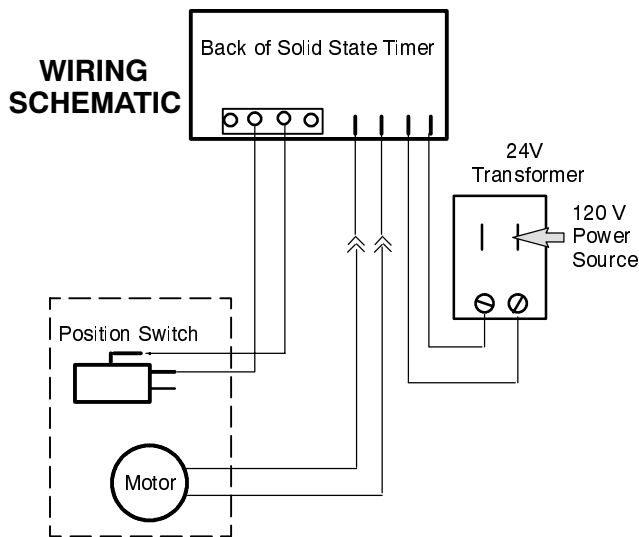

DISINFECTING THE SOFTENER

Care is taken at the factory to keep your softener clean and sanitary. Materials used to make the unit will not infect or contaminate your water supply, and will not cause bacteria to form or grow. However, during shipping, storage, installing and operating, bacteria could get into the unit. For this reason, sanitizing as follows is suggested when installing.

- Use a pail or hose to fill the brine tank with about 3 gallons of water.
- Remove the brinewell cover and pour about 1-1/2 oz. (2 to 3 tablespoons) of common household bleach into the softener brinewell. Clorox, Linco, BoPeep, White Sail, Eagle, etc. are brand names of bleach readily available. **Replace the brinewell cover.**
- Start an automatic regeneration to draw the bleach into and through the softener, and to the drain.

NOTE: When the sanitizing regeneration is over, all remaining bleach is flushed from the system.

SETTING THE TIMER

FIG. 5

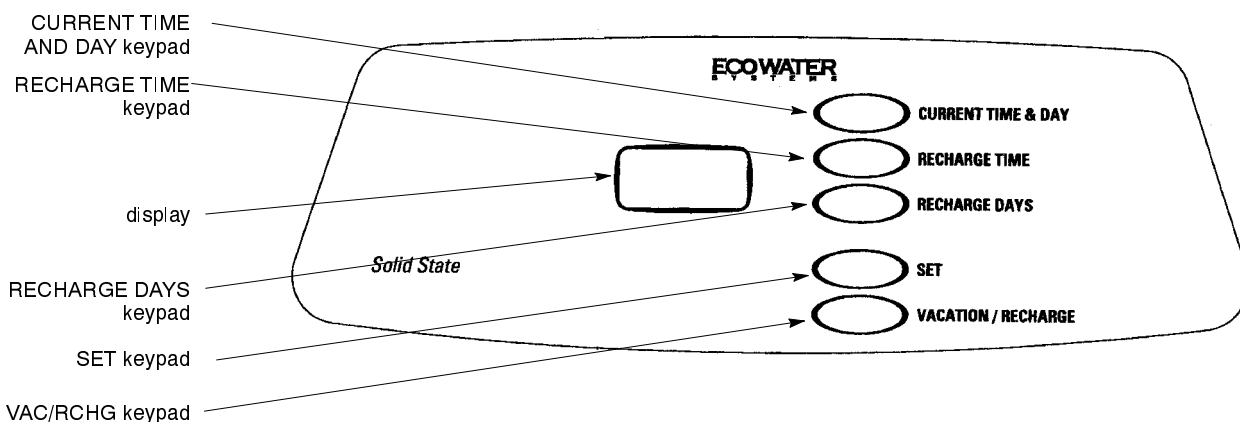

TIMER SETTINGS REQUIRED...upon installation, and after an extended power outage (see Power Outage Memory, page 1).

Note: When the transformer is plugged into the electrical outlet (step 9, page 4), **12:00AM, SU**nday begins to flash in the display area.

► **SET TIME OF DAY, AND PRESENT DAY OF WEEK**

1. Press the CURRENT TIME AND DAY keypad. The hour display continues to flash.

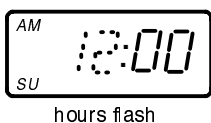

2. Press the SET keypad until the present hour of the day shows. Be sure AM for morning hours, or PM for afternoon and evening hours shows.

3. Press the CURRENT TIME AND DAY keypad to steady the hour display. Minutes begin to flash.

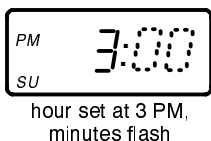

4. Press the SET keypad until the present minutes show.

5. Press the CURRENT TIME AND DAY keypad again to steady the time. A day of the week begins to flash.

gins to flash in the display area. Program the timer as follows.

Note: When setting the timer, press the keypad repeatedly to move the display 1 hour, minute, day etc. at a time. Hold the button in for fast advance.

6. Press the SET keypad until the present day of the week shows.

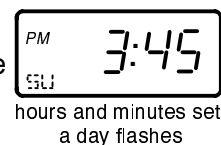

7. Press the CURRENT TIME AND DAY keypad again to steady the entire display.

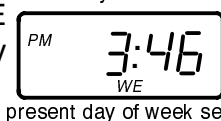

NOTE: The timer has factory set default values that automatically apply when the timer is plugged into electrical power. These values include 3 set regenerations, or recharges, each week (on Mondays, Wednesdays and Saturdays), with a 2:00 AM starting time. This schedule will provide most families with their soft water requirements, and no other timer settings are needed. However, if you want to adjust the unit to the most economical settings for your particular water supply and water usage, continue below.

► **REGENERATION (STARTING) TIME, AND/OR REGENERATION DAYS**

Note: Use the table on page 6 as a guide for setting days of regeneration.

1. Press the RECHARGE TIME keypad and the currently set regeneration starting time flashes. To change the regeneration start time, do step 2. Otherwise, go to step 3.

2. Press the SET keypad until the desired regeneration starting hour shows. Press the CURRENT TIME AND DAY keypad to return the present time,

or continue below to change days of regeneration.

3. Press the RECHARGE DAY keypad and **SU**nday begins to flash.

... If you want regenerations to occur on Sundays (see table), press the SET keypad until **On** shows.

... If you *do not* want Sunday regenerations, press the SET keypad until **OFF** shows.

SETTING THE TIMER

4. Press the RECHARGE DAY keypad again and **MO**nday flashes. As you did in step 3, use the SET keypad to set ON or OFF, as indicated in the table.

5. Press the RECHARGE DAY keypad to display a flashing TUesday, WEdnesday, etc., each time us-

ing the SET keypad to set ON or OFF, as the table shows.

6. After regeneration is either set or cancelled for Saturdays, press the CURRENT TIME AND DAY keypad to return the present time and day display.

► FILL CYCLE MINUTES (determines salt usage for each regeneration)

NOTE: The table below also shows the fill minutes to set.

1. Press and *hold* in the RECHARGE TIME keypad until **FILL** shows in the display. In a few seconds, the currently set fill

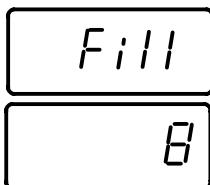

cycle minutes flash (factory setting is 8 minutes).

2. Press the SET keypad and set the needed minutes of fill, as the table shows.

3. Press the CURRENT TIME AND DAY keypad to return the present time and day display.

TABLE OF SUGGESTED REGENERATION SETTINGS

HOW TO USE THE TABLE

1. Locate the model in the left hand column. You will use this model section of the table only.
2. Locate the number of persons in the household, in the next column of the model section.
3. Locate the grains per gallon (gpg) hardness of the water supply, across the top of the table, in the model section.

4. Read across and down the table to find the intersecting point of steps 2 and 3.
5. At this intersecting point are the suggested days to regenerate the softener (M = Monday, T = Tuesday, etc.), and the minutes of FILL cycle to set.

EXAMPLE: ESS1000X R24 INSTALLED, 5 PEOPLE IN THE HOUSEHOLD, 18 GPG WATER HARDNESS: You would set the timer to regenerate 3 days each week (**Mondays, Wednesdays and Saturdays suggested**), using a 4 minute fill cycle time.

| MODEL | NO. OF PEOPLE | WATER HARDNESS, GRAINS PER GALLON (GPG) | | | | | | | | | | | | | |
|----------------------|---------------|---|------|--------|------|---------|------|----------|------|----------|------|---------------|------|---------------|------|
| | | 1 - 5 | | 6 - 10 | | 11 - 15 | | 16 - 20 | | 21 - 25 | | 26 - 35 | | 36 - 50 | |
| | | days | fill | days | fill | days | fill | days | fill | days | fill | days | fill | days | fill |
| ESS 1000X R24 | 1 - 2 | M | 3 | M | 3 | M | 3 | M | 4 | M | 5 | M Th | 4 | M Th | 5 |
| | 3 - 4 | M | 3 | M | 4 | M Th | 4 | M Th | 4 | M Th | 5 | M W S | 5 | M T Th S | 5 |
| | 5 - 6 | M | 3 | M Th | 3 | M Th | 4 | M W S | 4 | M W S | 5 | M T Th F S | 4 | ALL DAYS | 4 |
| | 7 - 8 | M | 4 | M Th | 4 | M W S | 3 | M T Th S | 4 | M T Th S | 5 | ALL DAYS | 4 | ALL DAYS | 7 |
| | | WATER HARDNESS, GRAINS PER GALLON (GPG) | | | | | | | | | | | | | |
| | | 1 - 5 | | 6 - 10 | | 11 - 15 | | 16 - 20 | | 21 - 35 | | 36 - 50 | | 51 - 65 | |
| | | days | fill | days | fill | days | fill | days | fill | days | fill | days | fill | days | fill |
| ESS 1000X R32 | 1 - 2 | M | 4 | M | 4 | M | 4 | M | 4 | M | 8 | M Th | 5 | M W S | 4 |
| | 3 - 4 | M | 4 | M | 4 | M | 6 | M Th | 4 | M W S | 5 | M W S | 7 | M T Th F S | 5 |
| | 5 - 6 | M | 4 | M | 6 | M Th | 5 | M Th | 6 | M T Th S | 5 | M T Th F S | 6 | M T Th F S Su | 7 |
| | 7 - 8 | M | 4 | M Th | 4 | M Th | 6 | M W S | 5 | ALL DAYS | 4 | M T Th F S Su | 7 | ALL DAYS | 9 |

Minutes of FILL

| | | | | | | | | | | | |
|----|-----|-----|-----|-----|-----|-----|-----|-----|----|-----|------|
| 1 | 2 | 3 | 4 | 5 | 6 | 7 | 8 | 9 | 10 | 11 | 12 |
| .9 | 1.8 | 2.7 | 3.6 | 4.5 | 5.4 | 6.3 | 7.2 | 8.1 | 9 | 9.9 | 10.8 |

Pounds of SALT

FEATURES

RECHARGE NOW

If you have used, or plan to use, more water than usual (house guests, extra washing, etc.), you could run out of soft water before the next scheduled regeneration occurs. To be assured this will not happen, press (bottom half only) the VAC/RCHG keypad and *hold* in until **RCHG** begins to flash in the time display. A regeneration begins immediately,

and it will last for about 2 hours. When over, you will have a full supply of soft water.

NOTE: Avoid using HOT water during the regeneration, because the water heater will refill with hard water.

VACATION CONTROL

Before going on vacation, or other long absence, **touch** (do not hold in) the bottom half of the VAC/RCHG keypad so VAC starts to flash in the display. The timer continues to keep time, but regenerations will not occur to waste water and salt.

When you return, touch the bottom half of the VAC/RCHG keypad again to return the softener to service, and the present time in the display. **REMEMBER TO DO THIS, or the softener will not regenerate, and you will soon have hard water.**

AUTOMATIC ELECTRONIC DIAGNOSTICS

The faceplate has a self-diagnostic function for the electrical system (except input power). The faceplate monitors electronic components and circuits for correct operation. If a malfunction occurs, an error code appears in the faceplate display.

appear, and the possible defects for each code.

While an error code appears in the display, all faceplate keypads are inoperable except the SET keypad. SET remains operational so the service person can make the *Manual Advance Diagnostics* to further isolate the defect.

The chart below shows the error codes that could

POSSIBLE DEFECT

| CODE | MOST LIKELY >-----> | LEAST LIKELY |
|--------------------------------|---|--------------|
| Err 01 Err 02 Err 03 Err 04 | wiring harness or connection to position switch / switch / valve defect causing high torque / motor inoperative | |
| Err 05 | faceplate | |

PROCEDURE FOR REMOVING ERROR CODE FROM FACEPLATE: 1. Unplug transformer---- 2. Correct defect---- 3. Plug in transformer---- 4. Wait for 6 minutes. The error code will return if the defect was not corrected. Press and hold the VAC/RCHG keypad for 3 seconds as an alternate way to clear an error code.

REPAIR PARTS

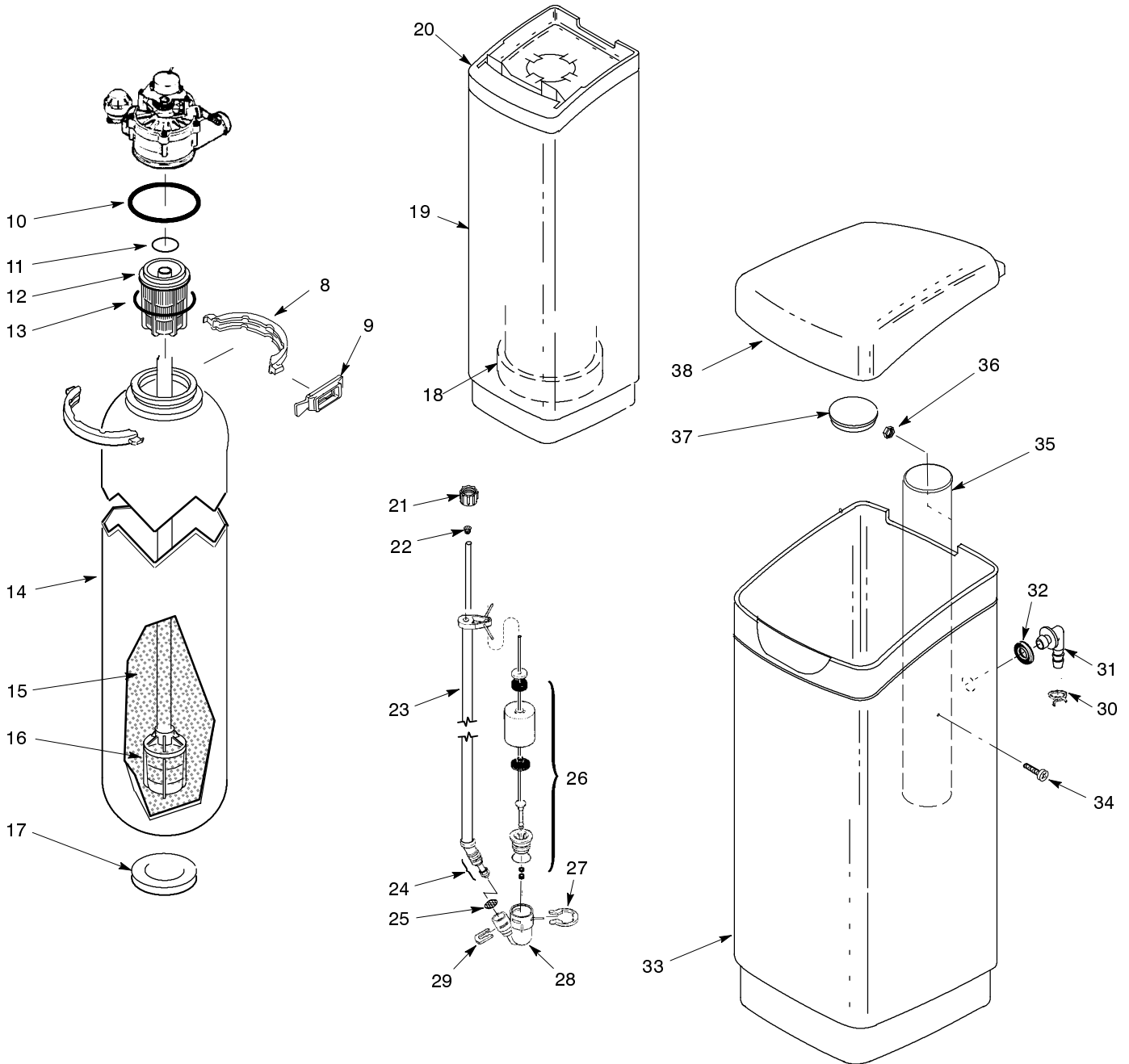
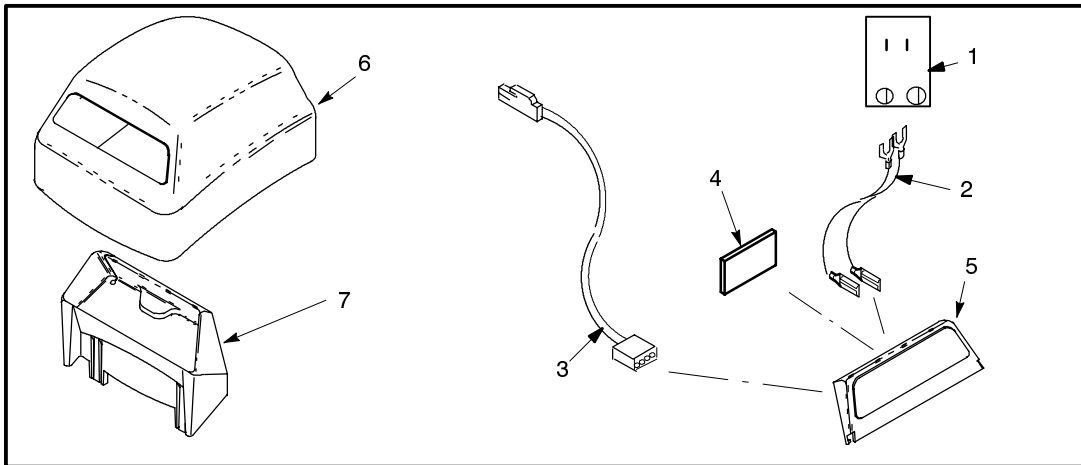

REPAIR PARTS

| KEY NO. | PART NUMBER | PART DESCRIPTION |
|---------|-------------|----------------------------------|
| 1 | 7095373 | Transformer, 24V - 10VA |
| 2 | 7132840 | Power Cable |
| 3 | 7130767 | Wire Harness (switch) |
| 4 | 7218701 | Repl PWA |
| 5 | 7210517 | Faceplate, order following decal |
| - | 7214197 | Decal, Faceplate |
| 6 | 7210478 | Top Cover |
| 7 | 7211173 | Faceplate Support |
| 8 | 7176292 | Clamp Section, 2 req. |
| 9 | 7088033 | Clamp Retainer, 2 req |
| 10 | 7170296 | O-ring Seal, 2-7/8" x 3-1/4" |
| 11 | 7170254 | O-ring, 13/16" x 1-1/16" |
| 12 | 7077870 | Top Distributor |
| 13 | 7170270 | O-ring, 2-3/4" x 3" |
| 14 | 7113058 | Resin Tank, 8" dia. x 40" (R24) |
| - | 7092202 | Resin Tank, 10" dia. x 47" (R32) |
| 15 | 0502272 | Resin, 1 cu ft ☐ |
| - | 0501741 | Resin, 1/2 cu ft ☐ |
| 16 | 7105047 | Repl. Distributor |
| 17 | 1184700 | Spacer (R24 only) |
| 18 | 7141205 | Tank Support |
| 19 | 7218620 | Sleeve (R24) |
| - | 7218646 | Sleeve (R32) |

☐ R24 uses 3/4 cu ft (40 lbs), R32 uses 1 cu ft

| KEY NO. | PART NUMBER | PART DESCRIPTION |
|---------|-------------|---|
| 20 | 7210460 | Rim |
| 21 | 1202600 | Nut-Ferrule |
| 22 | 7171349 | Screen |
| 23 | 7113016 | Tubing Assembly, B.V. |
| 24 | 7095470 | Brine Tube |
| 25 | 7131365 | Screen |
| 26 | 7113008 | Float, Stem & Guide |
| 27 | 1205500 | Clip |
| 28 | 7092252 | Brine Valve Body |
| 29 | 7080653 | Clip |
| ■ | 7116488 | Brine Valve Assembly (includes 23 - 29) |
| 30 | 0900431 | Hose Clamp |
| 31 | 1103200 | Hose Adaptor |
| 32 | 9003500 | Grommet |
| 33 | 7218612 | Brine Tank |
| 34 | 7219587 | Screw |
| 35 | 7109871 | Brinewell |
| 36 | 7219595 | Washer |
| 37 | 7155115 | Brinewell Cover |
| 38 | 7210486 | Brine Tank Cover |

REPAIR PARTS

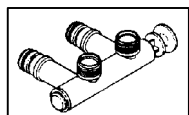
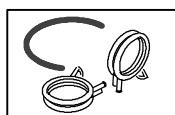
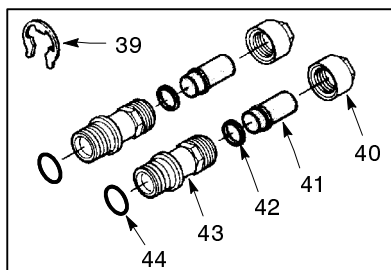
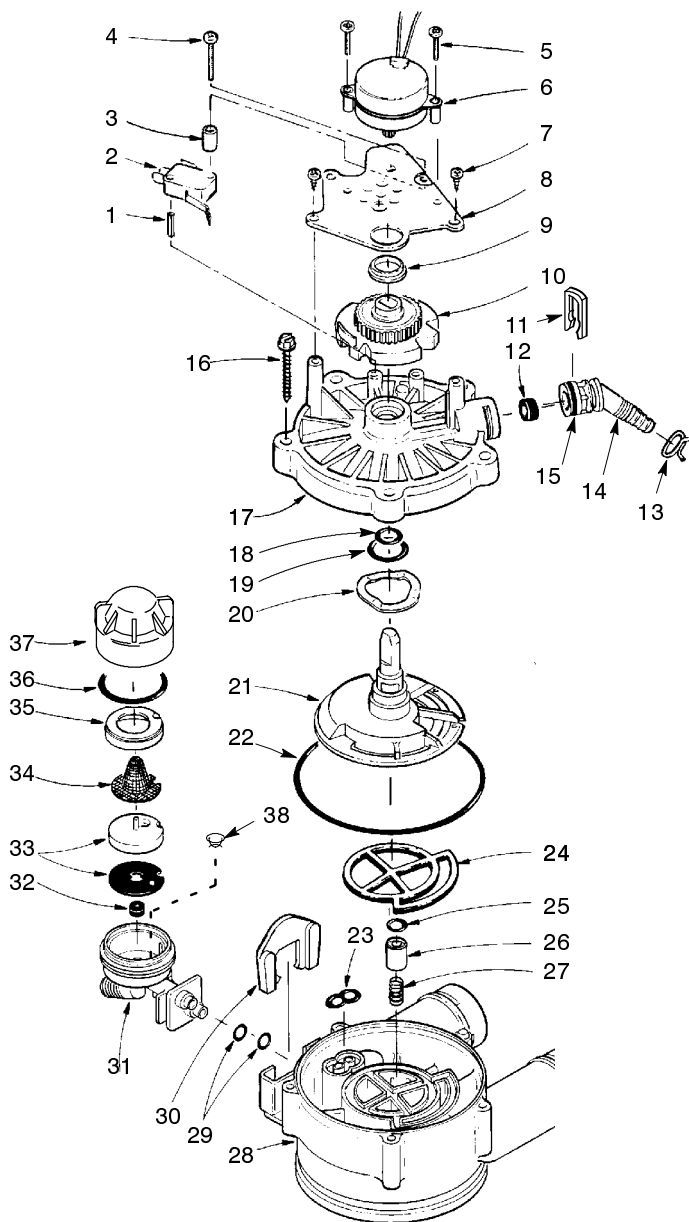

| KEY NO. | PART NUMBER | PART DESCRIPTION |
|---------|-------------|--|
| 1 | 7077472 | Expansion Pin |
| 2 | 7030713 | Switch |
| 3 | 7117816 | Spacer |
| 4 | 7070412 | Screw, #4-24 x 1-1/8" |
| 5 | 7131755 | Screw, #6-20 x 7/8" (2) |
| 6 | 7218793 | Motor |
| 7 | 0900857 | Screw, #6-20 x 3/8" (2) |
| 8 | 7117808 | Motor Plate |
| 9 | 0503288 | Bearing |
| 10 | 7113927 | Cam and Gear |
| 11 | 7142942 | Clip (drain) |
| 12 | 0501228 | Flow Plug, #18 (R24) |
| - | 7092618 | Flow Plug, 2.0 (R32) |
| 13 | 0900431 | Hose Clamp |
| 14 | 7024160 | Drain Hose Adaptor |
| 15 | 7170327 | O-ring, 5/8" x 13/16" |
| 16 | 7074123 | Screw, #10-14 x 2 (5) |
| 17 | 7085263 | Valve Cover |
| 18 | 7170238 | O-ring, 7/16" x 5/8" |
| 19 | 7170212 | O-ring, 3/4" x 15/16" |
| 20 | 7082087 | Wave Washer |
| 21 | 7199232 | Rotor & Disc |
| 22 | 7170246 | O-ring, 3-3/8" x 3-5/8" |
| 23 | 7081764 | Seal (nozzle & venturi) |
| 24 | 7134224 | Rotor Seal |
| 25 | 7170204 | O-ring, 3/8" x 9/16" |
| 26 | 7092642 | Plug (drain seal) |
| 27 | 7129889 | Spring |
| 28 | 7082053 | Valve Body |
| 29 | 7170319 | O-ring, 1/4" x 3/8" (2) |
| 30 | 7081201 | Retainer (nozzle & venturi) |
| 31 | 7081104 | Nozzle & Venturi Housing |
| 32 | 1148800 | Flow Plug, .3 gpm |
| 33 | 7113024 | Nozzle & Venturi -Gasket Kit (R24) |
| - | 7113032 | Nozzle & Venturi -Gasket Kit (R32) |
| - | 7204362 | Gasket (only) |
| 34 | 7146043 | Screen |
| 35 | 7167659 | Screen Support |
| 36 | 7170262 | O-ring, 1-3/16" x 1-3/8" |
| 37 | 7199729 | Cap |
| 38 | 7095030 | Cone Screen |
| 39 | 7116713 | Clip (2) |
| 40 | 0507369 | Installation Nut (2) |
| 41 | 0507615 | Installation Tube (2) |
| 42 | 7170335 | Washer (2) |
| 43 | 2207800 | Installation Adaptor (2) - includes key no. 44 |
| 44 | 7170288 | O-ring, 15/16" x 1-3/16" (2) |
| 45 | 7207718 | Hose Clamp (2) |
| - | 7207726 | Ground Wire |
| 46 | 7129871 | Bypass Valve (optional - not included) |
| ■ | 7085221 | Nozzle & Venturi Assem. (R24) |
| | 7091866 | Nozzle & Venturi Assem. (R32) |
| ■ | 7129716 | Seal Kit (incl. key nos. 18, 19, 22 - 25) |
| ■ | 7125982 | Repl. Valve (includes key nos. 16 - 28) |